

Extraction fan

**FUA-1800 | 2100 | 3000 | 4700**



EN

Installation and user manual

---

---

## TABLE OF CONTENTS

|                             |   |
|-----------------------------|---|
| PREFACE.....                | 2 |
| 1 INTRODUCTION.....         | 2 |
| 2 PRODUCT DESCRIPTION ..... | 3 |
| 3 SAFETY INSTRUCTIONS ..... | 4 |
| 4 INSTALLATION .....        | 5 |
| 5 USE .....                 | 7 |
| 6 MAINTENANCE .....         | 7 |
| 7 TROUBLESHOOTING .....     | 7 |
| 8 SPARE PARTS .....         | 8 |
| 9 ELECTRICAL DIAGRAM .....  | 8 |
| 10 DISPOSAL.....            | 8 |
| DECLARATIONS.....           | 8 |

### EN | ORIGINAL INSTRUCTION

All rights reserved. The information given in this document has been collected for the general convenience of our clients. It has been based on general data pertaining to construction material properties and working methods known to us at the time of issue of the document and is therefore subject at any time to change or amendment and the right to change or amend is hereby expressly reserved. The instructions in this publication only serve as a guideline for installation, use, maintenance and repair of the product mentioned on the cover page of this document. This publication is to be used for the standard model of the product of the type given on the cover page. Thus the manufacturer cannot be held responsible for any damage resulting from the application of this publication to the version actually delivered to you. This publication has been written with great care. However, the manufacturer cannot be held responsible, either for any errors occurring in this publication or for their consequences.

*To improve comprehension for people whose first language is not English, we have written parts of this manual in Simplified Technical English (STE). STE is a controlled language originally developed for aerospace industry maintenance manuals. It offers a carefully limited and standardized subset of English, along with specific writing rules.*







## PREFACE

### Using this manual

This manual is intended to be used as a work of reference for professional, well trained and authorised users to be able to safely install, use, maintain and repair the product mentioned on the cover of this document.

### Pictograms and symbols

The following pictograms and symbols are used in this manual:

|  |   |
|--|---|
|    | <b>TIP</b><br>Suggestions and recommendations to simplify carrying out tasks and actions.   |
|    | <b>ATTENTION</b><br>A remark with additional information for the user. A remark brings possible problems to the user's attention.   |
|    | <b>WARNING!</b><br>Procedures which, if not carried out with the necessary caution, may damage the product or cause serious personal injury.  |
|    | <b>CAUTION!</b><br>Denotes risk of electric shock.  |
|    | <b>WARNING!</b><br>Fire hazard! Important warning to prevent fire.  |
|   | <b>Personal protective equipment (PPE)</b><br>Instruction to use respiratory protection when you do service, maintenance and repair jobs, as well as during functional testing. We recommend to use a half-face respirator according to EN 149:2001 + A1:2009, class FFP3 (Directive 89/686/EEC). |
|  | <b>Personal protective equipment (PPE)</b><br>Instruction to use protective gloves when you do service, maintenance and repair jobs.  |

### Text indicators

Listings indicated by "-" (hyphen) concern enumerations. Listings indicated by "•" (bullet point) describe steps to perform.

### Service and technical support

For information about specific adjustments, maintenance or repair jobs which are not dealt with in this manual, please contact the supplier of the product. He will always be willing to help you. Make sure you have the following specifications at hand:

- product name
- serial number

You can find these data on the identification plate.

## 1 INTRODUCTION

### 1.1 Identification of the product

The identification plate contains, among other things, the following data:

- product name
- serial number
- supply voltage and frequency
- power consumption

### 1.2 General description

The FUA is an extraction fan that is especially designed to remove welding fumes and other harmful substances such as dust, oil mist and exhaust gases.

The different fan types are intended and designed for use with extraction arms, filter units and vehicle exhaust extraction systems.

### 1.3 Product combinations

You can use the FUA fans in a variety of welding fume extraction and vehicle exhaust systems of Plymovent.



The table below shows which type of additional mounting bracket you need in a specific configuration.

| Fan type   | Application  | Mounting bracket  |
|--|--|---|
| <b>General</b>                                     |  |   |
| FUA-1800<br>FUA-2100                               | + (Free-)standing, wall or ceiling mounting (universal)  | ▶ MB-FUA/S1   |
| FUA-3000<br>FUA-4700                               | + (Free-)standing, wall or ceiling mounting (universal)  | ▶ MB-FUA/S2   |
| <b>Extraction arm/crane</b>                        |  |   |
| FUA-1800<br>FUA-2100                               | + KUA-160<br>KUA-200<br>Junior LM-2<br>EconomyArm  | <i>No bracket required (direct mounting on arm bracket)</i> |
| FUA-1800<br>FUA-2100                               | + MultiSmart Arm-125<br>MultiSmart Arm-160<br>MultiSmart Arm-200<br>FlexMax<br>UK "Plymoth"<br>FEB crane (vehicle exhaust)<br>EB crane (vehicle exhaust) | ▶ MB-FUA/C1   |
| FUA-3000   | + MSA-200<br>FlexMax<br>UK "Plymoth"<br>FEB crane<br>EB crane  | ▶ MB-FUA/C2   |
| FUA-3000   | + KUA-200<br>MultiSmart Arm-200  | ▶ MB-FUA/C2   |
| <b>Duct connection / central extraction system</b> |  |   |
| FUA-1800<br>FUA-2100                               | + Duct connection  | ▶ MB-FUA/S1   |
| FUA-3000<br>FUA-4700                               | + Duct connection  | ▶ MB-FUA/S2   |
| <b>Exhaust extraction systems</b>                  |  |   |
| FUA-1800<br>FUA-2100                               | + Hose reel / drop system (vehicle exhaust)  | ▶ FEF-KIT   |

### 1.4 Options and accessories

The following products can be obtained as an option and/or accessory:

| Fan type   | Option type                |
|--|----------------------------|
| <b>Filter-fan adapter</b>                          |                            |
| FUA-2100:  | FF-FAN/S                   |
| FUA-3000:  | FF-FAN/B                   |
| FUA-4700:  |                            |
| <b>Outlet transition from rectangular to round</b> |                            |
| FUA-3000:  | OL-250/FUA-3000 (Ø 250 mm) |
| FUA-4700:  | OL-250/FUA-4700 (Ø 250 mm) |
|  | OL-315/FUA-4700 (Ø 315 mm) |

|   |                                |
|---|--------------------------------|
| Soft connection piece for noise and vibration free connection to duct |                                |
| FUA-1800:   | SC-160 (inlet/outlet Ø 160 mm) |
| FUA-2100:   |                                |
| FUA-3000:   | SC-250 (inlet/outlet Ø 250 mm) |
| FUA-4700:   |                                |
| FUA-4700:   | SC-315 (outlet Ø 315 mm)       |

## 1.5 Technical specifications



|   |  |           |
|---|--|-----------|
| Motor design  | IE2                                      |           |
| Speed of revolutions                                | 2800 rpm                                 |           |
| Insulation class                                    | F  |           |
| Protection class                                    | IP 55                                    |           |
| Max. start/stops per hour                           | 30                                       |           |
| Max. airflow temperature                            | 80°C                                     |           |
| Noise level according to ISO 3746 (duct connected): |  |           |
| - FUA-1800  | 64 dB(A)                                 |           |
| - FUA-2100  | 66 dB(A)                                 |           |
| - FUA-3000  | 68 dB(A)                                 |           |
| - FUA-4700  | 66 dB(A)                                 |           |
| Available connection voltages:                      | <i>(all fans run on 50 Hz frequency)</i> |           |
| - FUA-1800  | 230-400V/3ph                             |           |
| - FUA-2100  | 230V/1ph   230-400V/3ph                  |           |
| - FUA-3000  | 230-400V/3ph                             |           |
| - FUA-4700  | 230-400V/3ph                             |           |
| Power consumption:                                  |  |           |
| - FUA-1800  | 0,55 kW                                  |           |
| - FUA-2100  | 0,75 kW                                  |           |
| - FUA-3000  | 1,1 kW                                   |           |
| - FUA-4700  | 2,2 kW                                   |           |
| Nominal current:                                    | 1ph:                                     | 3ph:      |
| - FUA-1800  |  | 1,4-1,5 A |
| - FUA-2100  | 5 A                                      | 1,9-2 A   |
| - FUA-3000  |  | 2,5-2,7 A |
| - FUA-4700  |  | 4,8-4,9 A |



Refer to the available product data sheets for detailed product specifications.

## 1.6 Dimensions

Refer to Fig. I on page 9.



## 1.7 Pressure drop

Refer to Fig. II on page 10.

## 1.8 Ambient conditions

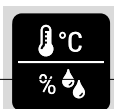

|                            |      |
|----------------------------|------|
| Min. operating temperature | 5°C  |
| Nom. operating temperature | 20°C |
| Max. operating temperature | 80°C |
| Max. relative humidity     | 80%  |

Fig. 2.1 & Fig. 2.2

- A Outlet
- B Motor
- C Housing
- D Inlet
- E Fan wheel

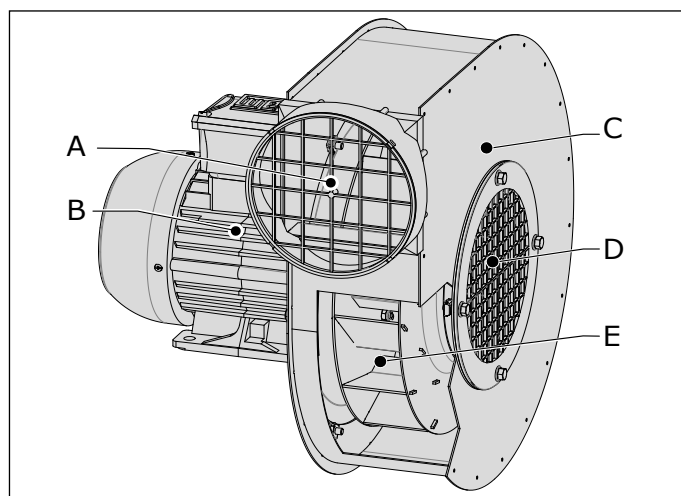

Fig. 2.1 Main components FUA-1800/2100

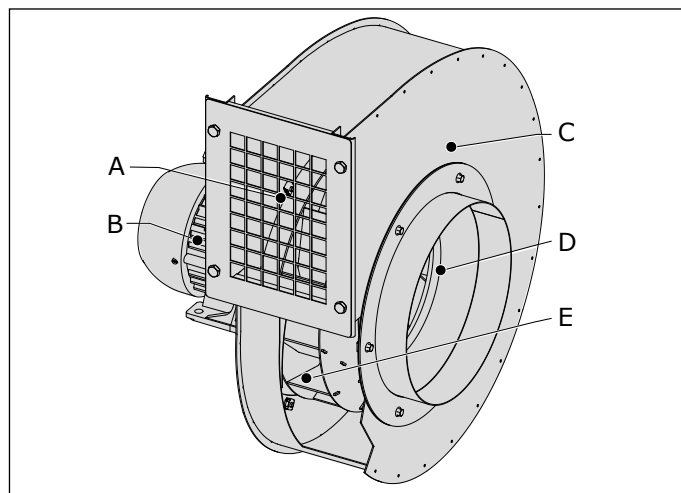

Fig. 2.2 Main components FUA-3000/4700

## 2.2 Operation



The FUA fans have been designed for extracting welding fumes, oil mist and vehicle exhaust gases in an extraction system.

The air is extracted through the inlet and exhausted via the outlet.

The fans are suitable for connection to:

- one or more<sup>1</sup> extraction arms or cranes
- a filter system
- a vehicle exhaust system

### 2.2.1 Control equipment

Plymovent provides various control equipment to control the fan. Refer to the manual of the selected control equipment.

1. Depending on the specific type and configuration

## 2 PRODUCT DESCRIPTION

### 2.1 Components

The product consists of the following main components:

### 3 SAFETY INSTRUCTIONS

#### General

The manufacturer does not accept any liability for damage to the product or personal injury caused by ignoring of the safety instructions in this manual, or by negligence during installation, use, maintenance, and repair of the product mentioned on the cover of this document and any corresponding accessories.

Specific working conditions or used accessories may require additional safety instructions. Immediately contact your supplier if you detect a potential danger when using the product.



**The user of the product is always fully responsible for observing the local safety instructions and regulations. Observe all applicable safety instructions and regulations.**

#### User manual

- Everyone working on or with the product, must be familiar with the contents of this manual and must strictly observe the instructions therein. The management should instruct the personnel in accordance with the manual and observe all instructions and directions given.
- Do not change the order of the steps to perform.
- Keep the manual with the product.

#### Users

The use of this product is exclusively reserved to authorised, trained and qualified users. Temporary personnel and personnel in training can only use the product under supervision and responsibility of skilled engineers.

#### Intended use<sup>2</sup>

The product has been designed exclusively for extracting gases and particles which are released during the most common welding processes and for extracting vehicle exhaust gases. Using the product for other purposes is considered contrary to its intended use. The manufacturer accepts no liability for any damage or injury resulting from such use. The product has been built in accordance with state-of-the-art standards and recognised safety regulations. Only use this product when in technically perfect condition in accordance with its intended use and the instructions explained in the user manual.

#### Technical specifications

Do not change the specifications given in this manual.

#### Modifications

Modification of (parts of) the product is not allowed.



#### Installation

- The installation of this product is exclusively reserved to authorised, trained and qualified engineers.
- The electric connection must be executed in accordance with the local codes and requirements. Ensure compliance with the EMC regulatory arrangements.
- During installation, always use Personal Protective Equipment (PPE) to avoid injury. This also applies to persons who enter the work area during installation.
- Use sufficient climbing gear and safety guards when working on a higher level than 2 metres (local restrictions may apply).

2. "Intended use" as explained in EN-ISO 12100-1 is the use for which the technical product is suited as specified by the manufacturer, inclusive of his directions in the sales brochure. In case of doubt it is the use which can be deduced from the construction, the model and the function of the technical product which is considered normal use. Operating the machine within the limits of its intended use also involves observing the instructions in the user manual.

- Do not install the product in front of entrances and exits that must be used for emergency services.
- Mind any gas and water pipes and electric cables.
- Make sure that the workspace is well illuminated.
- Stay alert and keep your attention to your work. Do not install the product when you are under the influence of drugs, alcohol or medicine.
- Air containing particles such as chromium, nickel, beryllium, cadmium, lead etc., should never be recycled. This air must always be brought outside the working area.

#### Use

|   |  |
|---|--|
|    | <b>WARNING!</b><br>Fire hazard! Do <b>not</b> use the product for: <ul style="list-style-type: none"><li>- polishing applications in combination with grinding, welding or any other application that generate sparks (fibers from polishing or abrasive flap disks are highly flammable and pose a high risk of filter fires when exposed to sparks)</li><li>- arc-air gouging</li><li>- extracting flammable, glowing or burning particles or solids or liquids</li><li>- extracting of aggressive fumes (such as hydrochloric acid) or sharp particles</li><li>- extracting dust particles that are released when welding surfaces treated with primer</li><li>- sucking cigarettes, cigars, oiled tissues, and other burning particles, objects, and acids</li></ul> |
|   | <b>WARNING!</b><br>Explosion hazard! Do <b>not</b> use the product for explosion-hazardous applications, e.g.: <ul style="list-style-type: none"><li>- aluminium laser cutting</li><li>- grinding aluminium and magnesium</li><li>- explosive environments or explosive substances/gases</li></ul>   |
|  | <b>WARNING!</b><br>Do <b>not</b> use the product for: <ul style="list-style-type: none"><li>- extraction of hot gases (more than 70°C continuously)</li><li>- flame spraying</li><li>- oil mist</li><li>- heavy oil mist in welding fume</li><li>- extraction of cement, saw dust, wood dust etc.</li></ul>  |

- Inspect the product and check it for damage. Verify the functioning of the safety features.
- During use, always use Personal Protective Equipment (PPE) to avoid injury. This also applies for persons who enter the work area.
- Check the working environment. Do not allow unauthorised persons to enter the working environment.
- Protect the product against water and humidity.
- Make sure the room is always sufficiently ventilated; this applies especially to confined spaces.
- Make sure that the workshop, in the vicinity of the product, contains sufficient approved fire extinguishers (suitable for fire classes ABC).
- Do not leave any tools or other objects in or on the unit.

#### Service, maintenance and repairs

- Always use Personal Protective Equipment (PPE) to avoid injury. This also applies for persons who enter the work area.
- Do not leave any tools in or on the product.
- Use sufficient climbing gear and safety guards when working on a higher level than 2 metres (local restrictions may apply).

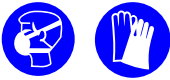
|  |   |
|--|---|
|  | <b>ATTENTION</b><br>Before you carry out service, maintenance and/or repair jobs:<br>- fully disconnect the fan from the mains  |
|  |  <b>Personal protective equipment (PPE)</b><br>Wear respiratory protection and protective gloves during service, maintenance and repairs. |

## 4 INSTALLATION

### 4.1 Tools and requirements

You need the following tools and requirements to install the fan:

- basic tools
- electrical tools



#### 4.1.1 To be sourced locally

If applicable:

- hardware to install the mounting bracket MB-FUA/S1 or MB-FUA/S2



### 4.2 Unpacking

Make sure that the product is complete. The package contains:

- extraction fan incl. inlet grid 3 mm
- connection flange with grid



#### 4.2.1 Mounting brackets

##### MB-FUA/S1 or MB-FUA/S2

- mounting bracket
- connection flange with grid (type S1 only)
- tube clamp (4)
- hardware

##### MB-FUA/CS or MB-FUA/C2

- mounting bracket
- connection flange (type C1 only)
- hardware

#### 4.2.2 Options and accessories

##### OL (outlet transition)

- outlet transition from rectangular to round

##### SC (soft connection)

- connection piece
- hose clamp (2)

### 4.3 Mounting

It depends on the specific configuration how you must install the fan. The table in paragraph 1.3 shows the various possibilities.



| To install the fan:                   | Proceed with paragraph:   |
|---------------------------------------|---|
| - on a MB-FUA/S1 or MB-FUA/S2         | 4.3.1   |
| - on a MB-FUA/C1 or MB-FUA/C2         | 4.3.2   |
| - directly on the arm bracket         | 4.3.4   |
| - type FUA-1800/2100 in a duct system | 4.3.5   |
| - type FUA-3000/4700 in a duct system | 4.3.5   |
| - on a FEF-KIT                        | <i>refer to the manual of the corresponding hose reel / drop system</i> |

#### 4.3.1 Fan on MB-FUA/S1 or MB-FUA/S2

To install the fan on the bracket, do the following.

Fig. 4.1

- If applicable: use the tube clamps (B) to install the bracket at the desired position<sup>3</sup>.
- Install the fan on the bracket with the supplied hardware.
- Tighten the bolts (A).

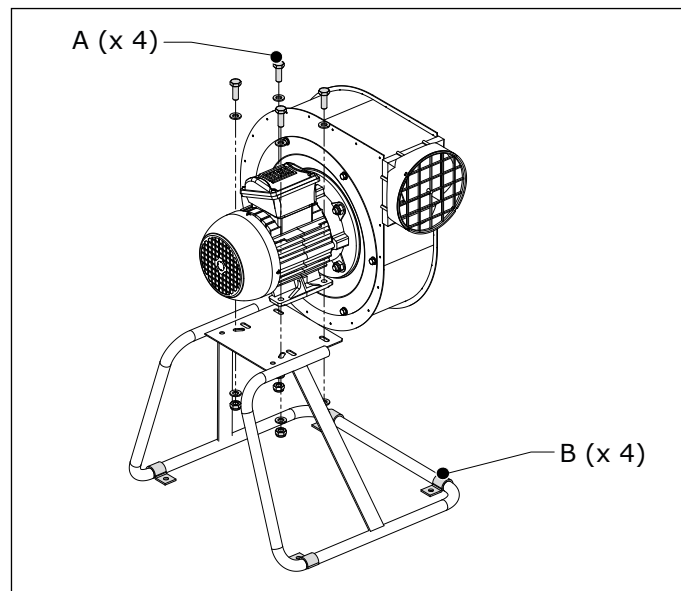



Fig. 4.1 Fan on mounting bracket MB-FUA/S1 or MB-FUA/S2

 This mounting bracket allows for installation upside down as well.

If you want to change the outlet position of the fan, proceed with paragraph 4.3.3.

#### 4.3.2 Fan on MB-FUA/C1 or MB-FUA/C2

To install the fan on the bracket, do the following.

Fig. 4.2

- Use the mounting holes (A) with suitable hardware<sup>4</sup> to install the bracket at the desired position on the wall.
- Install the fan on the bracket with the supplied hardware.
- Tighten the bolts (B).

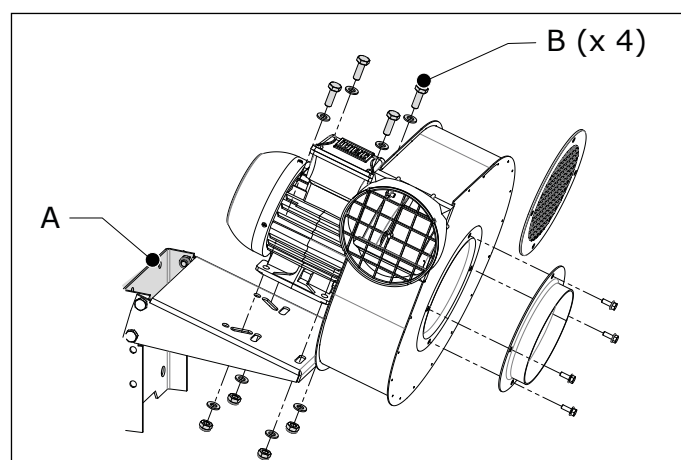

Fig. 4.2 Fan on mounting bracket MB-FUA/C1 or MB-FUA/C2

3. Hardware for mounting the tube clamps is not included; this depends on the wall, floor or ceiling type

4. Hardware not included; this depends on the wall type

### 4.3.3 Fan outlet position

If desired, you can change the outlet position of the fan. Refer to Fig. III on page 10 for the possible outlet directions.

To change the outlet position, do the following.

Fig. 4.3

- Determine the desired outlet position.
- If necessary: loosen the bolts (A) to disassemble the motor plate.
- Turn the motor in the desired position.
- Install the bolts again and tighten them securely.

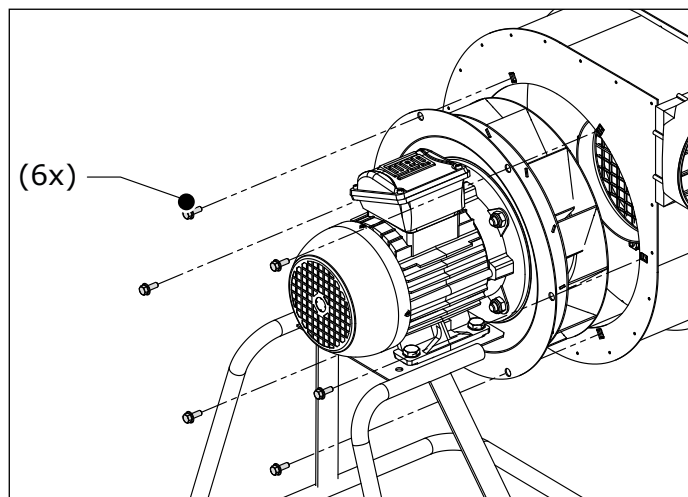

Fig. 4.3 Changing the outlet position

### 4.3.4 Fan directly on an extraction arm/crane

To install the fan on the arm bracket, do the following.

Fig. 4.4

- Loosen the bolts of the inlet grid (A).
- Put the fan, including inlet grid, on the arm bracket.
- Install the bolts (B) again and tighten them securely.

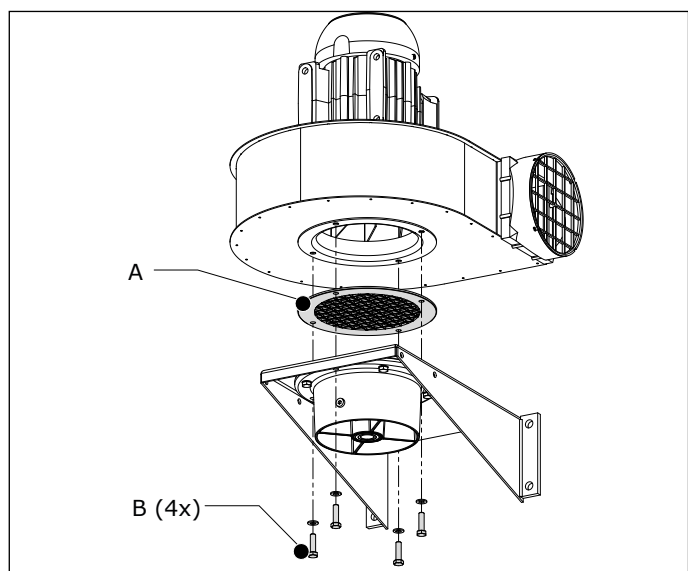

Fig. 4.4 Fan on arm bracket

### 4.3.5 Duct connection

We recommend to install a soft connection (refer to paragraph 1.4) between the inlet / outlet of the fan and the duct to reduce noise and vibrations of the fan and to avoid damage to the duct.

To install the soft connections, do the following.

#### FUA-1800/2100

Fig. 4.5

- Loosen the bolts of the inlet grid (A) and remove the grid.
- Install the connection flange with grid<sup>5</sup> (B) with the bolts of the inlet grid.
- Tighten the bolts.
- Slide the soft connections (C+F) on the inlet and outlet of the fan.
- Attach them with a hose clamp (D+E) on both sides.
- Tighten the hose clamps.



#### ATTENTION

In case the fan is not installed directly next to the filter system (if any), make sure that the extraction duct is sufficiently supported.

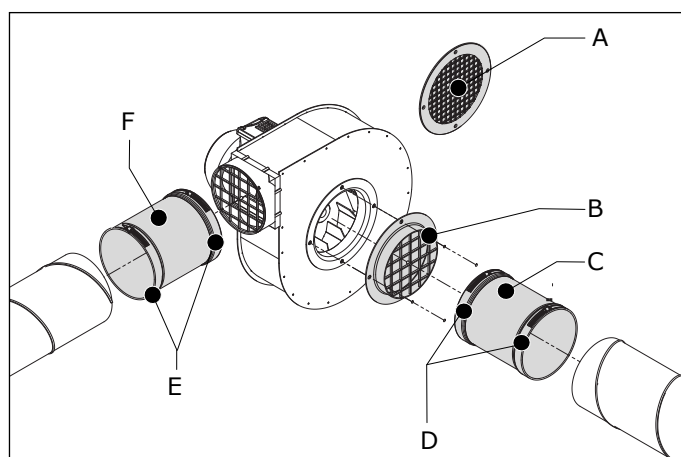

Fig. 4.5 Duct connection of the FUA-1800/2100

#### FUA-3000/4700

Fig. 4.6

- Loosen the bolts of the outlet grid (A) and remove the grid.
- Install the outlet transition (F) with the bolts of the outlet grid.
- Tighten the bolts.
- Slide a soft connection (B) on the inlet of the fan.
- Slide another soft connection (E) on the outlet transition (F).
- Attach the soft connections with hose clamps (C+D) on both sides.
- Tighten the hose clamps.

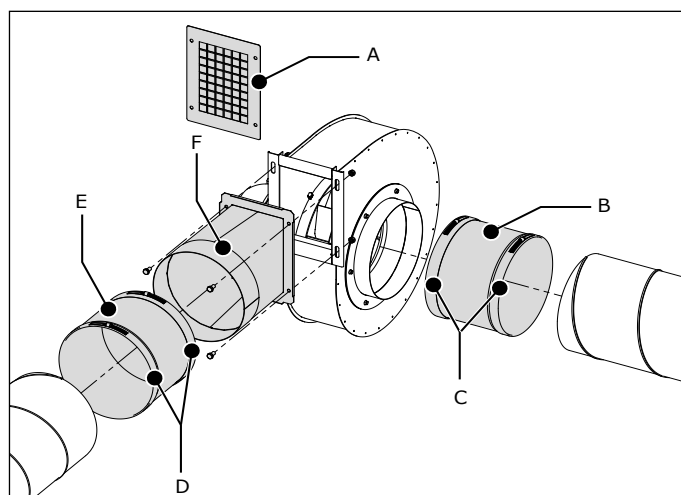

Fig. 4.6 Duct connection of the FUA-3000/4700

5. Supplied with the fan

## 4.4 Electric connection



### CAUTION!

Make sure that the fan is suitable for connection to the local mains. You can find information about the connection voltage and frequency on the identification plate.

The default setting of the 3-phase fans is 400V. If the mains voltage is 230V, you must change the wiring according to the instructions on the identification plate.

If necessary:

- Change the wiring from 400V to 230V.

### 4.4.1 Control equipment

There are various ways to control the fan.

To connect the control equipment, do the following.

- Connect the fan to the selected control equipment in accordance with the information on the identification plate on the motor.
- Connect the control equipment to the mains according to the separately supplied electrical diagram.

An arrow on the fan housing indicates the correct direction of rotation of the motor. The rotation is visible through the grid of the motor.

- Make sure that the direction of rotation of the motor is correct.
- If necessary, invert the connection of the phases.

## 5 USE

Refer to the documentation supplied with the selected control equipment how to control the fan.

## 6 MAINTENANCE

The fans require no specific maintenance.



## 7 TROUBLESHOOTING

If the fan does not function (correctly), consult the checklist below to see if you can remedy the error yourself. Should this not be possible, contact your supplier.



### WARNING

When you carry out the activities below:

- first de-energize the fan
- obey the safety regulations that are written in chapter 3

| Symptom   | Problem  | Possible cause  | Solution  |
|---|--|---|---|
| The motor does not start                        | The fan does not function                                | No mains voltage  | Connect the mains voltage   |
|   |  | The mains cord is defective                                 | Repair or replace the mains cord  |
|   |  | Loose contacts  | Repair the contacts   |
|   |  | Motor protection switch defective                           | Replace the motor protection switch   |
| The fan makes a humming sound, but does not run | Extraction capacity insufficient or no extraction at all | Motor defective   | Repair or replace the motor   |
|   |  | Motor uses 2 phases instead of 3                            | Repair the phase connection   |
| Motor stops automatically                       | The fan does not function                                | Motor capacitor defective or not connected (1ph motor only) | Connect or replace the motor capacitor  |
|   |  | Motor protection switch is activated                        | Let the fan cool down for some time. Make sure the setting of the motor protection switch is correct (refer to the electrical diagram). |
| Poor extraction capacity                        | The fan does not function properly                       | Motor defective   | Repair or replace the motor   |
|   |  | The fan is polluted   | Clean the fan blades  |
|   |  | Motor defective   | Repair or replace the motor   |
| Vibrations in the fan                           | Fan is not steady  | Imbalance in the fan  | Clean the fan blades  |
|   |  | Extraction of false air                                     | Replace the sealing material  |



## 8 SPARE PARTS

The following spare parts are available for the fan;



### FUA-1800 | FUA-2100

- refer to exploded view Fig. IV on page 11

### FUA-3000 | FUA-4700

- refer to exploded view Fig. V on page 12

## 9 ELECTRICAL DIAGRAM

Refer to the separately supplied electrical diagram.

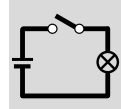

## 10 DISPOSAL

After the life of the product, dispose it of in accordance with federal, state or local regulations.



## DECLARATIONS

### CE declaration of conformity for machinery

We, Plymovent Manufacturing B.V., Koraalstraat 9, 1812 RK Alkmaar, Netherlands, herewith declare, on our own responsibility, that the products:

- FUA-1800
- FUA-2100
- FUA-3000
- FUA-4700

which this declaration refers to, are in accordance with the conditions of the following Directives:

- CE Machine Directive 2006/42/EC
- CE EMC 2014/30 EU
- CE LVD 2014/35 EU
- CE ErP Directive 2009/125 EC
- UKCA Supply of Machinery (Safety) Regulations 2008
- UKCA Electromagnetic Compatibility Regulations 2016
- UKCA The Electrical Equipment (Safety) Regulations 2016

Signature:

Name: M.S.J. Ligthart  
Position: Product Manager  
Date of issue: December 19<sup>th</sup>, 2022

*An **installation** is defined as a combination of several finished products or components that are assembled by an installer at a given place. The various parts of the installation are intended to operate together in a particular environment and to perform a specific task. The entire installation must comply with the relevant directives and standards. The assembly instructions given by the manufacturer, as well as the whole method of installation, must be in accordance with good engineering practices within the context of installations, as well as installation rules. Considering the above, the installer will be responsible for completing the installation and issuing the final CE Declaration of Conformity.*

Fig. I Dimensions

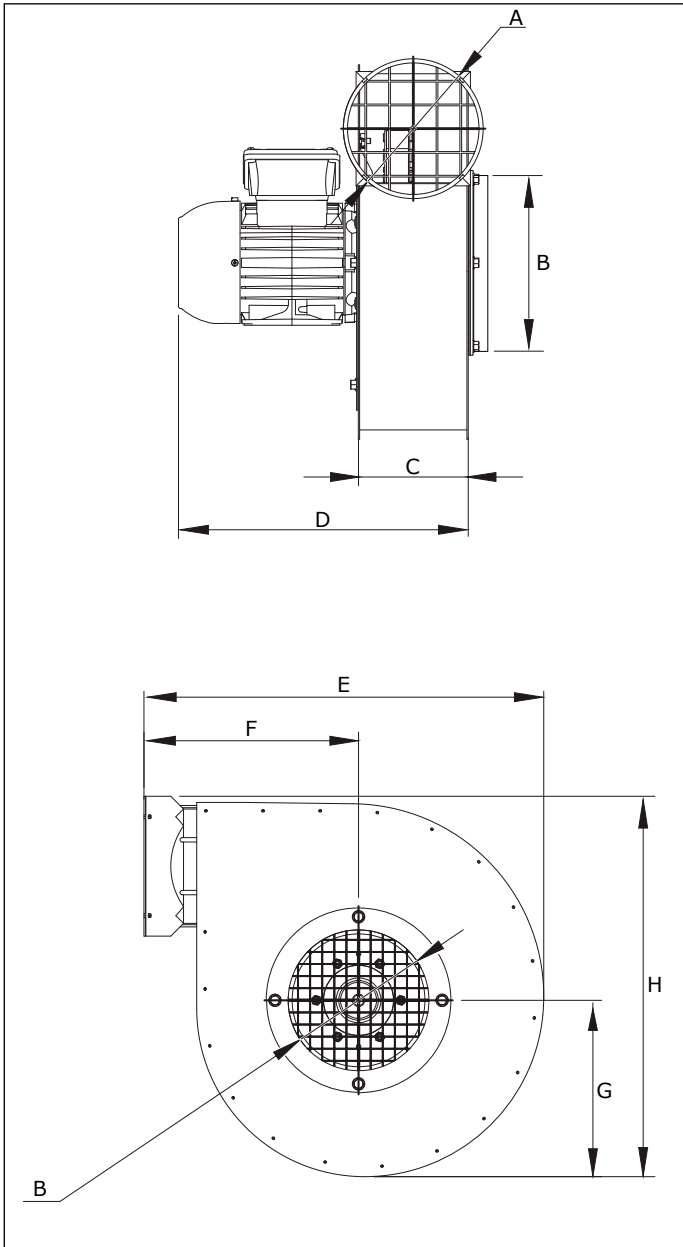

FUA-1800/2100

|   | FUA-1800 |       | FUA-2100 |       |
|---|----------|-------|----------|-------|
|   | mm       | inch  | mm       | inch  |
| A | Ø 160    | Ø 6.3 | Ø 160    | Ø 6.3 |
| B | Ø 160    | Ø 6.3 | Ø 160    | Ø 6.3 |
| C | 122      | 4.8   | 122      | 4.8   |
| D | 330      | 12.9  | 353      | 13.9  |
| E | 455 mm   | 17.9  | 455      | 17.9  |
| F | 244 mm   | 9.6   | 244      | 9.6   |
| G | Ø 160    | Ø 6.3 | Ø 160    | Ø 6.3 |
| H | 433      | 17    | 433 mm   | 17    |
| I | 201      | 7.9   | 201 mm   | 7.9   |

| Fan wheel: |       |        |       |        |
|------------|-------|--------|-------|--------|
| Diameter   | Ø 300 | Ø 11.8 | Ø 300 | Ø 11.8 |
| Width      | 25    | 1      | 60    | 2.4    |

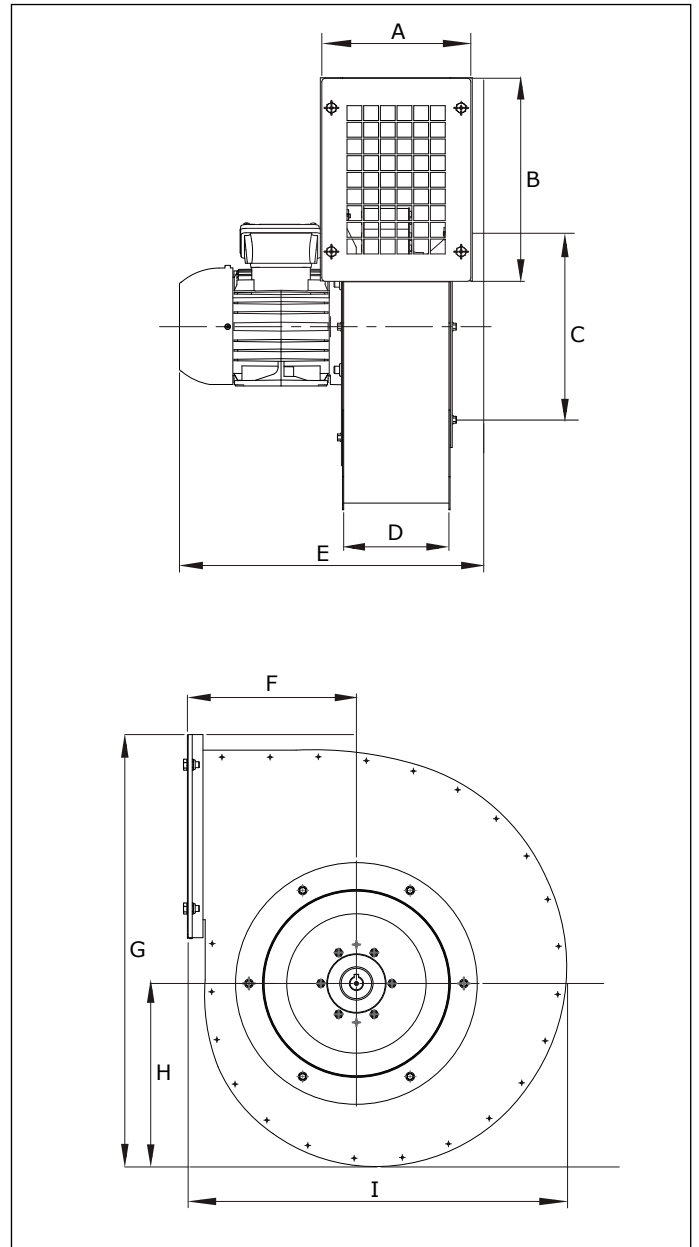

FUA-3000/4700

|   | FUA-3000 |       | FUA-4700 |       |
|---|----------|-------|----------|-------|
|   | mm       | inch  | mm       | inch  |
| A | 201      | 7.9   | 205      | 8.1   |
| B | 274      | 10.8  | 348      | 13.7  |
| C | Ø 250    | Ø 9.8 | Ø 245    | Ø 9.6 |
| D | 142      | 5.6   | 142      | 5.6   |
| E | 410      | 16.1  | 480      | 18.9  |
| F | 228      | 9     | 258      | 10.6  |
| G | 583      | 23    | 733      | 28.9  |
| H | 247      | 9.7   | 297      | 11.7  |
| I | 512      | 20.2  | 591      | 23.3  |

| Fan wheel: |       |        |       |      |
|------------|-------|--------|-------|------|
| Diameter   | Ø 320 | Ø 12.6 | Ø 380 | Ø 15 |
| Width      | 60    | 2.4    | 45    | 1.8  |

Fig. II Pressure drop

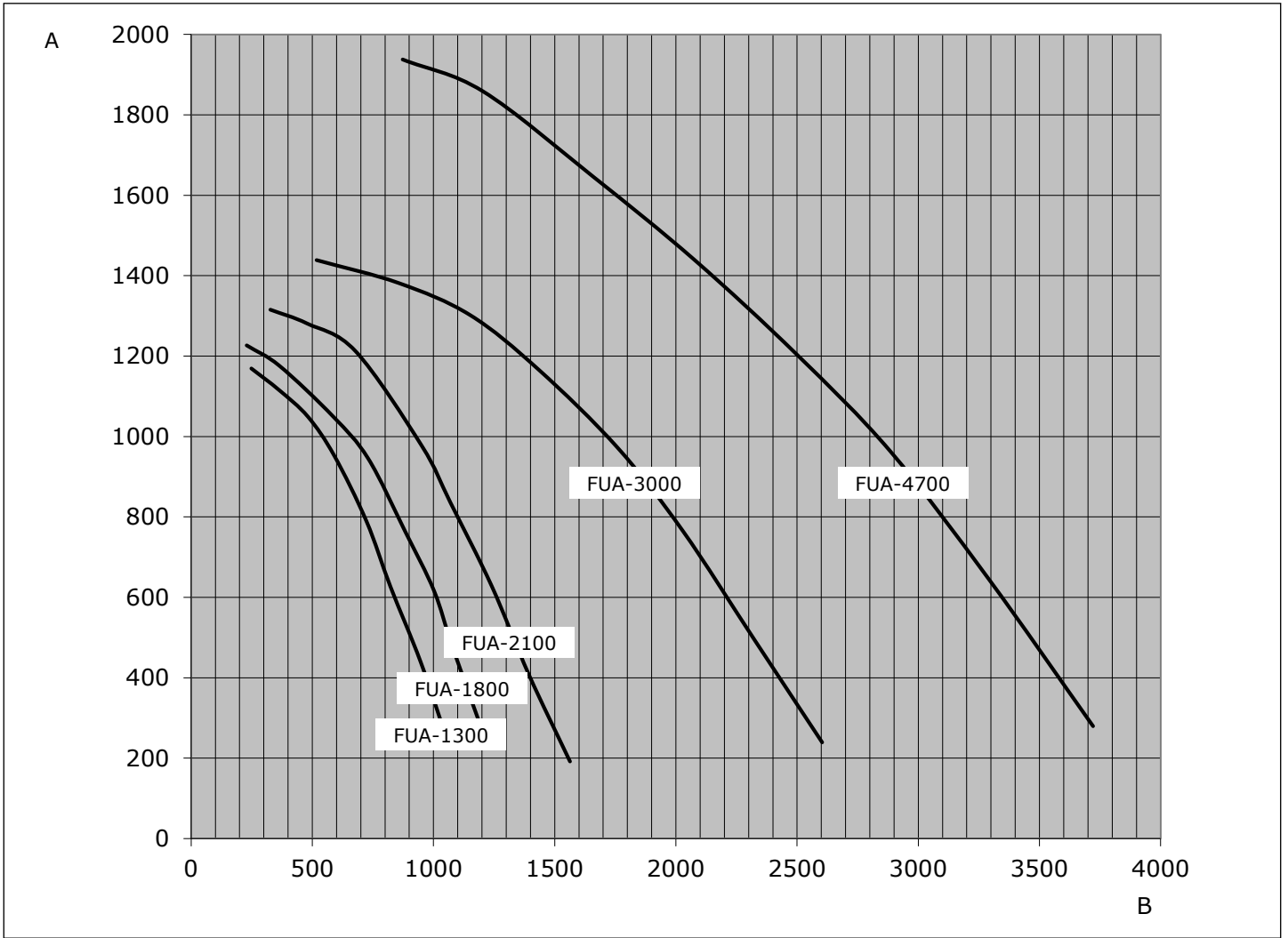

A = Static pressure (Pa)  
 B = Airflow (m³/h)

Fig. III Variable outlet position

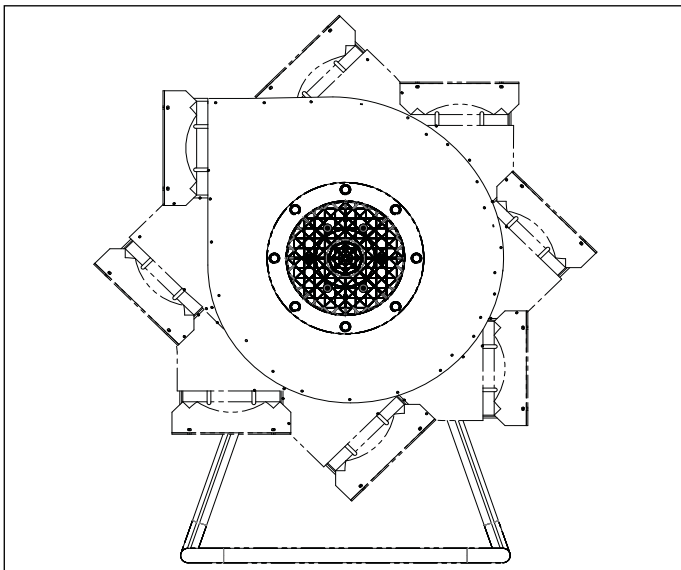
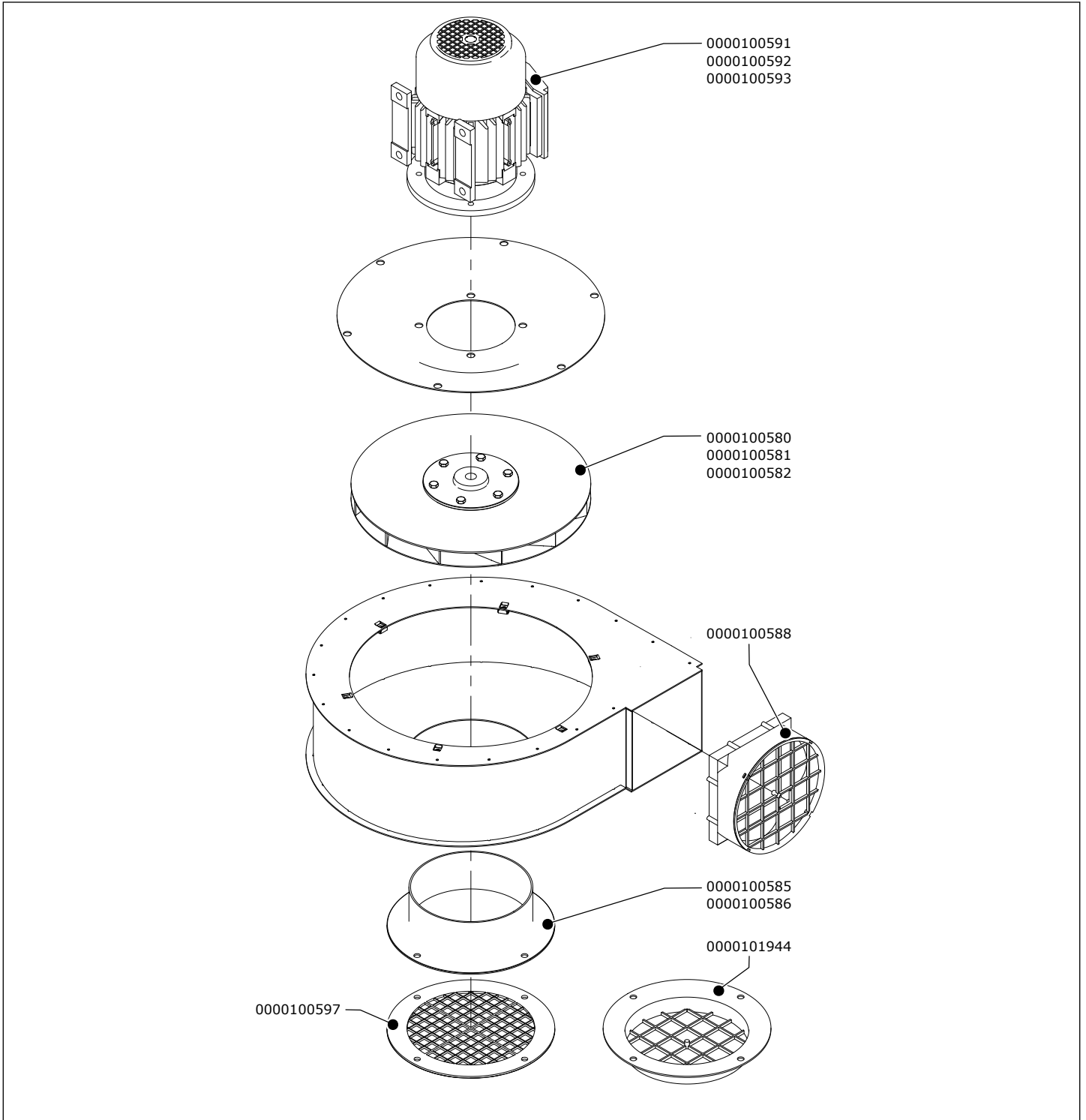

Fig. IV Spare parts FUA-1800/2100



| FUA-1800   | Spare parts                            |
|------------|--|
| 0000100251 | Motor plate FUA-1800 (IEC)             |
| 0000100581 | Fan wheel FUA-1800 (IEC)               |
| 0000100585 | Inlet flange FUA-1800                  |
| 0000100588 | Outlet grid FUA-1800/2100              |
| 0000100591 | Motor 0,55 kW; 230-400V/3ph/50Hz (IEC) |
| 0000100597 | Inlet grid (fine) FUA-1800/2100        |
| 0000101944 | Connection flange with grid            |

| FUA-2100   | Spare parts                                   |
|------------|---|
| 0000100252 | Motor plate FUA-2100/2700 (IEC)               |
| 0000100582 | Fan wheel FUA-2100/2700 (IEC)                 |
| 0000100586 | Inlet flange FUA-2100 (IEC) / FUA-2700 (NEMA) |
| 0000100588 | Outlet grid FUA-1800/2100                     |
| 0000100592 | Motor 0,75 kW; 230-400/460V/3ph/50-60Hz (IEC) |
| 0000100593 | Motor 0,75 kW; 115-230V/1ph/50-60Hz (IEC)     |
| 0000100597 | Inlet grid (fine) FUA-1800/2100               |
| 0000101944 | Connection flange with grid                   |

Fig. V Spare parts FUA-3000/4700

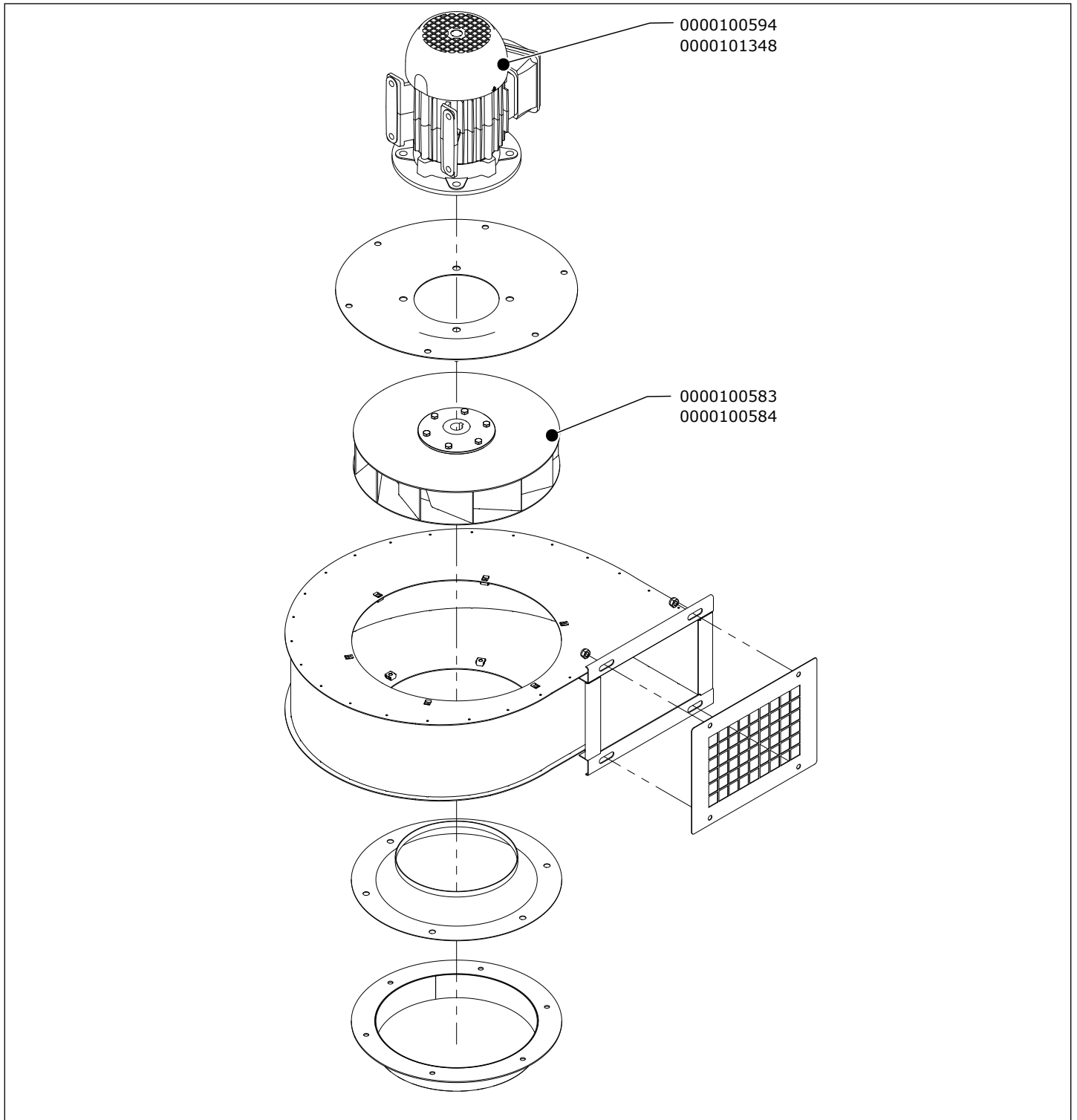

| FUA-3000   | Spare parts                           |
|------------|---------------------------------------|
| 0000100253 | Motor plate FUA-3000 (IEC)            |
| 0000100583 | Fan wheel FUA-3000 (IEC)              |
| 0000100594 | Motor 1,1 kW; 230-400V/3ph/50Hz (IEC) |

| FUA-4700   | Spare parts                           |
|------------|---------------------------------------|
| 0000100584 | Fan wheel FUA-4700 (IEC)              |
| 0000101348 | Motor 2,2 kW; 230-400V/3ph/50Hz (IEC) |
| 0000102528 | Motor plate FUA-4700/TEV-585 (IEC)    |

