

DUALGO^{plus}

STATIONARY FILTER UNIT WITH TWO METAL TUBE ARMS

The DualGo^{plus} is a stationary welding fume filter with integrated fan and two metal tube arms (KUA-160). It contains a disposable filter package.

The DualGo^{plus} has been designed for occasional to regular welding activities (approx. 1 coil of solid wire or 7,5 kg/16.5 lbs of electrodes per workplace per month) and TIG welding.



APPLICATIONS

The DualGo^{plus} is intended to be used for the following applications:

- MIG-MAG/GMAW welding
- TIG welding
- FCAW welding
- stick/MMAW welding
- grinding
- polishing
- finishing



SPECIFICATIONS

■ Physical dimensions and properties	
Material (housing):	electro-zinc coated steel (according to DIN EN 10152)
• steel grade	• DC01+ZE
• steel grade no.	• 1.0330
Colour	yellow RAL 1004 grey RAL 7011
Weight (net), excl. arms	126,5 kg (279 lbs.)
Mains cord	not included
■ Extraction arms	
Type	KUA-160
Material	metal tube
Diameter	Ø 160 mm (6.3 in.)
Hood opening	Ø 300 mm (11.8 in.)
Length per arm:	
• KUA-160/2H	• 2 m
• KUA-160/3H	• 3 m
• KUA-160/4H	• 4 m
Weight per arm:	
• KUA-160/2H	• 12 kg (26.5 lbs)
• KUA-160/3H	• 15.5 kg (34.2 lbs)
• KUA-160/4H	• 18 kg (39.7 lbs)
■ Filters	
Pre filter cassette:	
• material	• polyester
• filter surface	• 1 m ² (10.8 ft ²)
• filter classification	• ISO Coarse 70% according to ISO 16890
• washable	• no
HEPA filter cassette:	
• material	• glass fibre
• filter surface	• 26 m ² (280 ft ²)

• efficiency class	• E12 according to EN 1822-1:2009
• washable	• no
■ Performance	
Fan type	radial
Extraction capacity (incl. extraction arms)	max. 2100 m ³ /h (1200 CFM)
Fan speed	3400 rpm
Noise level (according to ISO 3746)	•
• with silencer SAS-315	
■ Electrical data	
Power consumption	2,2 kW (3 HP)
Available connection voltages	• 208-230V/3ph/60Hz (236) • 460V/3ph/60Hz (536) • 575V/3ph/60Hz (636)
Motor design	NEMA
Energy efficiency	IE3 / premium
■ Ambient and process conditions	
Process temperature:	
• min.	• 5°C (41°F)
• nom.	• 20°C (68°F)
• max.	• 70°C (158°F)
Max. relative humidity	90%
Suitable for outdoor use	no
Storage conditions	• 5-45°C (41-113°F) • relative humidity max. 80%
■ Options and accessories	
SAS-250 straight	silencer
■ Scope of supply	
Stationary filter unit, incl. fan and wall bracket – Extraction arm (pre-assembled) (2) – Rotating flange (2) – Arm swivel ring, incl. rubber collar (2) – Extraction hood (2) – Hood collar with safety mesh (2) – Mounting material – Switch box – Outlet transition rectangular-round Ø 250 mm	

Type	DualGo ^{plus} /2m+2m	DualGo ^{plus} /3m+3m	DualGo ^{plus} /4m+4m
■ Order information			
Connection voltage	Article no.	Article no.	Article no.
208-230V/3ph/60Hz	0000113842	0000113843	0000113844
460V/3ph/60Hz	0000111463	0000111483	0000111495
575V/3ph/60Hz	0000111464	0000111484	0000111496
Number/package	1	1	1
■ Logistics data			
Gross weight (incl. pallet)	169 kg (373 lbs.)	182 kg (401 lbs.)	184 kg (406 lbs.)
Packing dimensions (incl. pallet)	80 x 120 x 135 cm (31.5 x 47.2 x 53.1 in.)	100 x 120 x 175 cm (39.8 x 47.2 x 68.9 in.)	100 x 120 x 225 cm (39.8 x 47.2 x 88.6 in.)
Max. number/pallet	1	1	1
Harmonized Tariff Code	84213925	84213925	84213925

Type	DualGo ^{plus} /2m+3m	DualGo ^{plus} /2m+4m	DualGo ^{plus} /3m+4m
■ Order information			
Connection voltage	Article no.	Article no.	Article no.
208-230V/3ph/60Hz	0000113845	0000113846	0000113847
460V/3ph/60Hz	0000111501	0000111507	0000111513
575V/3ph/60Hz	0000111502	0000111508	0000111514
Number/package	1	1	1
■ Logistics data			
Gross weight (incl. pallet)	178 kg (392 lbs.)	181 kg (399 lbs.)	183 kg (403 lbs.)
Packing dimensions (incl. pallet)	100 x 120 x 175 cm (39.8 x 47.2 x 68.9 in.)	100 x 120 x 225 cm (39.8 x 47.2 x 88.6 in.)	100 x 120 x 225 cm (39.8 x 47.2 x 88.6 in.)
Max. number/pallet	1	1	1
Harmonized Tariff Code	84213925	84213925	84213925

DIMENSIONS

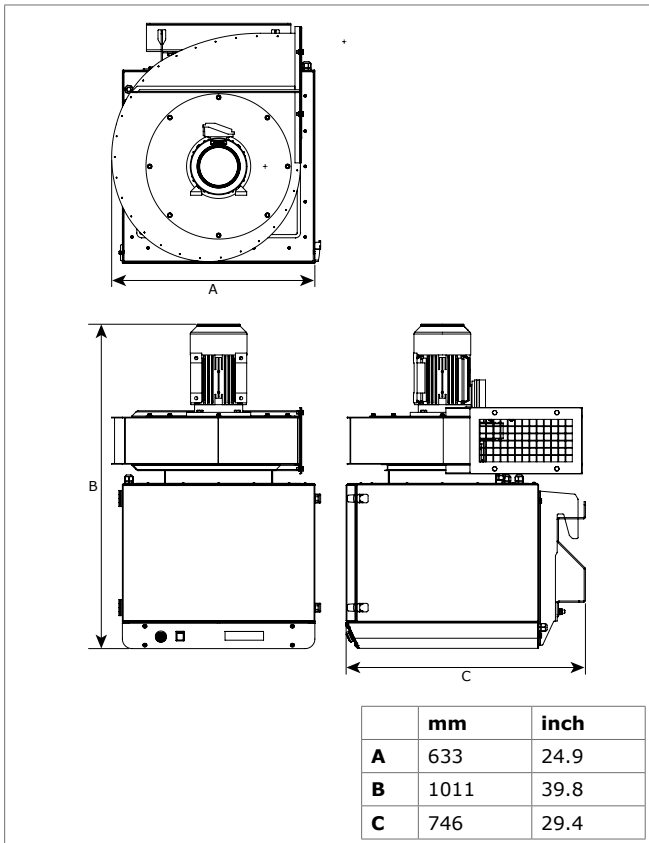

WORKING RANGE

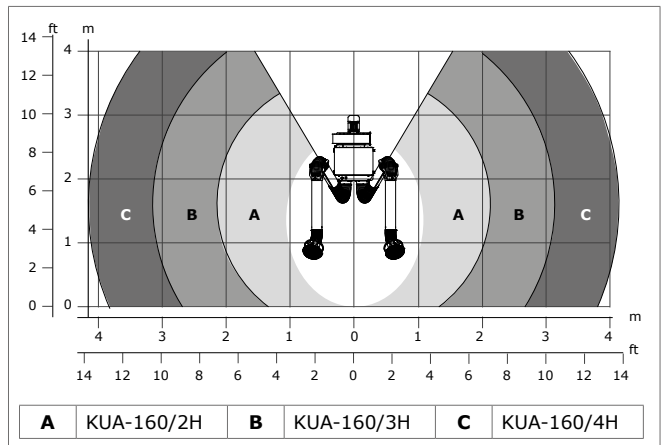

FEATURES & BENEFITS



Compact design

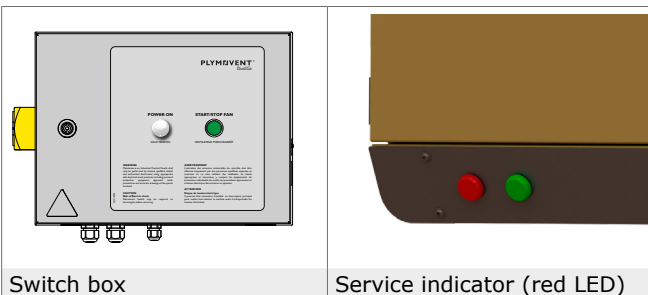

Switch box

Service indicator (red LED)

APPROVALS/CERTIFICATES

	<p>UL 508A (on switch box only)</p>
---	-------------------------------------

Application restrictions

Do **not** use the product for the following applications or in the following circumstances: polishing applications in combination with grinding, welding or any other application that generate sparks (fibres from polishing or abrasive flap disks are highly flammable and pose a high risk of filter fires when exposed to sparks) | aluminium laser cutting | oil mist | heavy oil mist in welding fume | arc-air gouging | extraction of aggressive fumes and gases (e.g. from acids, from alkaline, from soldering paste containing lithium) | extraction of hot gases (more than 70°C/158°F continuously) | grinding aluminum and magnesium | flame spraying | extraction of cement, saw dust, wood dust etc. | sucking cigarettes, cigars, oiled tissues and other burning particles, objects and acids | explosive environments or explosive substances/gases

Product type

DualGo^{plus}

Article no.

refer to Order information

Product category

stationary filter units

Version

270521/B

Always check the latest version on www.plymovent.com