

MOTORIZED HOSE REEL

VEHICLE EXHAUST EXTRACTION REEL

The motorized hose reel (MHR) is designed to retract the hose via an electric motor. The MHR is operated up and down by means of a mobile wired control, wall mounted or remote control. This hose reel is ideal for general and light duty vehicle workshops.

With the hose safely elevated, other equipment in the workshop can be operated safely. This hose reel also limits potential damage to personnel and vehicles. The MHR maximum lifting capacity is 40 lbs (18 kg).*

* at hose diameter 6 in. (150 mm)

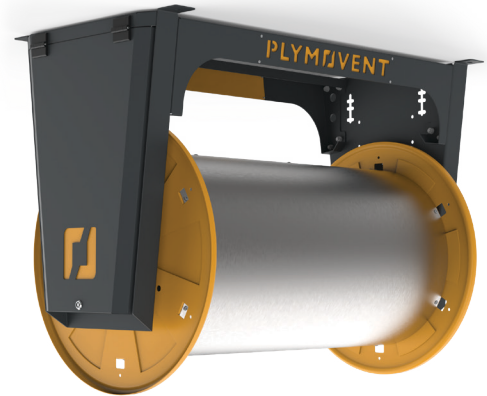

APPLICATIONS

The MHR is intended to be used for the following applications:



- To eliminate hazardous vehicle exhaust emissions with our vehicle exhaust capture and removal systems for the following segments: fire and emergency service stations as well as military facilities.

SPECIFICATIONS

■ Physical dimensions and properties		
Material	<ul style="list-style-type: none"> frame <ul style="list-style-type: none"> textured powder coat galvanized steel drum <ul style="list-style-type: none"> textured powder coat galvanized steel and galvanized steel 	
Colour	<ul style="list-style-type: none"> frame <ul style="list-style-type: none"> iron grey (RAL 7011) drum sidewheels <ul style="list-style-type: none"> yellow (RAL 1004) 	
■ Performance		
Power supply	110/120V	230V
Phase	Single phase	Single phase
Current	2.5A	1.25A
Frequency	60 Hz	50/60 Hz
Output	270W	290W
Speed	14 rpm	12/14 rpm
Lifting capacity (at hose diameter 6 in. (150 mm))	40 lbs (18 kg)	40 lbs (18 kg)
■ Ambient conditions		
Operating temperature:	<ul style="list-style-type: none"> min. <ul style="list-style-type: none"> 32°F (0°C) nom. <ul style="list-style-type: none"> 68°F (20°C) max. <ul style="list-style-type: none"> 104°F (40°C) 	
Max. relative humidity	80%	
Outdoor use allowed	no	

Storage conditions	<ul style="list-style-type: none"> 32 - 68°F (0 - 40°C) relative humidity max. 80%
■ Options and accessories	
Automatic damper MHR-CB MSR-24/2 switch for automatic fan start and/or damper control	
■ Scope of supply	
Hose reel hose and nozzle to be ordered separately	
■ Order information	
Article no.	refer to order specifications
Number/package	1
■ Shipping data	
Gross weight	215 lbs (75 kg)
Packing dimensions	62 x 32 x 45 in. (1575 x 815 x 1145 mm)
Harmonized Tariff Code	84219990
Country of origin	United States

ORDER SPECIFICATIONS

Art. no.	Description
0000301690	MHR-850-Drive-215
0000302167	MHR-850-Drive-116
0000302254	MHR-850-Drive-215-AD
0000302258	MHR-850-Drive-116-AD
0000301773	MHR-1050-Drive-215
0000302168	MHR-1050-Drive-116
0000302256	MHR-1050-Drive-215-AD
0000302259	MHR-1050-Drive-116-AD

- * 116 = single phase, 110/120 V 60 Hz
 215 = single phase, 230 V 50 Hz
 216 = single phase, 230 V 60 Hz
 MHR = motorized hose reel
 AD = automatic damper

DIMENSIONS

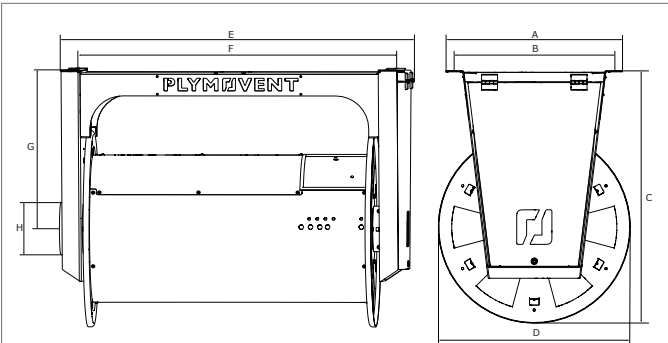

	MHR-850	MHR-1050
A	21.7 in. (552 mm)	21.7 in. (552 mm)
B	19.7 in. (500 mm)	19.7 in. (500 mm)
C	31 in. (789 mm)	31 in. (789 mm)
D	23.6 in. (600 mm)	23.6 in. (600 mm)
E	42.3 in. (1075 mm)	50.2 in. (1275 mm)
F	38.4 in. (975 mm)	46.3 in. (1175 mm)
G	19.3 in. (489 mm)	19.3 in. (489 mm)
H	Ø 6.3 in. (160 mm)	Ø 6.3 in. (160 mm)

FEATURES & BENEFITS

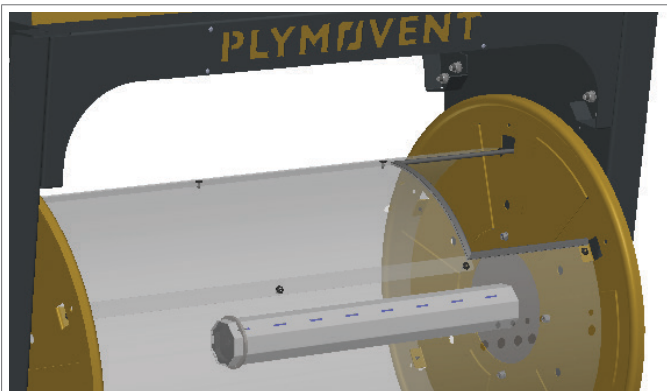

Integrated tubular motor

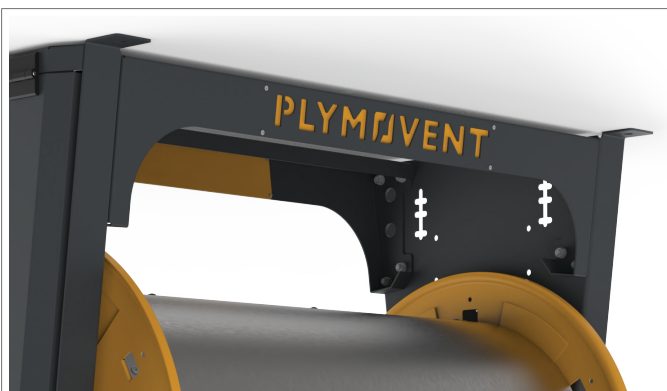

Sturdy frame

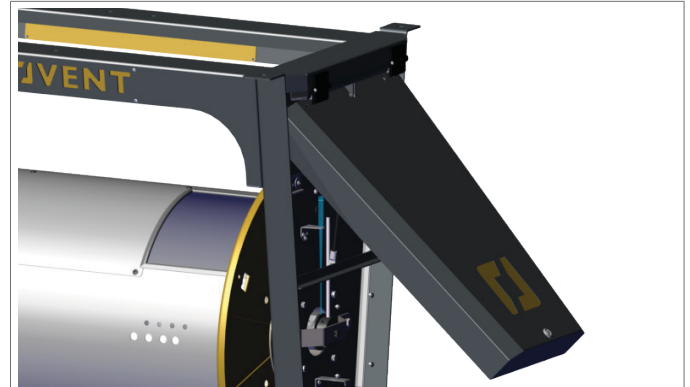

Easy installation and service by robust hatch with gas spring support

PRESSURE LOSS

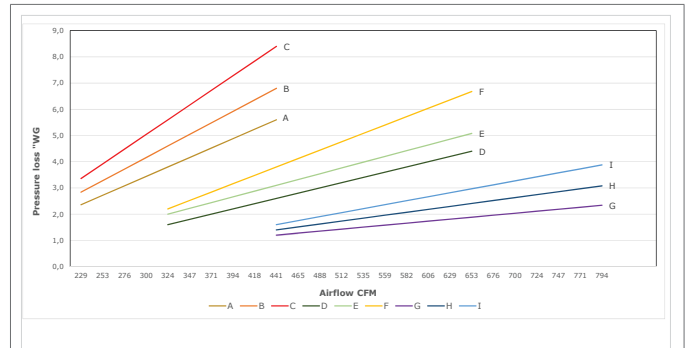

The diagram shows the pressure loss in the hose reels at different airflows in uncoiled position.

Read the diagram at the recommended airflows:
Cars 211 cfm (360 m³/h)
Trucks 635 cfm (1080 m³/h)

	Hose diameter	Hose length
A	Ø 4 in. (100 mm)	7,5 m
B	Ø 4 in. (100 mm)	10 m
C	Ø 4 in. (100 mm)	12,5 m
D	Ø 5 in. (125 mm)	7,5 m
E	Ø 5 in. (125 mm)	10 m
F	Ø 5 in. (125 mm)	12,5 m
G	Ø 6 in. (150 mm)	7,5 m
H	Ø 6 in. (150 mm)	10 m
I	Ø 6 in. (150 mm)	12,5 m

Product type	MHR
Article no.	see order specifications
Product category	hose reels
Version	200123/A

Always check the latest version on www.plymovent.com