

**PLYMVENT®**

clean air at work

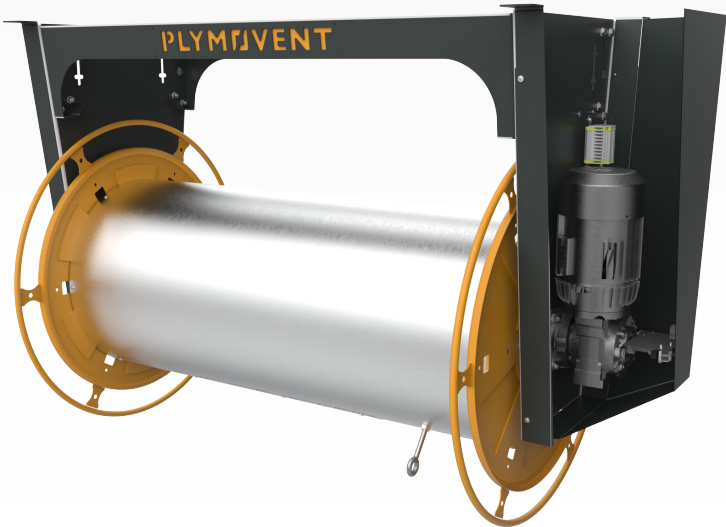

**MER MOTORIZED EXHAUST HOSE REEL**



---

---

#### **EN - ORIGINAL INSTRUCTION**

All rights reserved. The information given in this document has been collected for the general convenience of our clients. It has been based on general data pertaining to construction material properties and working methods known to us at the time of issue of the document and is therefore subject at anytime to change or amendment, and the right to change or amend is hereby expressly reserved. Changes may be made with or without notification, it is the users responsibility to ensure they have attained the most recent copy of this document for their files. The instructions in this publication only serve as a guideline for installation, use, maintenance and repair of the product mentioned on the cover page of this document. This publication is to be used for the standard model of the product of the type given on the cover page. Thus the manufacturer cannot be held responsible for any damage resulting from the application of this publication to the version actually delivered to you. This publication has been written with great care. However, the manufacturer cannot be held responsible, either for any errors occurring in this publication or for their consequences.





---

---

## TABLE OF CONTENTS

<b>ENGLISH</b>		<b>Page</b>
	Preface	
1	Introduction	3
2	Product description	4
3	Safety	4
4	Installation	5
5	Pressure loss calculation	10
6	Electrical diagram	11
7	MER spare parts	13
	Declarations	13

## GENERAL PRECAUTIONS

	<b>ATTENTION</b> Allow only qualified personnel familiar with adjustable frequency AC drives, and associated machinery to plan or implement the installation, start-up and subsequent maintenance of the system. Failure to comply can result in personal injury and/or equipment damage.
	<b>ATTENTION</b> To avoid an electric shock hazard, verify that the voltage on the bus capacitors has discharged before performing any work on the electrical controls, switches and/or drives if applicable.
	<b>ATTENTION</b> Incorrectly applied or installed electrical controls, switches and/or drives can result in component damage or a reduction in product life. Wiring or application errors, such as, undersizing the motor, incorrect or inadequate AC supply, or excessive ambient temperatures can result in malfunction of the system.
	<b>ATTENTION</b> The electrical controls, switches and/or drives may contain ESD (Electrostatic Discharge) sensitive parts and assemblies. Static control precautions may be required when installing, testing, servicing or repairing this assembly. Component damage can result if ESD control procedures are not followed.

### IMPORTANT USER INFORMATION

Read this document in entirety before you install, configure, operate, or maintain this product. Users are required to familiarize themselves with installation and wiring instructions in addition to requirements of all applicable codes, laws and standards.

Activities including installation, adjustments, putting into service, use, assembly, disassembly, and maintenance are required to be carried out by suitably trained personnel in accordance with applicable code of practice.

If this equipment is used in a manner not specified by the manufacturer, the protection provided by the equipment may be impaired.



In no event will Plymovent be responsible or liable for indirect or consequential damages resulting from the use or application of this equipment.

The examples and diagrams in this manual are included solely for illustrative purposes. Because of the many variables and requirements associated with any particulate installation, Plymovent cannot assume responsibility or liability for actual use based on the examples and diagrams.

No patent liability is assumed by Plymovent with respect to use of information, circuits, equipment, or software that may be described in this manual. Throughout this manual, when necessary, notes may be used to make you aware of safety considerations.



The operation of exhaust extraction systems can be affected by various factors including but not limited to proper design of the system, operating procedures, service and maintenance. Fume exhaust exposure levels should be checked upon installation and periodically thereafter to ensure that they fall within applicable regulations and exposure limit values.

Plymovent systems are made code compliant, please ensure the system is properly designed, operated, serviced and maintained.

	<b>WARNING!</b> Identifies information about practices or circumstances that can cause an explosion in a hazardous environment, which may lead to personal injury, death, property damage, or economic loss.
	<b>ATTENTION</b> Identifies information about practices or circumstances that can lead to personal injury or death, property damage, or economic loss. Attentions help you identify a hazard, avoid a hazard, and recognize the consequent.

### IMPORTANT

Identifies information that is critical for successful application and understanding of the product.

	<b>SHOCK HAZARD</b> Labels may be on outside or inside of the equipment, for example control box, to alert people that dangerous voltage may be present.
	<b>ARC FLASH HAZARD</b> Labels may be on outside or inside of the equipment, for example control box, to alert people to potential Arc Flash. Arc Flash will cause severe injury or death. Wear proper Personal Protection Equipment (PPE). Follow ALL regulatory requirements for safe work practices and for Personal Protective Equipment (PPE).

**BE SURE THAT ALL INSTALLATION, OPERATION, MAINTENANCE AND REPAIR PROCEDURES ARE PERFORMED ONLY BY QUALIFIED INDIVIDUALS.**





## PREFACE

### Using this manual

This manual is intended to be used as a work of reference for professional, well trained and authorized users to be able to safely install, use, maintain and repair the product mentioned on the cover of this document.

### Pictograms and symbols

The following pictograms and symbols are used in this manual:

	<b>ATTENTION</b> A remark with additional information for the user. A remark brings possible problems to the user's attention.
	<b>CAUTION!</b> Procedures, if not carried out with the necessary caution, could damage the product, the workshop or the environment.
	<b>WARNING!</b> Procedures which, if not carried out with the necessary caution, may damage the product or cause serious personal injury.
	<b>CAUTION!</b> Risk of electric shock.
	<b>WARNING!</b> Fire hazard! Important warning to prevent fire.

### Text indicators

Listings indicated by "-" (hyphen) concern enumerations.  
Listings indicated by "•" (bullet point) describe steps to perform.

### Service and technical support

For information about specific adjustments, maintenance or repair jobs which are not dealt with in this manual, please contact your Plymovent authorized distributor. To locate the distributor for your area, visit [www.plymovent.com](http://www.plymovent.com) and click "Contact us," then "Sales offices."

## 1 INTRODUCTION

### 1.1 Identification of the product

The identification sticker on the hose reel, as shown in Fig. 1.2, contains the following:

- product name
- serial number
- year in which hose reel was manufactured

### 1.2 General description

The Motorized Exhaust Hose Reel (MER) reduces the occupational health risks from vehicle exhaust fumes and enables the hose to be stored conveniently when not in use. MER is designed for automobile, truck, bus and construction off-road vehicle workshops with high ceilings and high-temperature hoses.

The single phase version has a lifting capacity of 75 lbs (35 kg) and the 3 phase version has a lifting capacity of 110 lbs (50 kg).

### 1.3 Product combinations

This product is compatible with Plymovent fans, hoses, nozzles and articulated boom arm.

### 1.4 Technical data

Here is an overview of MER components. MER also features several options, such as motor output, hoses and lengths, mechanical dampers, and direct mount fan.

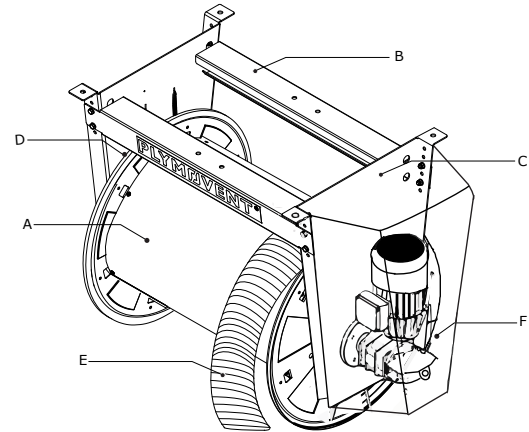

Fig. 1.1 MER hose reel with hose

- A. Hose reel drum provides a secure and space-friendly storage location for the hose:
  - smooth, zinc-plated drum on which the hose rolls;
  - drum end plates are powder-coated yellow.
- B. Console - zinc-coated steel frame provides support and strength for longevity and robustness.
- C. A-frame - primed and powder-coated steel.
- D. Adapter Ø 6.3 in. (160 mm) to fan or central exhaust system.
- E. Hose - not included.
- F. Electrical junction box and motor - for landing wires and connection of control equipment; includes a reliable self-locking bevel gear drive, limit switches and thermal overload protection.

Note: For North America, MER includes a 160 to 150 mm (6.25 to 6 in.) reducer to decrease the diameter of the hose when making connections to standard 150 mm (6 in.) ductwork.

Note: A standard, wall-mounted control box for up/down operation is provided. Hanging pendant and wireless controller options are available.



Fig. 1.2 MER identification sticker

### 1.4.1 Set the adjusting screw

During installation, installers must remove the motor cover and using an allen wrench, set the start/stop hose position by turning the adjusting screws on the three on/off limit switches (A) in the gear box.



**WARNING!**  
Remember to tighten the lock nuts on the adjusting screws after setting the hose position, as vibrations from the hose reel may loosen these nuts over time.

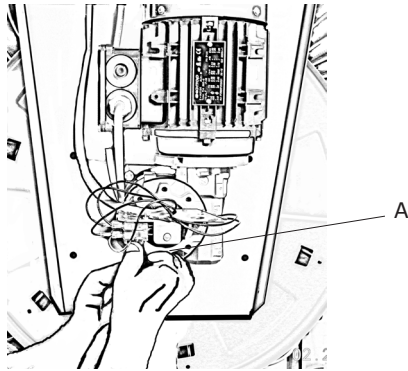

Fig. 1.3 Setting limit switches on MER

Note: An additional limit switch is available (B) to connect to a Plymovent SA-24, ES-90 or DCV controller to be used as a fan start signal.

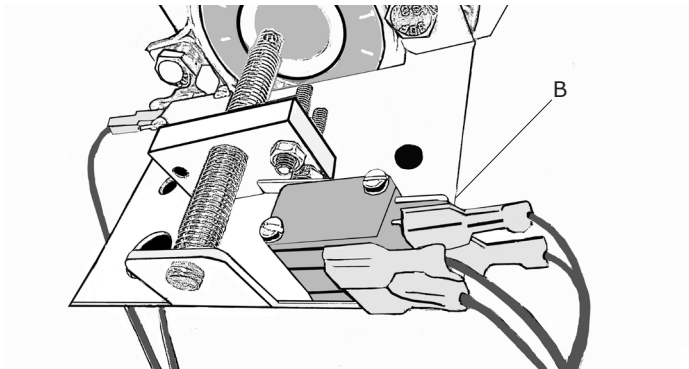

Fig. 1.4 MER hose limit switches with switch for controller.

### 1.4.2 Max Hose Length

The maximum hose length that MER supports is dependent on the specific version of MER hose reel ordered, the type and size of the hose, and the type of the nozzle.

For example, up to 41 ft (12,5 m) of the HT-750 hose (6 in. diameter) can be placed on MER. The table below demonstrates the total weight of the Plymovent HT-750 hose and REGD nozzle. Each system's total weight will vary.

Component	Weight calculation	Total weight
6 in. (150 mm) HT-750 Hose	1.15 lbs/ft (1,71 kg/m)	47 lbs (21,3 kg)
Rubber nozzle REGD-150-160	4.4 lbs (2 kg)	4.4 lbs (2 kg)
Total weight of hose and nozzle		52 lbs (17,4 kg)
MER lifting capacity (Single Phase)		75 lbs (34 kg)

### 1.4.3 Power, Frequency, Motor Output, Motor Current and Revs/min

Product no: MER-XXX	Phase	Power Supply (V)	Frequency (Hz)	Motor Output hp (kW)	Motor Current (A)
850/1050	1	120	60	0.75 (0.55)	7 - 7.5
850/1050	3	230/460	50/60	0.75 (0.55)	2.85 / 1.65
850/1050	3	230/460	50/60	0.75 (0.55)	2.85 / 1.65
1250	1	120	60	0.75 (0.55)	7 - 7.5
1250	3	230/460	50/60	0.75 (0.55)	2.85 / 1.65

### 1.4.4 Weight and lifting capacity

Product	Weight (lbs/kg)	Lifting capacity (lbs/kg)
MER-850 1 Phase	137 (62 )	75 (34)
MER-850 3 Phase	137 (62)	110 (50)
MER-1050 1 Phase	148 (67)	75 (34)
MER-1050 3 Phase	148 (67)	110 (50)
MER-1050-200 1 Phase	165 (75)	75 (34)
MER-1050-200 3 Phase	165 (75)	110 (50)



Refer to the available product data sheet for detailed product specifications.

### 1.5 Dimensions

Refer to Section 4.2 and 4.3 for dimensions and weights.

### 1.6 Transport of the unit

The manufacturer cannot be held liable for any transportation damage after delivery of the unit. Always handle the unit and the accompanying options and/or accessories, if any, with care. MER is delivered with four mounting tabs/feet for wall or ceiling mounting. The motor is fitted with limit switches to control the up/down positions.

Note: As an alternative to MER being connected to a ductwork system, Plymovent fans FUA-1800, 2100 or 2700 can be directly mounted to the hose reel. Hose, fan(s), starters and tailpipe adapters must be ordered separately or with Ø 6 in. (160 mm) hose for connection with a central exhaust system. Hose and nozzle must be ordered separately.

---

---

## 2 PRODUCT DESCRIPTION

### 2.1 Operation

Operating the hose reel is done by one of these up/down control systems:

- Control Box with Up/Down push buttons
- Optional: hanging pendant
- Optional: wireless controller

No matter which controller is chosen, a button must be depressed to uncoil and roll up the hose until the required position (also known as the set limit) is reached.

Note: The two optional controllers listed above must be ordered separately as an accessory.



#### **WARNING!**

Be careful when operating the hose reel so as to avoid damage to persons and property.

## 3 SAFETY

### General

The manufacturer does not accept any liability for damage to the product or personal injury caused by ignoring the safety instructions in this manual, or by negligence during installation, use, maintenance, and repair of the product mentioned on the cover of this document and any corresponding accessories. Specific working conditions or used accessories may require additional safety instructions. Immediately contact your supplier if you detect a potential danger when using the product.

**The user of the product is always fully responsible for observing the local safety instructions and regulations.**

### User manual

- Everyone working on or with the product must be familiar with the contents of this manual and must strictly observe the instructions therein. The management should instruct the personnel in accordance with the manual and observe all instructions and directions given.
- Never change the order of the steps to perform.
- Always keep the manual with the product.

### Pictograms and instructions on the product (if present)

- The pictograms, warning and instructions attached to the product are part of the safety features. They must not be covered or removed and must be present and legible during the entire life of the product.
- Immediately replace or repair damaged or illegible pictograms, warnings and instructions.

### Users

The use of this product is exclusively reserved to authorized, trained and qualified users. Temporary personnel and personnel in training can only use the product under supervision and responsibility of skilled engineers.

### Intended use<sup>1</sup>

The product has been designed as a motorized hose reel to extract exhaust gases. Using the product for other purposes is

<sup>1</sup> "Intended use" as explained in EN-ISO 12100 is the use for which the technical product is suited as specified by the manufacturer, inclusive of his directions in the sales brochure. In case of doubt it is the use which can be deduced from the construction, the model and the function of the technical product which is

considered contrary to its intended use. The manufacturer accepts no liability for any damages or injury resulting from such use. The product has been built in accordance with state-of-the-art standards and recognized safety regulations. Only use this product when in technical perfect condition in accordance with its intended use and the instructions explained in the user manual.

### Technical specifications

The specifications given in this manual must not be altered.

### Modifications

Modification is not allowed.

### Installation

- The installation of this product is exclusively reserved to authorized, well-trained and qualified engineers.
- Inspect the product and check it for damage. Verify the functioning of the safety features.
- Never install the product in front of entrances and exits which must be used for emergency services.
- Make sure that the workshop, in the vicinity of the product, contains sufficient approved fire extinguishers.

### Tools

These tools are needed to install the MER system:

- Battery screw gun
- Screw drivers
- Misc hand tools and wrenches
- Allen wrench set

Please note that additional tools and machines may be needed depending on the installation situation (installation height, space available etc).

### Use

- Check the working environment. Do not allow unauthorized persons to enter the working environment.
- Protect the product against water and humidity.
- Use common sense. Stay alert and keep your attention to your work. Do not use the product when you are under the influence of drugs, alcohol or medicine.
- Make sure the room is always sufficiently ventilated; this applies especially to confined spaces.

---

considered normal use. Operating the machine within the limits of its intended use also involves observing the instructions in the user manual.

## Service, maintenance and repairs

	<b>WARNING!</b> Maintenance should only be performed by authorized, qualified and trained persons (skilled) using appropriate work practices.
--	--

## 4 INSTALLATION

	<b>WARNING!</b> Do not attempt installation of this unit unless you are familiar with the necessary tools, equipment, utility connections and potential hazards. Installation should be performed only by a qualified service provider. Failure to do so could result in reduced performance of the unit, serious personal injury or death.
--	--

	<b>ATTENTION</b> The MER hose reel is delivered without cables for external field wiring. When using the MSR microswitch all interconnect cables/wire size used shall comply with the local requirements.
--	--

### 4.1 Assembly

To assemble the MER-850, MER-1050 and MER-1250, complete the following steps:

- Dismantle drum lid.
- Mount MAP-kit (A) (except for 8 in (20 mm) hose reels, as MAP-kit is not needed).
- Mount hose to the socket inside the drum using clamp (B).
- Bend hose into a natural soft curve and fasten it using clamp (C).
- Re-mount the drum lid.
- Mount the edge protection (D) at the opening of the drum where the hose protrudes.
- Start the motor, coil up the hose and set the limit switches for up and down.
- Check the console holes to ensure they are set for the 6 in. (150 mm) hole position (E), as shown in fig. 4.1b. The console provides multiple holes for Plymovent spring operated hose reels, and these do not need to be adjusted for MER.

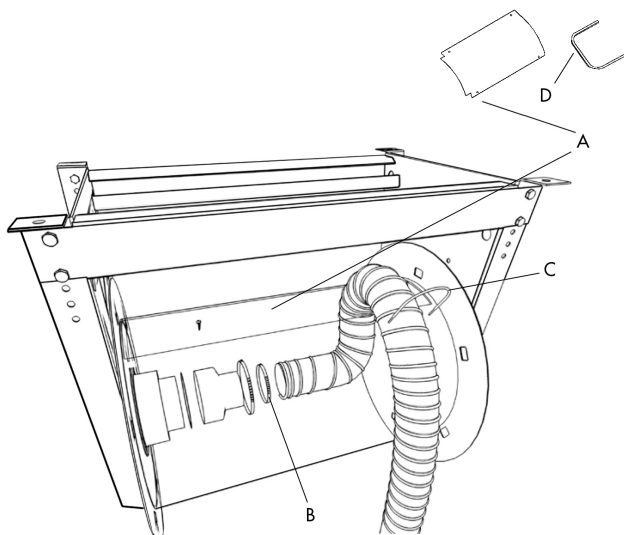

Fig. 4.1a Hose reel assembly

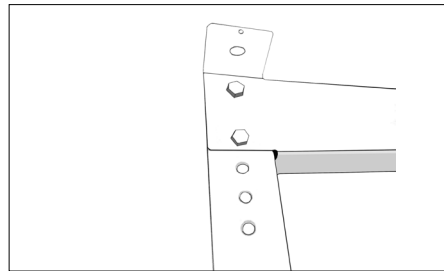

Fig. 4.1b Console holes

### 4.2 MER reach and coverage

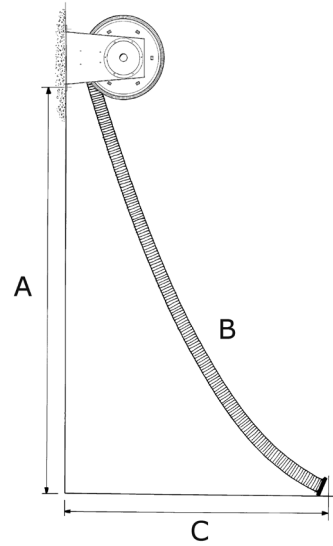

Fig. 4.2 Hose reel reach and mounting height

#### 4.2.1 Reach and mounting height

- A = Mounting height
- B = Hose length
- C = Max. reach

Measurements in ft. (m).

Hose length	Mounting height	Maximum reach
25 ft (7,5 m)	9.8 ft (3 m)	20.4 ft (6,2 m)
	11.5 ft (3,5 m)	19.4 ft (5,9 m)
	13.1 ft (4 m)	18 ft (5,5 m)
	15 ft (4,5 m)	17.1 ft (5,2 m)
	16.4 ft (5 m)	15.5 ft (4,7 m)
33 ft (10 m)	11.5 ft (3,5 m)	28 ft (8,5 m)
	13.1 ft (4 m)	27.3 ft (8,3 m)
	15 ft (4,5 m)	26.3 ft (8 m)
	16.4 ft (5 m)	25.3 ft (7,7 m)
	18 ft (5,5 m)	24.3 ft (7,4 m)
41 ft (12,5 m)	16.4 ft (5 m)	35 ft (10,6 m)
	18 ft (5,5 m)	34 ft (10,3 m)
	19.7 ft (6 m)	33 ft (10 m)
	21.4 ft (6,5 m)	32 ft (9,7 m)
	23 ft (7 m)	31 ft (9,4 m)



#### 4.2.2 Dimensions

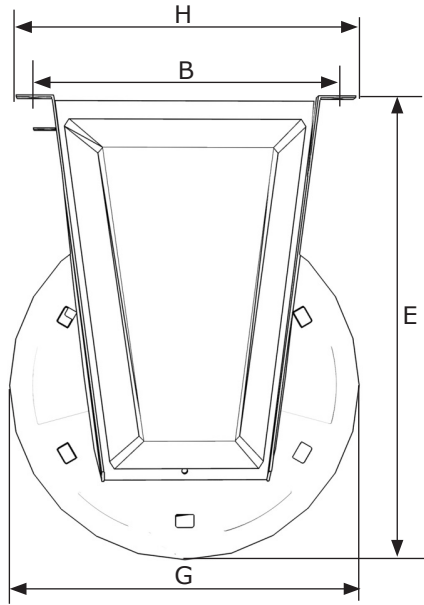

Fig. 4.2.2a Hose reel side view

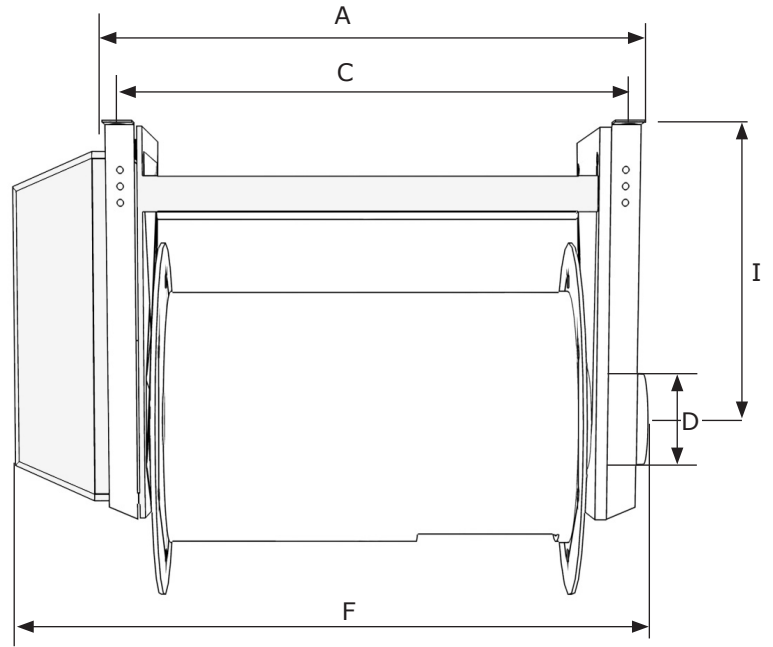

Fig. 4.2.2b Hose reel front view

DIMENSIONS (NOMINAL)			
	MER-850	MER-1050	MER-1250-200
A	40.5 in. (1030 mm)	48.4 in. (1230 mm)	56.3 in. (1430 mm)
B	19.7 in. (500 mm)	19.7 in. (500 mm)	20.7 in. (525 mm)
C	38.3 in. (974 mm)	46.2 in. (1174 mm)	54 in. (1374 mm)
D	Ø 6.3 in. (160 mm)	Ø 6.3 in. (160 mm)	Ø 8 in. (200 mm)
E	31 in. (790 mm)	31 in. (790 mm)	44 in. (1117 mm)
F	48.4 in. (1230 mm)	56.3 in. (1430 mm)	63.8 in. (1620 mm)
G	23.6 in. (600 mm)	23.6 in. (600 mm)	28.9 in. (735 mm)
H	21.7 in. (552 mm)	21.7 in. (552 mm)	22.7 in. (577 mm)
I	19.3 in. (490 mm)	19.3 in. (490 mm)	23.4 in. (590 mm)



#### ATTENTION

When horizontally mounting a reel that contains either a 6 in. or 8 in. (150 mm or 200 mm) hose, it is recommended that you attach the hose so that it rotates around the "front" of the hose reel drum (away from the column or wall), as shown in Fig. 4.2.2c.

This will prevent the hose from scraping the horizontal "console" bar, or colliding with any items attached to the column or wall below the reel.

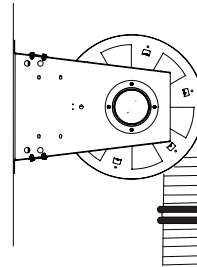

Fig. 4.2.2c Hose rotating away from column or wall

### 4.3 Adjusting the Limit Switches

1. Adjusting screw block
  2. Set screw
  3. "Down" Limit switch
  4. Limit switch lock nut
  5. Adjusting screw
  6. "Up" Limit switches
- Unroll the hose to desired position.
  - Remove the motor case, then loosen the lock nut on the threaded set screw (2). Adjust the set screw until you hear the "Down" limit switch (3) click off.
  - Wind up the hose to the preferred recoiled position.
  - Adjust switch (4) with adjusting screw (5).
  - Check and adjust desired position. A quarter turn on the adjusting screw corresponds to 1 in. (24 cm).
  - Make sure to tighten adjusting screws lock nuts (1). Then adjust the "Up" limit switch (6) until on/off position corresponds with switch.

Note: The "up" limit switch can be used for a fan start switch when paired with a Plymovent SA-24/ES-90 or DCV controller.

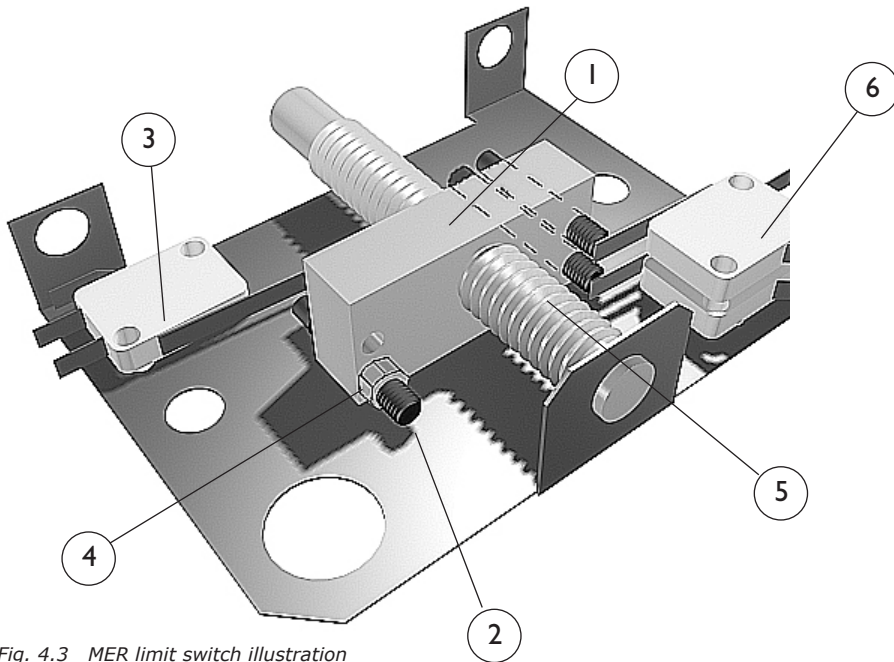

Fig. 4.3 MER limit switch illustration

### 4.4 Check MER terminal box wiring

Plymovent recommends you check the MER motorplate wiring. Based on the model selected, the factory motorplate wiring will be configured for 115V, 230V or 460V, as shown in fig. 4.4b. The terminal box plate will indicate "Delta" and "Y" symbol for 230V and 460V, respectively.

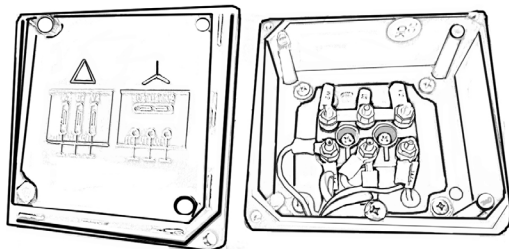

Fig. 4.4a Example of MER terminal box wiring

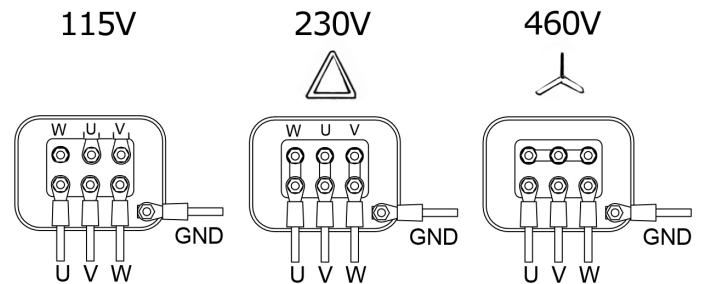

Fig. 4.4b MER terminal box wiring diagram

## 4.5 Mounting options

### 4.5.1 Direct mount fan

MER includes ceiling or wall mounting feet as a standard. All versions - except the 8 in. (200 mm) hose reel - can be fitted with a direct mount fan. Either for connection to a central exhaust system or fitted with a fan, as Fig. 4.5.1a through 4.5.1d explain. Follow these steps:

- Mount the fan with the reel upside down on the floor and then mount the complete reel to its intended position.
- Attach bracket to reel (A)
- Fit rubber collar folded to socket (B)
- Screw fan to bracket (C)
- Unfold rubber collar over the reel's socket (For North America customers, a synthetic rubber-coated sleeve is applied) (D)



#### CAUTION!

Make sure the supporting structure on which the unit will be mounted can handle the dynamic load associated with the hose reel. Always consult a structural engineer prior to installation, to ensure compliance with all local codes.

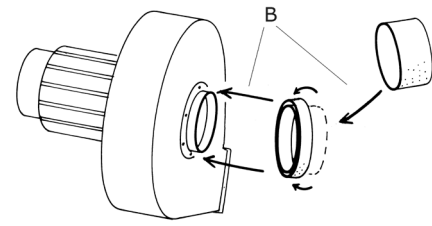

Fig. 4.5.1a Inserting the DMF Bracket into the hose reel

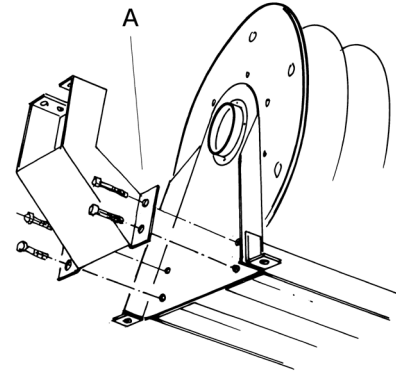

Fig. 4.5.1b Inserting the DMF Bracket into the hose reel

### 4.5.2 Option: MER on articulated arm

Product No.	Reach mm (ft)	Max stretching/ bolt kp (lbs)	Torque demands/ bolt kp (lbs)
EB-3.5	3500 (11.5)	650 (1430)	1950 (4290)
EB-4.5	4500 (14.7)	900 (1984)	2700 (5940)

This option is not available for 8 in. (200 mm) hose reels. Follow these steps to install the articulated arm:

- Bolt mounting bracket to wall or steel column
- Mount the fan (if included)
- Mount the extractor arm
- While attaching the reel and duct, set the friction by tightening the bolt at swivel joint, until the arm remains in one position
- Mount hose reel to boom arm
- Mount spiro-tubing and hose on the extractor arm
- Mount ducting bend to hose reel, then mount the hose to the ducting bend
- Re-adjust friction as needed

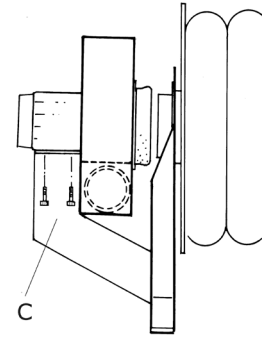

Fig. 4.5.1c Tightening the bolts on the DMF bracket

### 4.5.3 Factory-installed mechanical damper

Based on the facility design requirements, a sealed closing damper will be factory installed on the duct portion of the hose reel. In a facility that includes multiple hose reels, this built-in mechanical damper allows airflow only through the hose reel currently in use, reducing energy costs. The damper opens automatically when the hose is lowered (2 rotations), and closes when the hose is raised by the operator.

This damper is typically used when there are no other dampers installed in the duct work, and no electronic control units are being installed.

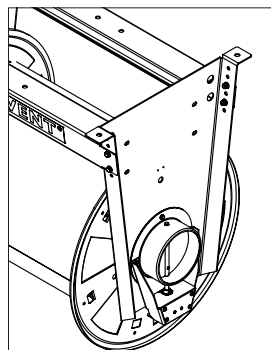

Fig. 4.5.3 Mechanical damper

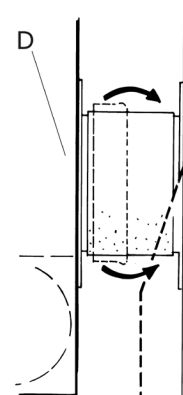

Fig. 4.5.1d Mounting the operating springs on the hose reel drum

## 5 PRESSURE LOSS CALCULATION

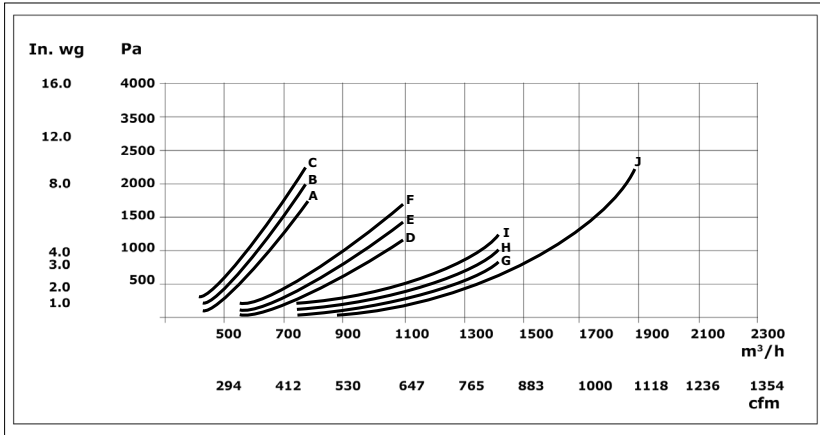

Fig. 5.1 Pressure loss by hose diameter and length

The increase of pressure in a air duct system or in a hose is mainly determined by the air velocity in that system.

The higher the velocity is, the higher the pressure loss will be. And the higher the pressure loss is, the less air the fan will extract. Refer to this manual's Pressure Loss Calculation section for a Pressure Loss Chart to identify a suitable fan regarding the relationship between airflow (m<sup>3</sup>/h) and pressure loss (Pa).

In a ventilation system with many extraction devices and long suction ducts, you can minimize pressure loss by increasing the size of the ducting.

Note: We recommend that the facility's current exhaust temperatures are confirmed to ensure proper hose, fan and airflow selection.

Fig 5.1 shows the pressure loss in the hose reels at different diameters and length. The curves in this chart show the following combinations of hose diameter and hose length. The curves show these combinations of hose reel/hose diameter/hose length:

A	Ø 100 mm (4 in.)	length 7.5 m ( 24,7 ft)
B	Ø 100 mm (4 in.)	length 10 m ( 32,8 ft)
C	Ø 100 mm (4 in.)	length 12.5 m (41,1 ft)
D	Ø 125 mm (5 in.)	length 7.5 m (24,8 ft)
E	Ø 125 mm (5 in.)	length 10 m (32,8 ft)
F	Ø 125 mm (5 in.)	length 12.5 m (41,1 ft)
G	Ø 150 mm (6 in.)	length 7.5 m (24,7 ft)
H	Ø 150 mm (6 in.)	length 10 m (32,8 ft)
I	Ø 150 mm (6 in.)	length 12.5 m (41,1 ft)
J	Ø 200 mm (8 in.)	length 10 m (33 ft)

Note: 75 mm (3 in.) hoses are not available in North America.

## 6 ELECTRICAL DIAGRAM

### MER 230V/460V 3 Phase Wiring

Terminal Strip in MER Control Box

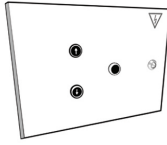

Terminal Strip in MER Junction Box

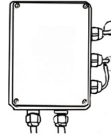

Motor/Limit Switch Wiring

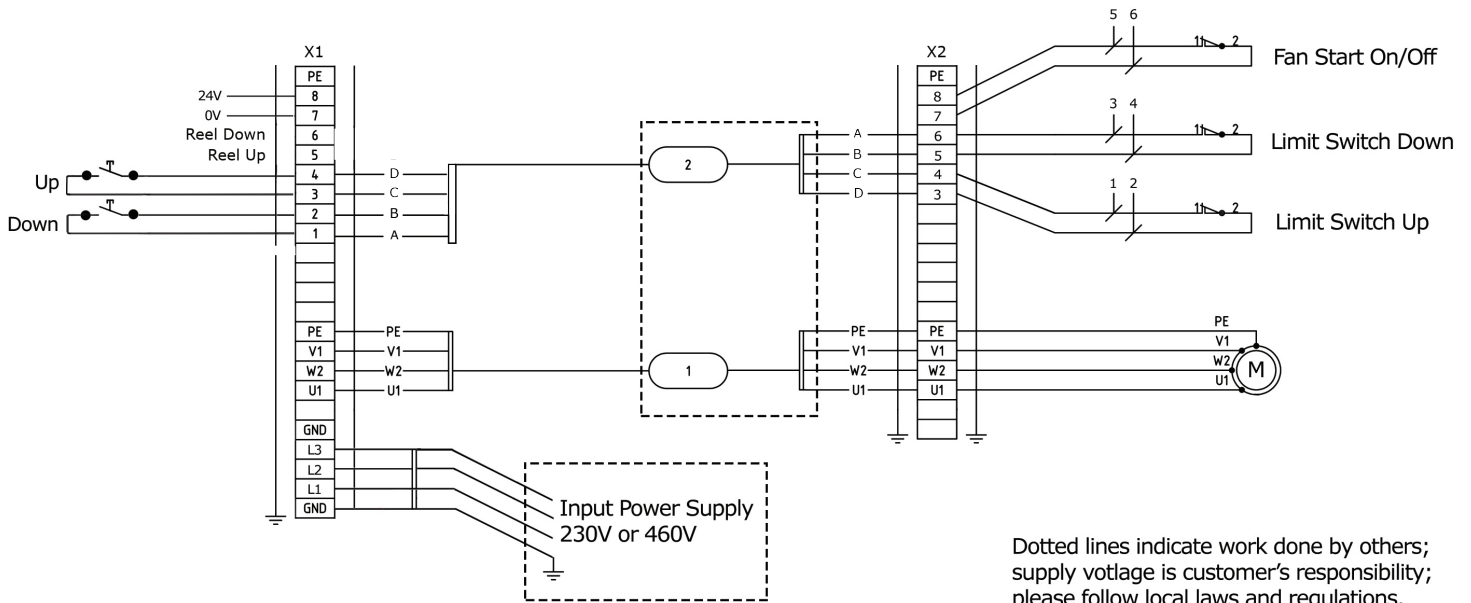
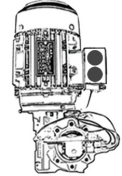

Note: Make sure the transformer in the MER Control Box is wired for 230V or 460V.

Note: For the wiring diagram of electrical diagram above, scan the QR-code below. You can find the wiring diagram of the MER 230V/460V 3 Phase Wiring on page 4 of the PDF file from the QR-code.



Wiring Diagrams: Control Equipment  
MER & MHR Hose Reels in PDF format

## 6 ELECTRICAL DIAGRAM

### MER 120V Single Phase Wiring

Terminal Strip in MER Control Box

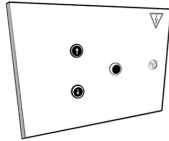

Terminal Strip in MER Junction Box

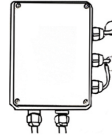

Motor/Limit Switch Wiring

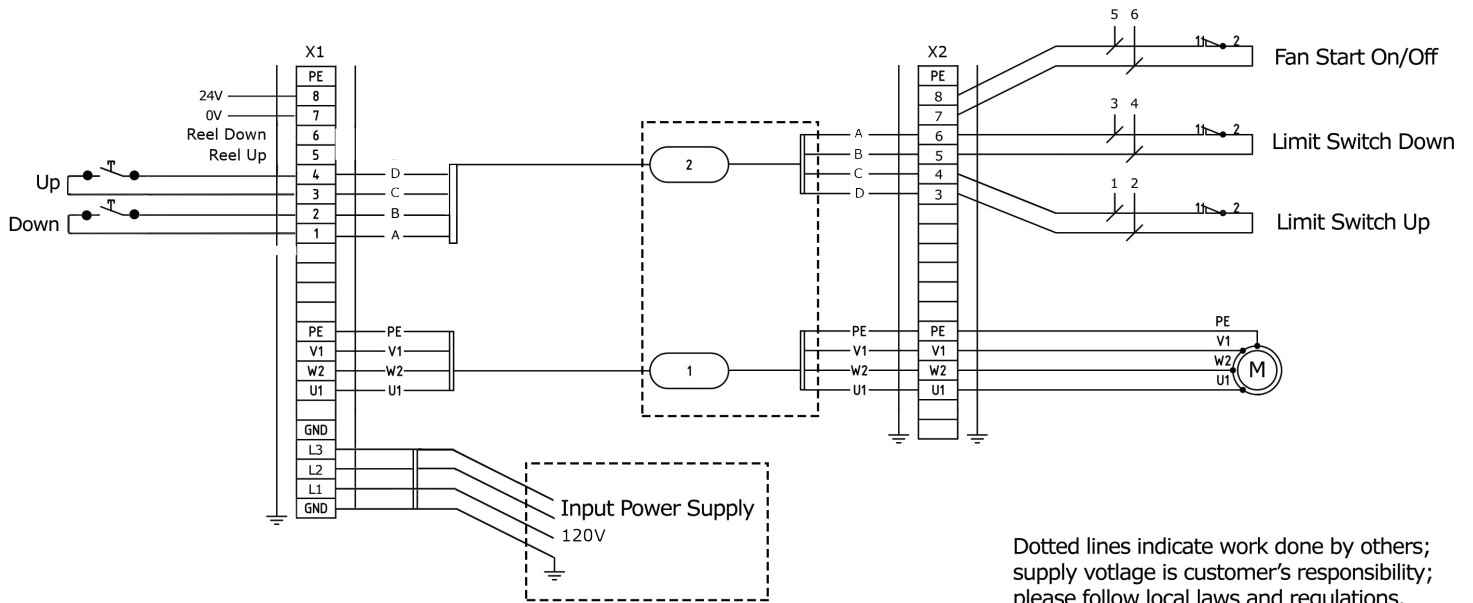
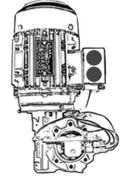

Note: For the wiring diagram of electrical diagram above, scan the QR-code below. You can find the wiring diagram of the MER 120V Single Phase Wiring on page 4 (2-button pendant) and page 6 (4-Button pendant) of the PDF file from the QR-code.

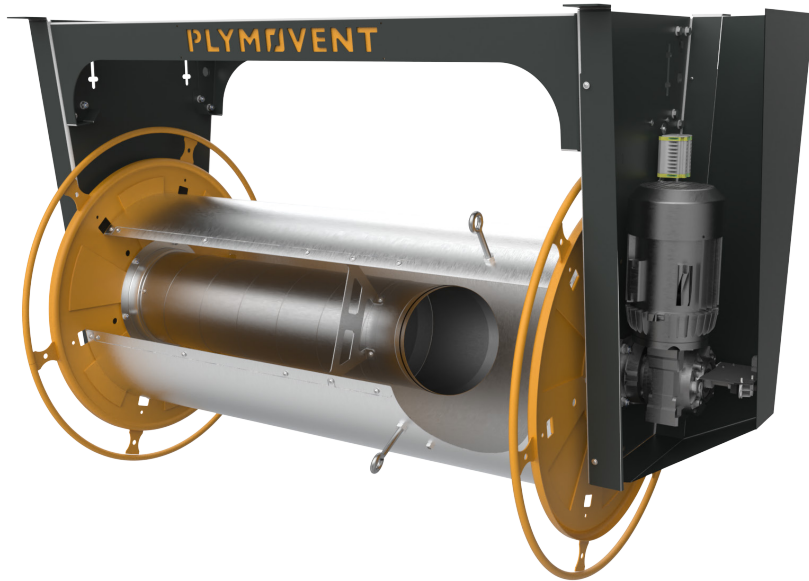

Wiring Diagrams: Control Equipment  
MER & MHR Hose Reels in PDF format

**How to Order Spare Parts:**

At this time, Plymovent is reviewing spare parts for this hose reel. Please contact your authorized distributor to discuss the spart that you need. You can identify your authorized distributor at <https://www.plymovent.com> - click the "Contact Plymovent" link and then click "Sales Offices."

**DECLARATIONS**

CE & UKCA declaration of conformity for machinery

We, Plymovent, Koraalstraat 9, 1812 RK Alkmaar, the Netherlands, herewith declare, on our own responsibility, that the product(s):

- Motorized Exhaust Hose Reel (MER)

which this declaration refers to, is/are in accordance with the conditions of the following Directive:

- CE 2006/42/EU Machine Directive
- UKCA Supply of Machinery (Safety) Regulations 2008

and is/are in conformity with the following harmonized standard(s) and/or other such normative documents + amendments, if any:

EN 12100:2010 Safety of machinery - General principles for design - Risk assessment and risk reduction  
EN 60204-1:2006 Safety of machinery - Electrical equipment of machines

Alkmaar, the Netherlands, December 9<sup>th</sup>, 2022

A handwritten signature in black ink, appearing to read 'Kees Janssen', is written over a light blue horizontal line.

Kees Janssen  
Product Manager EE

**PLYMOVENT**<sup>®</sup>  
clean air at work

