

Environmental diluter system

## MDB-DILUTER PRO



**EN** Installation and user manual

---

---

## TABLE OF CONTENTS

PREFACE.....	2
1 INTRODUCTION.....	2
2 PRODUCT DESCRIPTION .....	3
3 SAFETY INSTRUCTIONS .....	4
4 INSTALLATION .....	6
5 COMMISSIONING .....	19
6 USE .....	20
7 MAINTENANCE .....	21
8 TROUBLESHOOTING .....	23
9 SPARE PARTS .....	24
10 ELECTRICAL DIAGRAM .....	24
11 DISPOSAL.....	24
CE DECLARATION.....	25

### EN | ORIGINAL INSTRUCTION

All rights reserved. The information given in this document has been collected for the general convenience of our clients. It has been based on general data pertaining to construction material properties and working methods known to us at the time of issue of the document and is therefore subject at any time to change or amendment and the right to change or amend is hereby expressly reserved. The instructions in this publication only serve as a guideline for installation, use, maintenance and repair of the product mentioned on the cover page of this document. This publication is to be used for the standard model of the product of the type given on the cover page. Thus the manufacturer cannot be held responsible for any damage resulting from the application of this publication to the version actually delivered to you. This publication has been written with great care. However, the manufacturer cannot be held responsible, either for any errors occurring in this publication or for their consequences.

*To improve comprehension for people whose first language is not English, we have written parts of this manual in Simplified Technical English (STE). STE is a controlled language originally developed for aerospace industry maintenance manuals. It offers a carefully limited and standardized subset of English, along with specific writing rules.*









## PREFACE

### Using this manual

This manual is intended to be used as a work of reference for professional, well trained and authorised users to be able to safely install, use, maintain and repair the product mentioned on the cover of this document.

### Pictograms and symbols

The following pictograms and symbols are used in this manual:

	<b>TIP</b> Suggestions and recommendations to simplify carrying out tasks and actions.
	<b>ATTENTION</b> A remark with additional information for the user. A remark brings possible problems to the user's attention.
	<b>CAUTION</b> Procedures, if not carried out with the necessary caution, could damage the product, the workshop or the environment.
	<b>WARNING</b> Procedures which, if not carried out with the necessary caution, may damage the product or cause serious personal injury.
	<b>CAUTION</b> Denotes risk of electric shock.
	<b>WARNING!</b> Fire hazard! Important warning to prevent fire.
	<b>Personal protective equipment (PPE)</b> Instruction to use respiratory protection when you do service, maintenance and repair jobs, as well as during functional testing. We recommend to use a half-face respirator according to EN 149:2001 + A1:2009, class FFP3 (Directive 89/686/EEC).
	<b>Personal protective equipment (PPE)</b> Instruction to use protective gloves when you do service, maintenance and repair jobs.

### Text indicators

Listings indicated by "-" (hyphen) concern enumerations.  
Listings indicated by "•" (bullet point) describe steps to perform.

### Product indications / Abbreviations

<u>Product type:</u>	<u>Equals to:</u>
- ControlPro/Panel	Panel
- ControlPro/HMI	HMI
- MDB-Diluter PRO	MDB-Diluter

## 1 INTRODUCTION

### 1.1 Identification of the product

The product consists of various components, the identification plates of which contain the following data:

- product name
- serial number
- supply voltage and frequency
- power consumption



### 1.2 General description

#### 1.2.1 Filter system

The MDB-Diluter is a free-standing general filtration system

that prevents accumulation of welding fume by continuous filtration of polluted air. It consists of a central filter system with 8 filter cartridges, a fan in sound-absorbing case, an outlet unit with adjustable outlet nozzles, a silencer and control equipment.

#### 1.2.2 Control equipment

The MDB-Diluter is supplied with the ControlPro, which is an intelligent control panel with an integrated frequency inverter and a separate HMI<sup>1</sup>. This system controls the fan and the filter cleaning system based on compressed air.

### 1.3 System overview

Fig. 1.1

- A Filter system (type MDB-Diluter)
- B HMI
- C Panel [control panel]
- D Extraction fan (type SIF-1200)

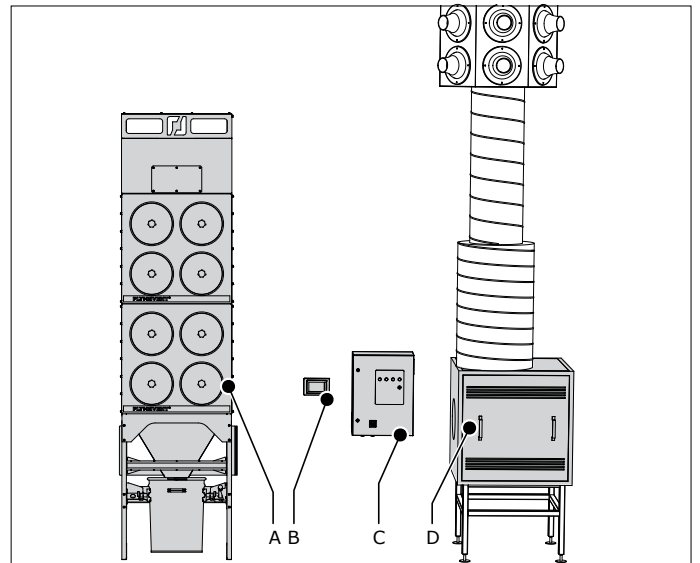

Fig. 1.1 MDB-Diluter PRO

### 1.4 Options and accessories

The following products are available as an option and/or accessory:

- CAR-KIT<sup>2</sup> | Compressed air regulator with pressure gauge
- Panel → HMI cable 30 or 60 m (98 or 197 ft), instead of standard length 15 m (49 ft)
- LightTower
- BoosterFan | Additional fan to increase the airflow

### 1.5 Technical specifications

#### 1.5.1 MDB-Diluter (filter system)

Dimensions	refer to Fig. I on page 26
Filter material	BiCo spunbond polyester + PTFE membrane
Filter surface area	8 x 15 m <sup>2</sup> = 120 m <sup>2</sup> (8 x 161 ft <sup>2</sup> = 1288 ft <sup>2</sup> )
Welding fume class	W3 compliant (EN-ISO 15012-1:2013)
Required compressed air quality	dry and oil-free according to ISO 8573-3 class 6
Required pressure	4-5 bar (60-75 psi)
Compressed air connection	push-in fitting: - in: G 3/8 in. - out: 12 mm
Compressed air consumption	40-50 nl/pulse (1.4-1.8 ft <sup>3</sup> /pulse)

1. Human Machine Interface
2. Recommended option to control the compressed air supply

Max. airflow: - unrestricted - operational	12.000 m <sup>3</sup> /h (7,063 CFM) 9.000 m <sup>3</sup> /h (5,297 CFM)
Power consumption fan	7,5 kW (10 HP)
Connection voltage	400-690V/3~/50Hz 480V/3~/60Hz 600V/3~/60Hz
Insulation class fan	F with PTC
Protection class	IP 54
Weight (net)	

### 1.5.2 ControlPro (control equipment)

#### Panel

Dimensions	refer to Fig. II on page 26
Weight	55 kg (121 lbs)
Material of housing	sheet metal
Protection class	IP 54
Input voltage	400V3ph/50Hz   480V/3ph/60Hz   600V/3ph/60Hz
Internal operating voltage	24 VDC (controls)   115V / 230V (cooling fan)
Power consumption	max. 7,5 kW
Internal pressure sensors	2x integrated pressure sensor (for filter pressure and fan pressure)
Approvals & certificates	400V: CE   480V / 600V: cULus (UL 508A)

#### HMI

Dimensions	255 x 165 x 125 mm (10.0 x 6.5 x 4.9 in.)
Weight	900 g (2 lbs.)
Material of housing	PC/ABS
- flammability standard	- UL94 V-0
Operating voltage	24 VDC (+/- 15%)
Power consumption	- display off: nom. 4 W - display on: max. 5 W
External connectors	- CAN + power (connection to Panel) [M12-5p shielded connector] - USB 2.0 (host only) [USB A receptacle, with dust cap] - ethernet 10/100 Mbit/s [RJ45, shielded, with dust cap]
Display:	
- size	- 7"
- type	- resistive touch screen
- brightness	- 300 cd/m <sup>2</sup>
- colour	- 262K
- resolution	- 800 x 480 pixels
Approvals & certificates	CE

### 1.6 Ambient conditions

#### 1.6.1 MDB-Diluter (filter system)

Operating temperature:	
- min.	+5°C (41°F)
- nom.	+20°C (68°F)
- max.	+70°C (158°F)
Max. relative humidity	90%
Suitable for outdoor use	no

#### 1.6.2 ControlPro (control equipment)

#### Panel

Ambient temperature:	Pressure sensors:	
- min.	internal	external (option)
- nom.	0°C (32°F)	-20°C (-4°F)
- max.	+20°C (68°F)	+20°C (68°F)
	+50°C (122°F)	+50°C (122°F)
Max. relative humidity	80%	
Suitable for outdoor use	no	

#### HMI

Ambient temperature:	
- min.	0°C (32°F)
- nom.	+20°C (68°F)
- max.	+50°C (122°F)
Max. relative humidity	80%
Suitable for outdoor use	no

## 2 PRODUCT DESCRIPTION

### 2.1 Components

The product consists of the following main components and elements:

#### 2.1.1 MDB-Diluter

Fig. 2.1

- A Outlet unit with 6 adjustable outlet nozzles
- B Vertical duct 1,5 m / Ø 500 mm (5 ft / Ø 19.7 in.)
- C Silencer
- D Extraction fan (SIF-1200) in sound absorbing case
- E Panel (control panel incl. frequency inverter)
- F HMI
- G Fan frame
- H Dustbin
- I Mounting frame
- J Filter module (2)
- K Air inlet module with inspection covers
- L Filter cartridge CART-PTFE/15 (8)

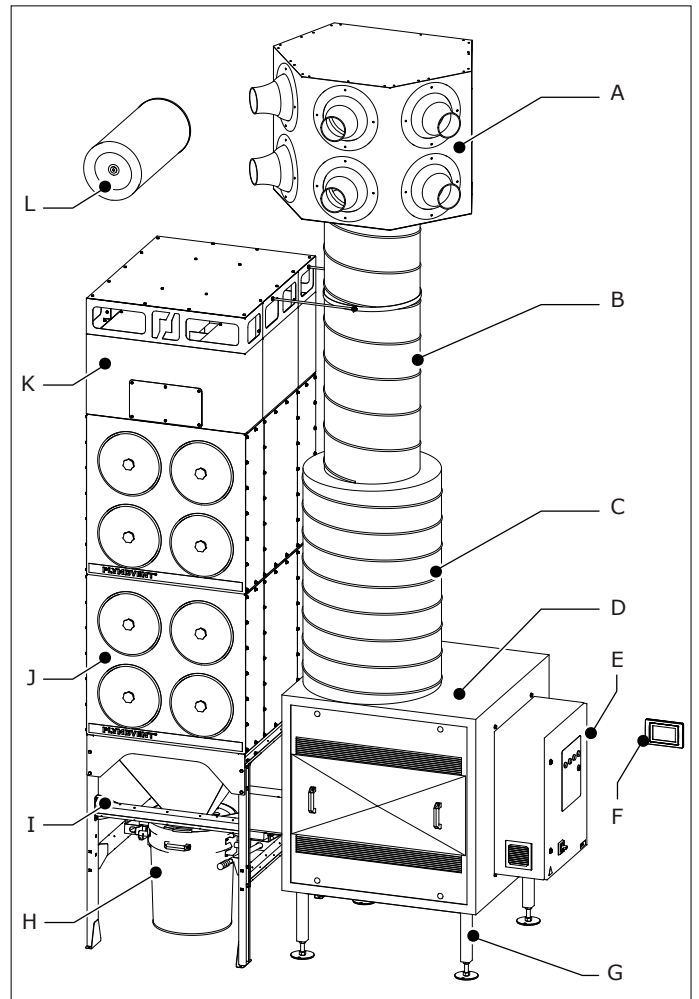

Fig. 2.1 Main components and elements

## 2.1.2 Control equipment

### Panel

Fig. 2.1

#### High voltage compartment

- A VFD (frequency inverter)
- B Transformer
- C Cooling fan
- D Thermostat
- E Switch mode power supply
- F Circuit protectors<sup>3</sup>
- G Main switch (interior parts)

#### Low voltage compartment

- H PC board
- I Manual controls

#### Outside

- J Status panel
- K Main switch (exterior parts)

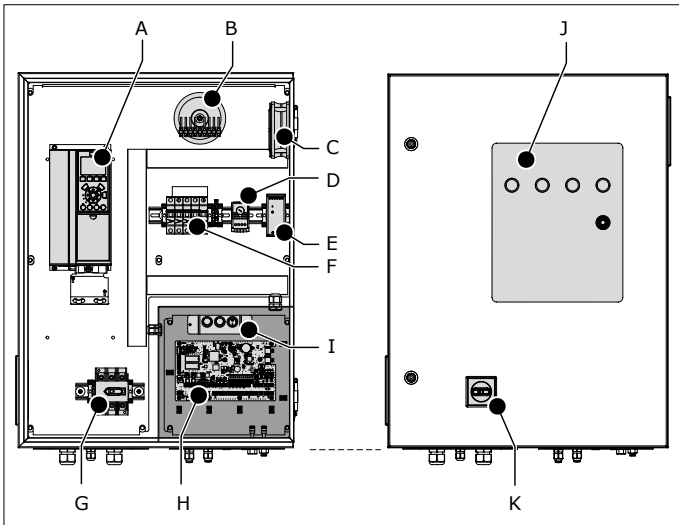

Fig. 2.1 Main components Panel

### HMI

Fig. 2.2

- A Touch screen
- B Mounting bracket

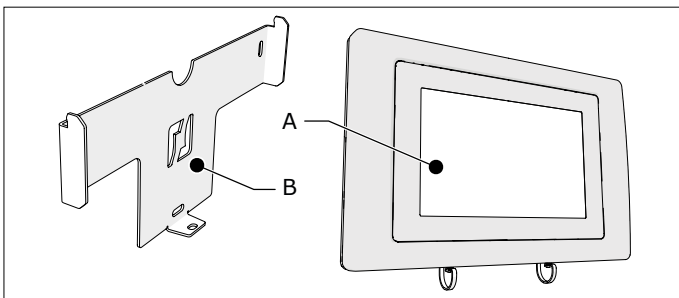

Fig. 2.2 Main components HMI

### Connection cables

- Panel → HMI cable
- motor cable
- PTC cable
- control cable (connected to the compressed air switch)

## 2.2 Operation

### 2.2.1 MDB-Diluter

The air -that contains welding fume- is extracted through the air inlet module on top of the unit. The larger particles and any sparks are separated by a labyrinth-shaped<sup>4</sup> spark arrester. Subsequently the air is cleaned by the eight filter cartridges. The air then passes the extraction fan and a duct silencer. The clean air is blown back into the workshop by the outlet unit with adjustable nozzles.

The filter cartridges are cleaned individually from the inside out by compressed air pulses. This filter cleaning system is called the RamAir™ pulse amplifier. The dust and dirt particles are collected in the dustbin. The fan speed is pressure controlled.

Apart from air cleaning, the system optimises the present natural ventilation (draught) and/or forced ventilation (roof/ wall fans) system and equally distributes the present welding fume to reduce the background concentration of welding fume in the workshop.

### 2.2.2 ControlPro

ControlPro is an intelligent platform that controls the filter system as well as the connected extraction fan. It contains an extensive feature package to monitor and arrange the RamAir™ pulse amplifier (filter cleaning system), the required airflow and the corresponding fan speed. By means of the user-friendly HMI you can program all desired parameters. The HMI gives a clear insight into the system status and performance at all times. ControlPro allows for remote access via a network connection.

## 3 SAFETY INSTRUCTIONS

### General

The manufacturer does not accept any liability for damage to the product or personal injury caused by ignoring of the safety instructions in this manual, or by negligence during installation, use, maintenance, and repair of the product mentioned on the cover of this document and any corresponding accessories. Specific working conditions or used accessories may require additional safety instructions. Immediately contact your supplier if you detect a potential danger when using the product.



**The user of the product is always fully responsible for observing the local safety instructions and regulations. Obey all applicable safety instructions and regulations.**

### User manual

- Everyone working on or with the product, must be familiar with the contents of this manual and must strictly obey the instructions therein. The management should instruct the personnel in accordance with the manual and obey all instructions and directions given.
- Do not change the order of the steps to perform.
- Always keep the manual with the product.

### Pictograms and instructions on the product (if present)

- The pictograms, warning and instructions attached to the product are part of the safety features. They must not be covered or removed and must be present and legible during the entire life of the product.
- Immediately replace or repair damaged or illegible pictograms, warnings and instructions.

3. CE (400V): circuit breakers | UL (480/600V): fuses

4. Refer to Fig. VI on page 28 for the airflow through the air inlet module

## Users

- The use of this product is exclusively reserved to authorised, trained and qualified users. Temporary personnel and personnel in training can only use the product under supervision and responsibility of skilled engineers.
- Stay alert and keep your attention to your work. Do not use the product when you are under the influence of drugs, alcohol or medicine.
- The product is not to be used by children or persons with reduced physical, sensory or mental capabilities, or lack of experience and knowledge, unless they have been given supervision or instruction.
- Children must be supervised not to play with the product.

## Intended use<sup>5</sup>

The MDB-Diluter has been designed exclusively for extracting and filtering gases and particles which are released during the most common welding processes.

The ControlPro has been designed exclusively as control equipment for use with a filter system type MDB-Diluter of Plymovent including the connected extraction fan.

Using the product for other purposes is considered contrary to its intended use. The manufacturer accepts no liability for any damage or injury resulting from such use. The product has been built in accordance with state-of-the-art standards and recognised safety regulations. Only use this product when in technically perfect condition in accordance with its intended use and the instructions explained in the user manual.

## Technical specifications



The specifications given in this manual must not be altered.

## Modifications

Modification of (parts of) the product is not allowed.

## Product combinations

If the product is used in combination with other products or machines, the safety instructions in the documentation of these products also apply.

	<b>WARNING!</b> Fire hazard! Do <b>not</b> use the product for: <ul style="list-style-type: none"><li>- extracting and/or filtering flammable, glowing or burning particles or solids or liquids</li><li>- extracting and/or filtering of aggressive fumes (such as hydrochloric acid) or sharp particles</li><li>- extracting and/or filtering dust particles which are released when welding surfaces treated with primer</li><li>- sucking cigarettes, cigars, oiled tissues, and other burning particles, objects, and acids</li></ul>
	<b>WARNING</b> Do <b>not</b> use the product for: <ul style="list-style-type: none"><li>- oil mist</li><li>- paint mist</li><li>- extraction of hot gases (more than 45°C/113°F continuously)</li><li>- explosive environments or explosive substances/gases</li></ul> <i>Note: this list is not all-embracing.</i>

5. "Intended use" as explained in EN-ISO 12100-1 is the use for which the technical product is suited as specified by the manufacturer, inclusive of his directions in the sales brochure. In case of doubt it is the use which can be deduced from the construction, the model and the function of the technical product which is considered normal use. Operating the machine within the limits of its intended use also involves observing the instructions in the user manual.

## Installation

- The installation of this product is exclusively reserved to authorised, trained and qualified engineers.
- Electric connection to be executed in accordance with local requirements. Ensure compliance with the EMC regulatory arrangements.
- During installation, always use Personal Protective Equipment (PPE) to avoid injury. This also applies for persons who enter the work area during installation.
- Use sufficient climbing gear and safety guards when working on a higher level than 2 meter (6.5 ft) (local restrictions may apply).
- Do not install the product in front of entrances and exits which must be used for emergency services.
- Mind any gas and water pipes and electric cables.
- Make sure that the wall, ceiling or support system are strong enough to carry the product.
- Ensure the workspace is well illuminated.
- Use common sense. Stay alert and keep your attention to your work. Do not install the product when you are under the influence of drugs, alcohol or medicine.
- Make sure that the workshop, in the vicinity of the product, contains sufficient approved fire extinguishers (suitable for fire classes ABC).
- Air containing particles such as chromium, nickel, beryllium, cadmium, lead etc., which is a health hazard, should never be recycled. This air must always be brought outside the working area.

## Use

- Inspect the product and check it for damage. Verify the functioning of the safety features.
- During use, always use Personal Protective Equipment (PPE) to avoid injury. This also applies for persons who enter the work area.
- Check the working environment. Do not allow unauthorised persons to enter the working environment.
- Protect the product against water and humidity.
- Make sure the room is always sufficiently ventilated; this applies especially to confined spaces.



## Service, maintenance and repairs

- Obey the maintenance intervals given in this manual. Overdue maintenance can lead to high costs for repair and revisions and can render the guarantee null and void.
- During service, maintenance and repair jobs, always use Personal Protective Equipment (PPE) to avoid injury. This also applies for persons who enter the work area.
- Always use tools, materials, lubricants and service techniques which have been approved by the manufacturer. Do not use worn tools and do not leave any tools in or on the product.
- Safety features which have been removed for service, maintenance or repairs, must be put back immediately after finishing these jobs and it must be checked that they still function properly.
- Use sufficient climbing gear and safety guards when working on a higher level than 2 meter (6.5 ft) (local restrictions may apply).



## ATTENTION

Service, maintenance and repairs should only be performed in accordance with directive TRGS 560 by authorised, qualified and trained persons (skilled) using appropriate work practices.

	<p><b>WARNING</b></p> <p>Before you carry out service, maintenance and/or repair jobs:</p> <ul style="list-style-type: none"> <li>- fully disconnect the machine from the mains</li> <li>- disconnect compressed air supply</li> </ul>
	<p><b>WARNING</b></p> <p><b>Always</b> wear face mask and gloves during filter exchange/cleaning.</p> <p>Industrial vacuum cleaner used during service and maintenance should meet dust class H according to EN 60335-2-69.</p>

- Bolt M8x20 (9)
- Washer M8 (9)
- Compressed air switch (incl. control cable #20)

#### Extraction fan

- Fan
- Fan mounting frame

#### Inside the fan housing:

- Cable glands
- Electric connection material

#### Outlet unit

- Silencer
- Duct connector Ø 500 mm (19.7 in.) with KEN-LOK sealing (2)
- Duct 1,5 m Ø 500 mm (5 ft Ø 19.7 in.)
- Outlet unit with nozzles
- Support bracket (two-piece)
- Threaded rod M10 (2)
- Nut M10 (8)

#### ControlPro | Control equipment

- Panel (control panel), incl. double-bit key, mounting brackets (4) and mounting material
- HMI, incl. bracket, locking screw and ethernet field connector (IP 67)

#### Connection cables

- Motor cable: 4-cored shielded cable 4 mm<sup>2</sup> (AWG 12)
- PTC cable: 2-cored shielded cable 0,75 mm<sup>2</sup> (AWG 18)
- Panel to HMI cable, incl. heat shrinking tubes
- Pneumatic hoses, incl. mounting material:
  - 2x10 m (for filter pressure)
  - 10+1 m (for fan pressure)
- Electrical diagram



If parts are missing or damaged, contact your supplier.

#### 4.3 Positioning

You can install the MDB-Diluter on the floor or on a platform. Make sure that the outlet nozzles can be directed to the welding fume layer without obstruction.

Depending on the circumstances, it might be necessary to use a longer or shorter duct than the 1,5 m (5 ft) one which is standard supplied.

- Refer to Fig. III on page 27 for positioning examples.

#### 4.4 Mounting of the filter system

To install the filter system, do the following.

##### 4.4.1 Mounting frame (MDB-FRAME)

Fig. 4.1

- Assemble the mounting frame<sup>9</sup> with the bolts M8x16 (A) and washers (B). Tighten the bolts *loosely*.



## 4 INSTALLATION

### 4.1 Tools and requirements

You need the following tools to install the system:

- lifting equipment (e.g. fork-lift truck, crane)
- climbing gear (e.g. scissor lift)
- cordless drill
- wrench (metric sizes 10-13-17)
- screw driver
- level
- mains cable 4 mm<sup>2</sup> (AWG 12); 3 cores + mass
- self-tapping screws
- duct tape
- flowmeter
- basic tools
- tools for electrical connections<sup>6</sup>



#### 4.1.1 To be sourced locally

Mounting material<sup>7</sup>:

- to install the Panel to the fan housing or to the wall (hardware max. Ø 10 mm)
- to install the HMI to the wall (head height of screws max. 6 mm, Ø max. 4 mm)



Connection cables<sup>8</sup>:

- refer to Table I on page 32 for the cable specifications

If necessary:

- additional cable glands M16

Optional (for remote access to HMI via network):

- ethernet cable, min. CAT 5E shielded

### 4.2 Unpacking

Check that the product is complete. The package contains:



#### MDB-Diluter | Filter system

##### Filter system

- MDB-FRAME | Mounting frame
- MDB-BM/4 | Filter module (2)
- CART-PTFE/15 | Filter cartridge (8)
- Air inlet module
- MDB-HOPPER/80 | Hopper
- MDB-OUTLET/400 | Outlet Ø 400 mm
- DB-80 | Dustbin 80 litres
- MDB-JOIN KIT | Connection material
- MDB-COVER/S | Cover plate (8)
- MDB-COVER/M | Cover plate (4)
- Screw set (2)
- Seal set MDB-BM/4 (3)
- Spare seal set MDB
- SealApplicator

6. E.g. heat gun, cable stripping tool

7. The type of mounting material depends on the wall type

8. Number and type of cables depend on the selected options

9. Note: the "open" sides of the bars are on the outside

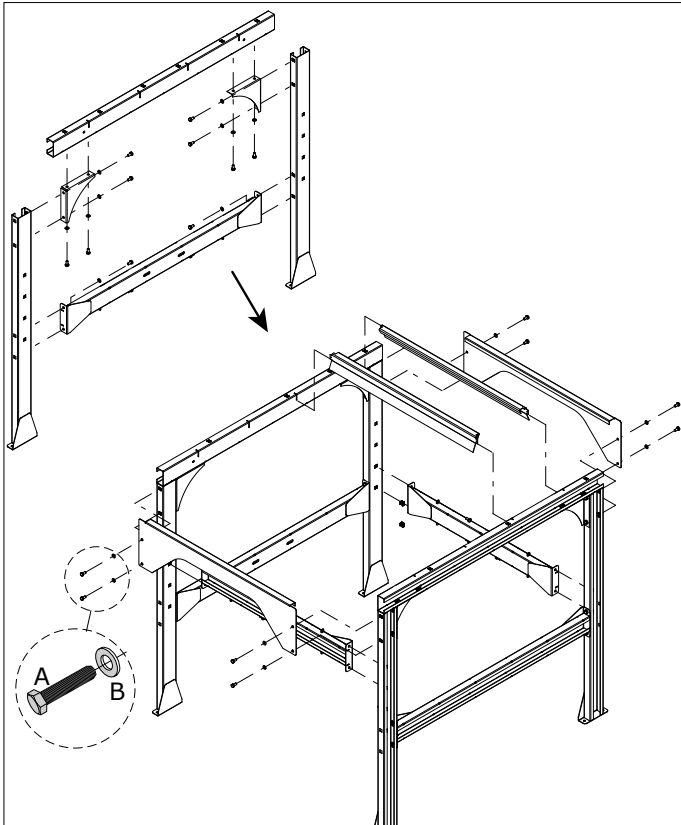

Fig. 4.1 Assembly of the mounting frame

#### 4.4.2 Air outlet module and hopper

You must install the air outlet module (MDB-OUTLET/400) behind the hopper (MDB-HOPPER) on the mounting frame.

To install the air outlet module, do the following.

##### Air outlet module (MDB-OUTLET)

Fig. 4.2

- Drill a  $\varnothing 9$  mm (0.25 in.) hole in the two notches (A) of the outlet module.

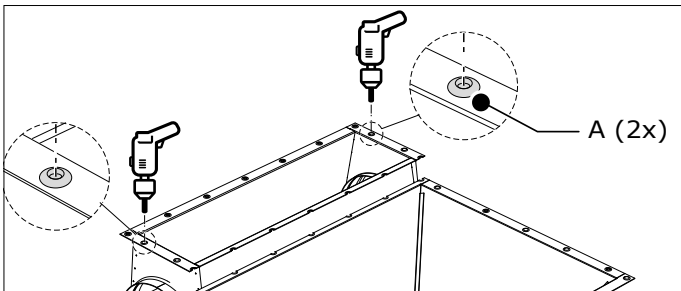

Fig. 4.2 Air outlet module

Fig. 4.3

- Temporary disassemble the back side of the frame to put the outlet module on the frame.

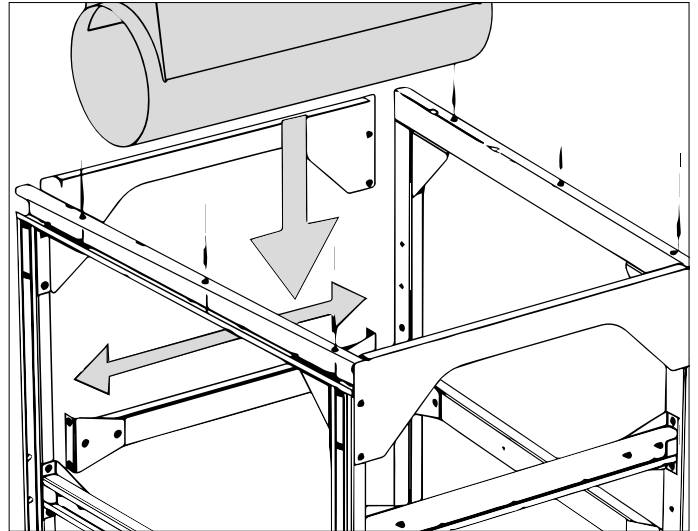

Fig. 4.3 Air outlet module on frame

Fig. 4.4

- Slightly lift the outlet module and put the support profiles (A) in the slits (B).

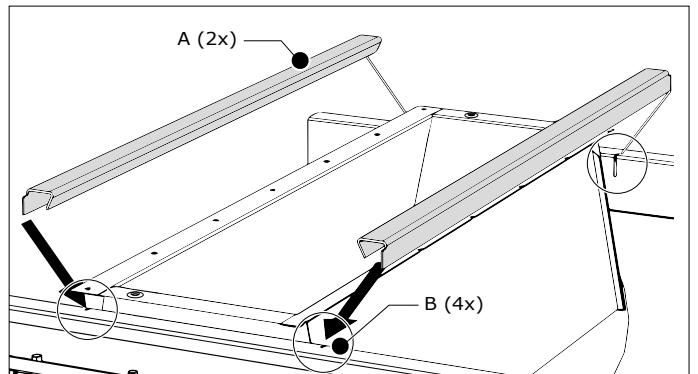

Fig. 4.4 Support profiles

Fig. 4.5

##### Hopper (MDB-HOPPER)

- Put the hopper (A) on the frame.

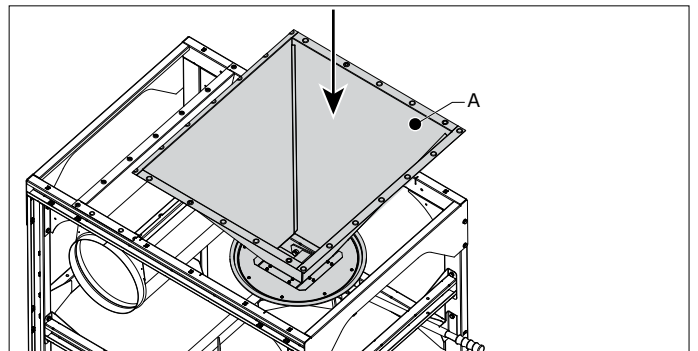

Fig. 4.5 Hopper on frame

##### Fastening

- Tighten the bolts of the entire frame (refer to Fig. 4.1).

Fig. 4.6

##### Dustbin lift

- Install the dustbin lift (B) to the frame. Put the bolts M10x40 (A) from the inside into the slotted holes<sup>10</sup>.

10. No nuts involved. The dustbin lift has some tolerance



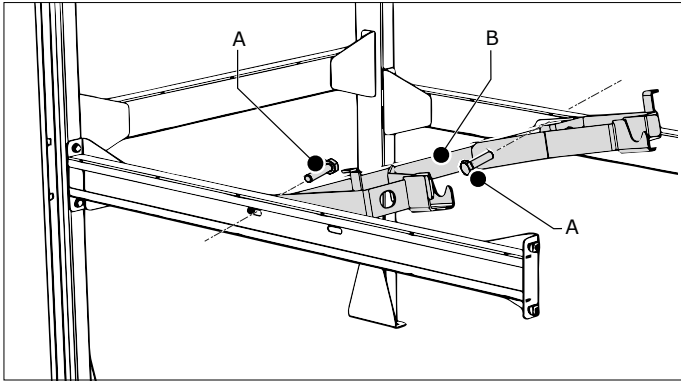

Fig. 4.6 Dustbin lift

Fig. 4.7

- Install the locking device (A) with 2 washers and 2 bolts.

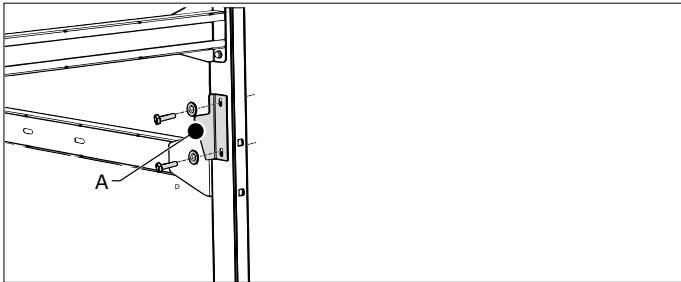

Fig. 4.7 Locking device

Fig. 4.8

- Put the lifting pin (B) through the holes and attach it with 2 cotter pins (A).
- Put the extension pin with handle (C) into the lifting pin.

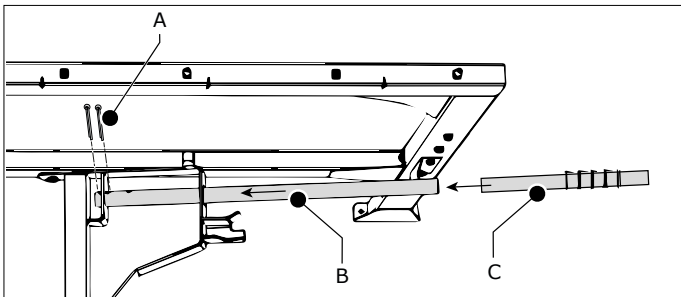

Fig. 4.8 Lifting pin

Fig. 4.9

### Sealing (MDB seal assembly set)

These specially constructed seals between the frame, the individual filter modules, the outlet module and the cover plates are necessary to make the entire MDB-Diluter system airtight.

	How to apply the seals:	How to use SealApplicator:

- Remove dust, if any, from the upper frame.
- Lay the seals loosely on the frame and put them together<sup>11</sup>.
- Make sure that the jigsaws tightly fit.

11. Do not worry about a slight misalignment of the seal holes

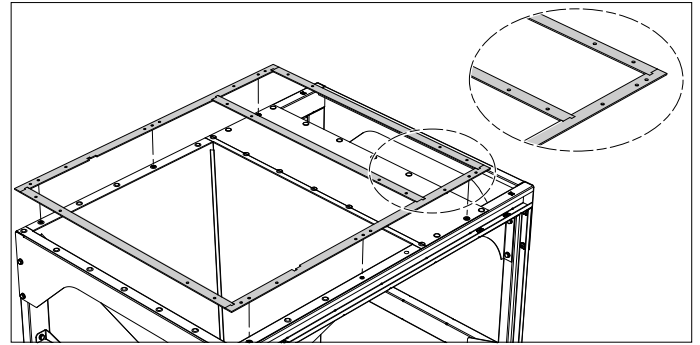

Fig. 4.9 Seals on frame

One strip 846 mm (33.3 in.) is redundant.

Fig. 4.10

	<ul style="list-style-type: none"> <li>• Start with a <b>long</b> seal (1046 mm).</li> <li>• Try to avoid touching the sticky side with your fingers.</li> <li>• Make sure that you attach the seal in the <b>centre</b> of the frame edges and that the jigsaws fit together.</li> </ul>
--	---

- Peel approx. 50 mm of the backing material (A) and stick the seal on the frame. Draw the backing material to the *inside* of the frame.
- Continue to peel and stick the seal in steps of approx. 50 mm according to the indicated sequence (B).

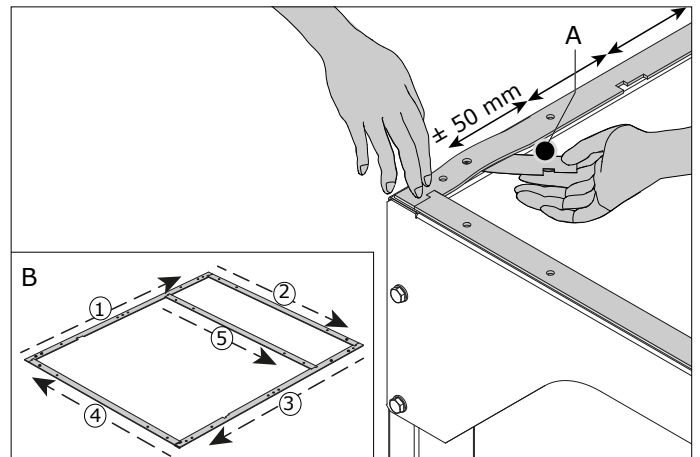

Fig. 4.10 Removal of backing material

### 4.5 Filter modules (MDB-BM/4)

The MDB-Diluter contains two filter modules on top of each other. The *top* and *right* side of each filter module are already provided with seals. You must provide the *left* side of the filter modules with additional seals.

To put additional seals on the left side of the filter modules, do the following.

Fig. 4.11

- Remove the cardboard box and the plastic bag from the first filter module<sup>12</sup>.
- Lift and turn the filter module 90° in its original packing<sup>13</sup>.

12. Leave the filter module on the pallet to avoid damage

13. Do **not** shift the filter module to avoid damage to the seals and backing material

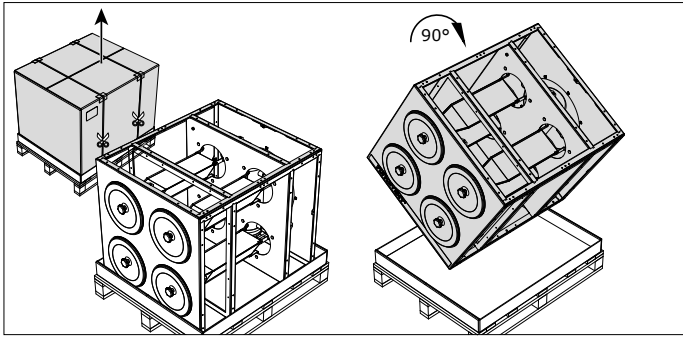

Fig. 4.11 Unpacking

Fig. 4.12

- Remove dust, if any, from the edge surfaces of the filter module.
- Lay the seals loosely on the filter module and put them together<sup>14</sup>.
- Make sure that the jigsaws tightly fit.

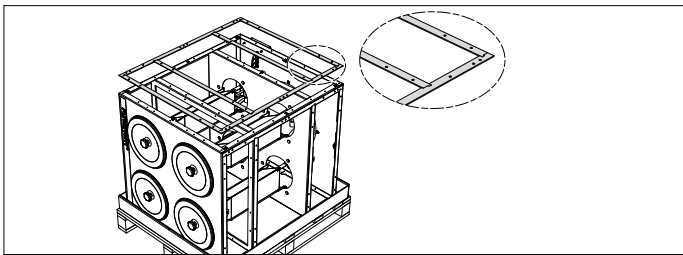

Fig. 4.12 Seals on filter module

Fig. 4.13

- Start with a **long** seal (1046 mm).
- Try to avoid touching the sticky side with your fingers.
- Make sure that you attach the seal in the **centre** of the edges and that the jigsaws fit together.

- Peel approx. 50 mm of the backing material (A) and stick the seal on the filter module. Draw the backing material to the *inside* of the filter module.
- Continue to peel and stick the seal in steps of approx. 50 mm according to the sequence below.

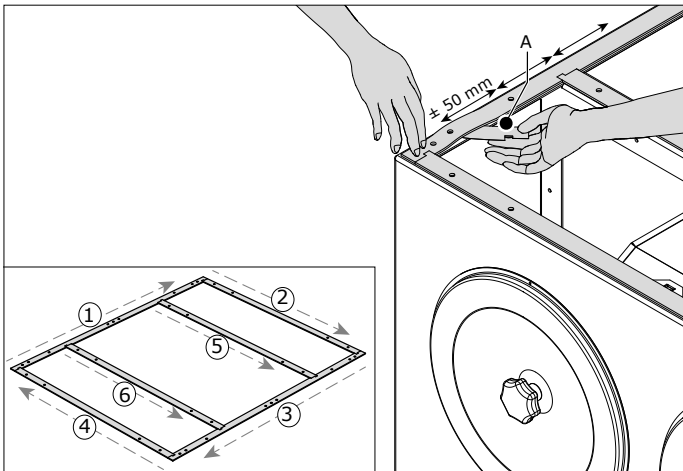

Fig. 4.13 Removal of backing material

Fig. 4.14

- Lift and turn the filter module back to its original position.
- Repeat the procedure for the other filter module.

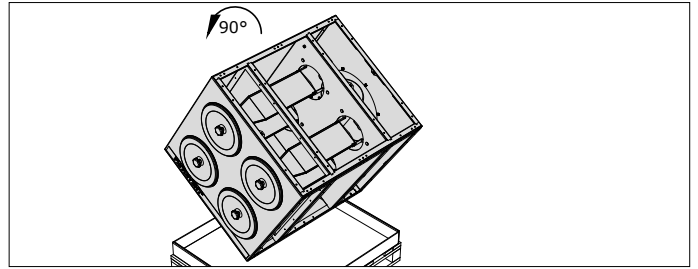

Fig. 4.14 Turning back

- To replace a damaged or incorrectly applied seal, do the following.
  - Remove the damaged or incorrectly applied seal.
  - Preferably: remove the remains of glue, if any, from the filter module (e.g. with sticker remover). Make sure that you do not damage the undamaged seals.
  - Apply a spare seal according to the above instructions.



**ATTENTION**

**General installation instructions**

- Remove the backing material **before** you put the pointed positioning studs on the frame and filter module. Try to avoid touching the sticky seals with your fingers.
- Always use SealApplicator lubricant on the sealing material before you connect any component of the MDB-Diluter system<sup>15</sup>. By the use of SealApplicator you can slightly shift the filter module to get the right position. After approx. 60 seconds the lubricant is dry so you cannot shift anymore.
- Install one filter module at a time. After spraying, immediately position the filter module or any other component<sup>16</sup>.

**Vertical connection of filter modules**

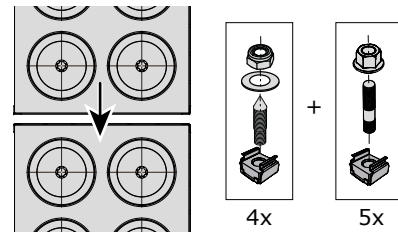

- Remove the filter lids and the round cover plates on the back to have an easier access to the inside of the filter modules for connection purposes.

**4.5.1 Filter module on frame**

Fig. 4.15

- Put the MDB-FRAME (A) in fully horizontal position.

14. Do not worry about a slight misalignment of the seal holes

15. The seals are extremely adhesive; without the use of SealApplicator, components might stick together in the wrong position and cannot be disconnected without damage.

16. After approx. 60 seconds SealApplicator lubricant loses its functions and you cannot shift anymore

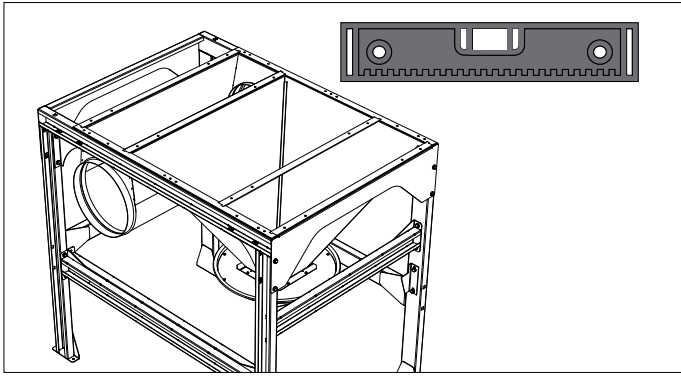

Fig. 4.15 Frame in horizontal position

Fig. 4.16

- (1) Remove the backing material of the seals.
- (2) Put 4 positioning studs in the upper cage nuts of the mounting frame (corner positions).
- (3) Spray SealApplicator lubricant on the seals.
- (4) Put the filter module **within 60 seconds** on the frame.
- (5) Put a washer + locknut on the positioning studs and tighten them.

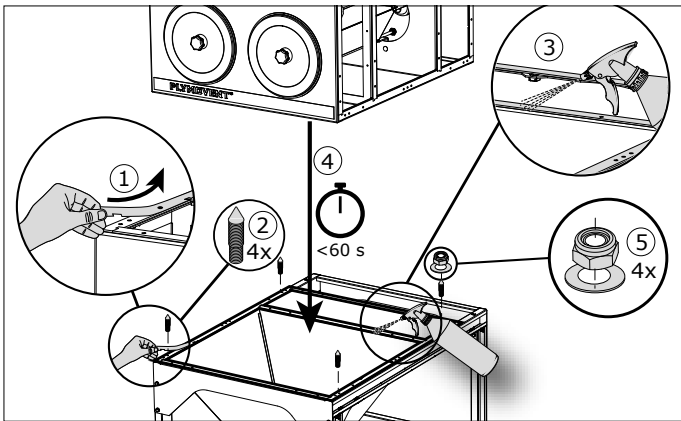

Fig. 4.16 Filter module on frame

Fig. 4.17

- Put studs in the remaining 2 cage nuts and tighten them with a flange nut (B).

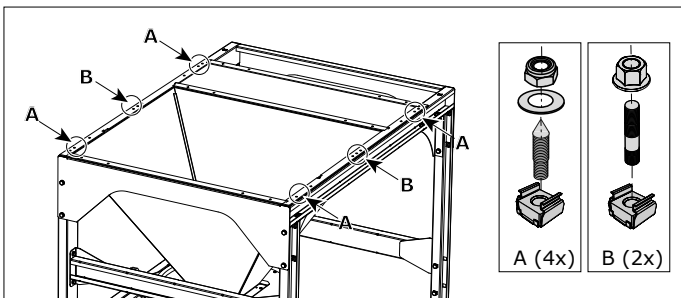

Fig. 4.17 Position of studs

Fig. 4.18

- (1) Remove the backing material of the seals.
- (2) Put 4 positioning studs in the upper cage nuts of the first filter module (corner positions).
- (3) Spray SealApplicator lubricant on the seals.
- (4) Put another filter module (A) **within 60 seconds** on the previous one.
- (5) Put a washer + locknut (B) on the positioning studs and tighten them.

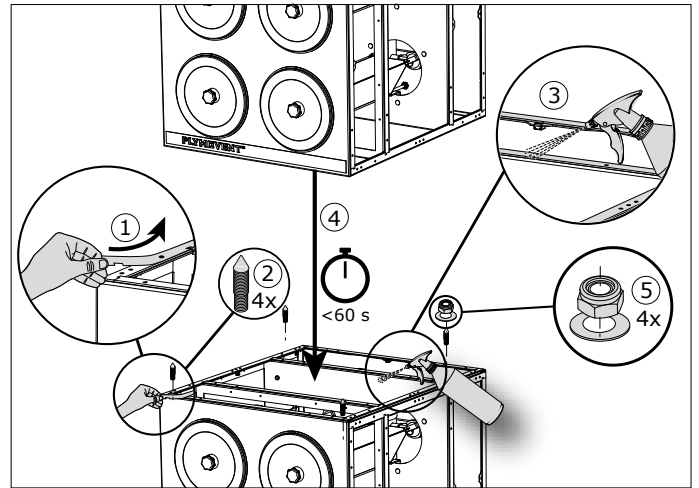

Fig. 4.18 Second filter module

Fig. 4.19

- Put a stud in the remaining 5 cage nuts between the filter modules and tighten them with a flange nut (B).

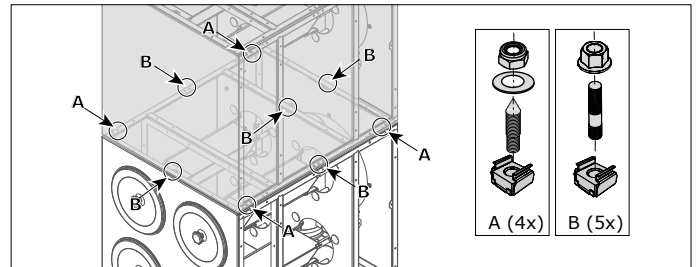

Fig. 4.19 Position of studs

#### 4.5.2 Air inlet module

The air inlet module contains 9 cage nuts for connection to the filter module.

Fig. 4.20

- Remove the 9 cage nuts<sup>17</sup> from the top of the upper filter module.

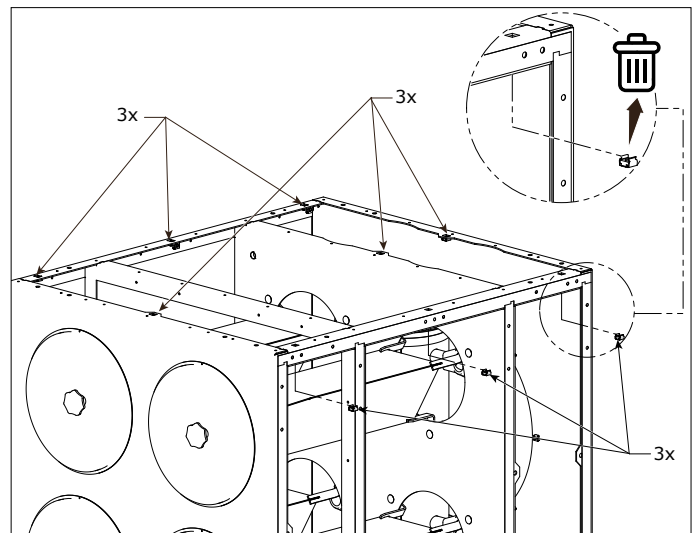

Fig. 4.20 Removal of the cage nuts

Fig. 4.21

- Remove the backing material of the seals on top of the filter module.
- Spray SealApplicator lubricant on the seals.

17. You may throw them away

- Put the air inlet module **within 60 seconds** on the filter module.



**ATTENTION**

Make sure that you install the rectangular openings over the filter compartment.

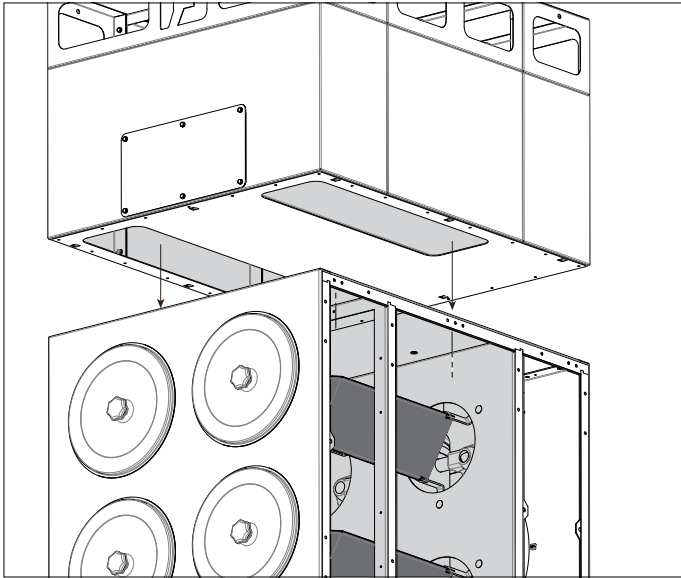

Fig. 4.21 Position of air inlet module

Fig. 4.22

- Put 9x bolt M20x8 with 9x washer M8 into the cage nuts to attach both components.

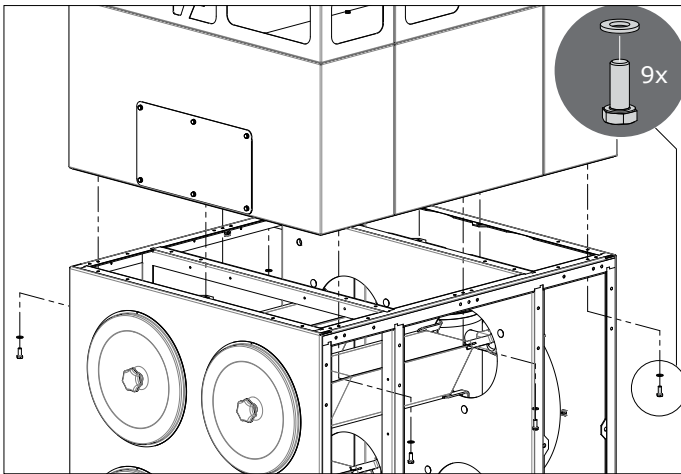

Fig. 4.22 Air inlet module on filter module

**4.5.3 End cap**

The air outlet module comes with an end cap.

- Put an end cap on the open side of the air outlet module.
- Fasten it with self-tapping screws.
- Use duct tape to make the connection airtight.

**4.6 Filter pressure hoses**

Each filter module contains a pneumatic hose with a T-connector.

Fig. 4.23

- Put each T-connector (D) in the back of each filter module.
- Connect the hoses in series.
- Put an end plug (A) in the last T-connector.
- Install the compressed air switch (B).

- Connect the loose end of the pneumatic hose to the compressed air switch (B) via the T-connector.
- Install a compressed air regulator (CAR-KIT or similar) (C) on the mounting frame. Set it to 5 bar.
- Install a pneumatic hose between the compressed air switch (B) and the compressed air regulator (C).



**ATTENTION**

Make sure that the airflow direction through the regulator is correct; this is indicated by the arrow on the back side.

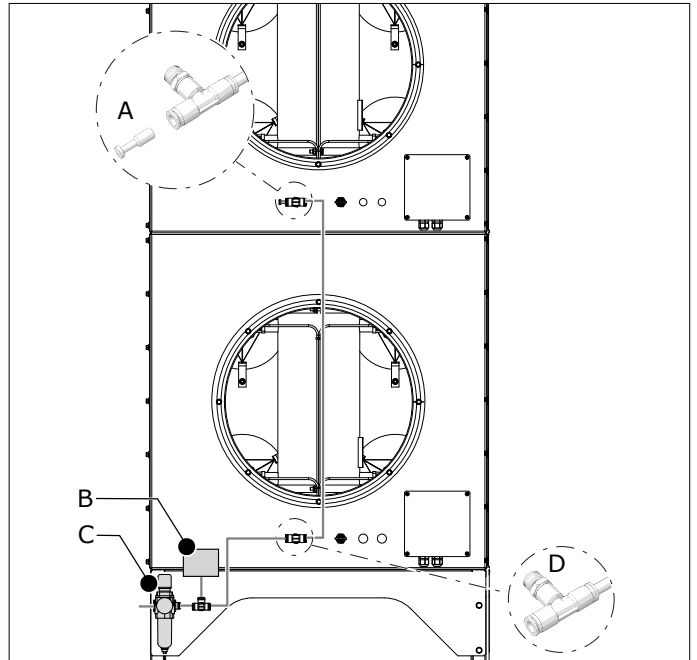

Fig. 4.23 Pressure hose



**WARNING**

Prevent damage to the cleaning mechanism. Make sure that the compressed air is free from oil and moisture (ref. ISO 8573-3 class 6).

**4.7 Cover plates**

Fig. 4.24

- Make additional holes in the seals. They must correspond with the holes in the filter module.
- (1) Remove the backing material of the seals.
- (2) Spray SealApplicator lubricant on the seals.
- (3) Put one cover plate within 60 seconds on the filter module.
- (4) Attach the cover plate with the flange screws.
- Repeat this procedure for the remaining cover plates.

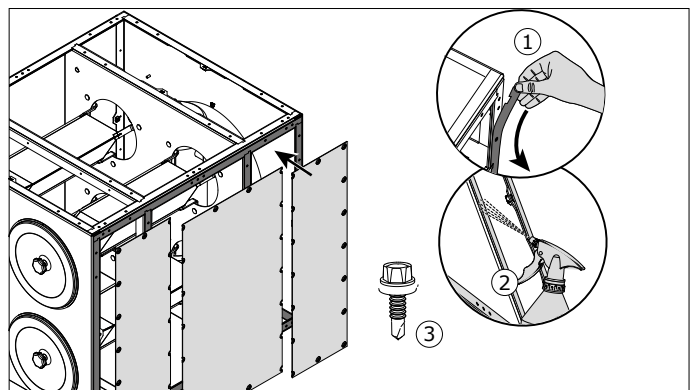

Fig. 4.24 Cover plates

## 4.8 Filter cartridges

To install the filter cartridges, do the following.

Fig. 4.25

- Loosen the star knob (F) and disassemble the cover plate (E), the nut (D) and the metal washer (C).
- Put the filter cartridge (B) on the cartridge holder (A).
- Install the removed parts in reverse order.

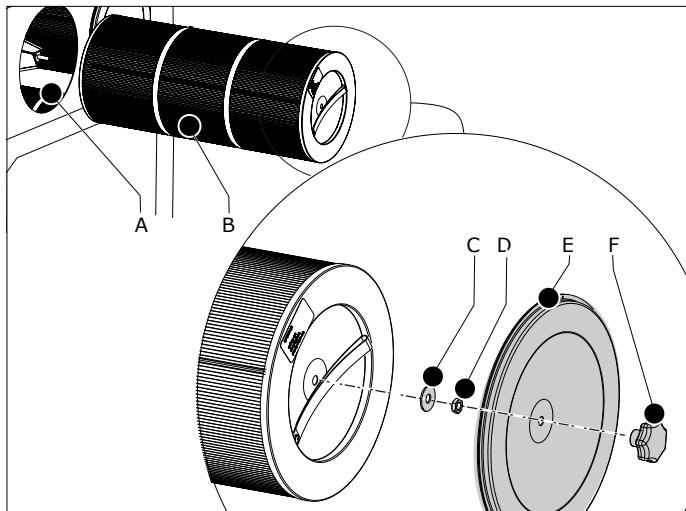

Fig. 4.25 Installation of the filter cartridges

**ATTENTION**

Make sure that the front of the filter cartridge aligns<sup>\*)</sup> with the filter housing, so that the lid closes well. If this is not the case, the filter cartridge is not positioned correctly. This can cause leakage and less efficient operation of the filter cartridge.

<sup>\*)</sup> tolerance: max. 2 mm (0.1 in.)

>2 mm

max. 2 mm

- Do the same procedure for the remaining filter cartridge(s).

## 4.9 Dustbin

Fig. 4.26

- Put the dustbin (D) below the hopper (A).
- Use the handle (C) to lift the dustbin and put it in the right position.
- Attach the dustbin to the hopper with the quick connect clamp (B).

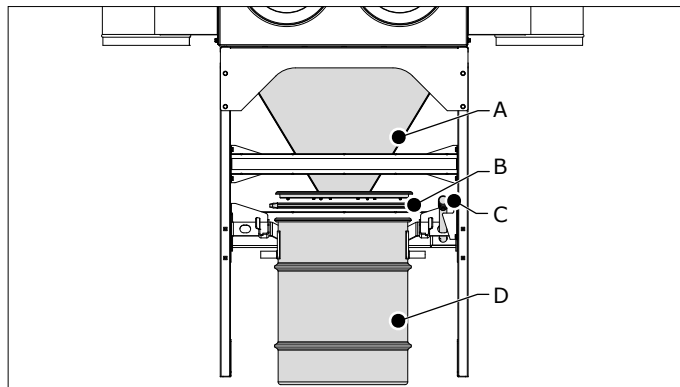

Fig. 4.26 Dustbin

### 4.9.1 Extraction fan

Fig. 4.27

- Put the extraction fan on the fan frame.

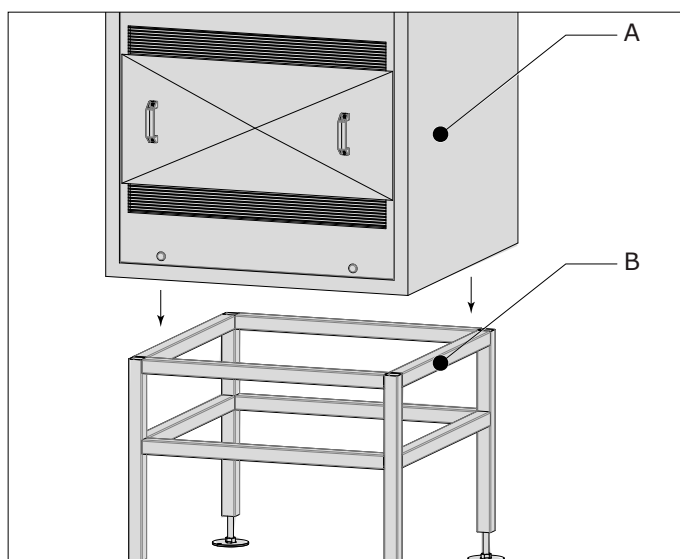

Fig. 4.27 Fan on frame

In the standard configuration, the inspection cover is located on the front side. It is possible to change the inspection cover to the rear.

- If desired/necessary, change the position of the inspection cover.

### 4.9.2 Connection of the filter system to the fan

The outlet of the filter system is fitted with a connection ring. Other necessary parts:

- adapter Ø 400 mm (15.7 in.)
- duct connector Ø 400 mm (15.7 in.) with KEN-LOK sealing

Fig. 4.28

- Put the adapter (B) on the connection ring (A). Do not slide the adapter all the way over the ring, but leave approx. 20 mm (1 in.).

Disassemble the connection ring from the filter system to facilitate assembly. Use a cordless drill with a long pin to reinstall.

- Attach the adapter to the connection ring with 4 self-tapping screws.
- Make this assembly airtight with duct tape (preferably two laps).
- Install the duct connector (C) to the adapter (B). Attach it with 4 self-tapping screws.

- Install the fan (D).
- Make sure that the filter outlet aligns with the fan inlet. If necessary, change the height of the adjusting feet of the fan frame.
- Slide the duct connector all the way inside the inlet opening of the fan.

 Depending on the specific circumstances, it might be necessary to partly or fully close one or more nozzles.

**ATTENTION**  
 Make sure that both the filter system and the extraction fan are level. Check both horizontally and vertically.

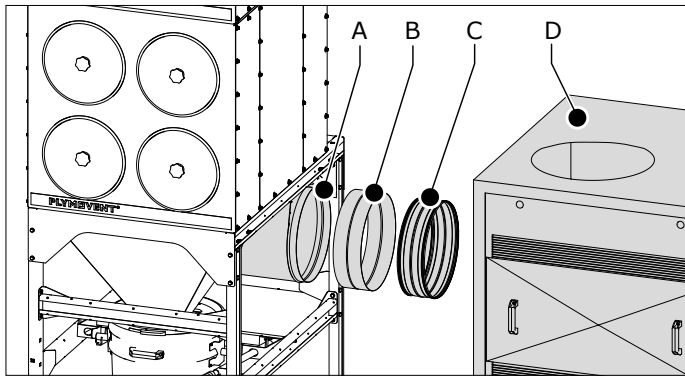

Fig. 4.28 Connection of the filter system to the fan

**4.9.3 Silencer**

Fig. 4.29

- Put a duct connector (C) in the outlet opening (D) of the fan. Attach it with 8 self-tapping screws.
- Put the other duct connector (A) on top of the silencer (B). Attach it with 8 self-tapping screws.
- Put the silencer on the lower duct connector (C). Attach it with 8 self-tapping screws.

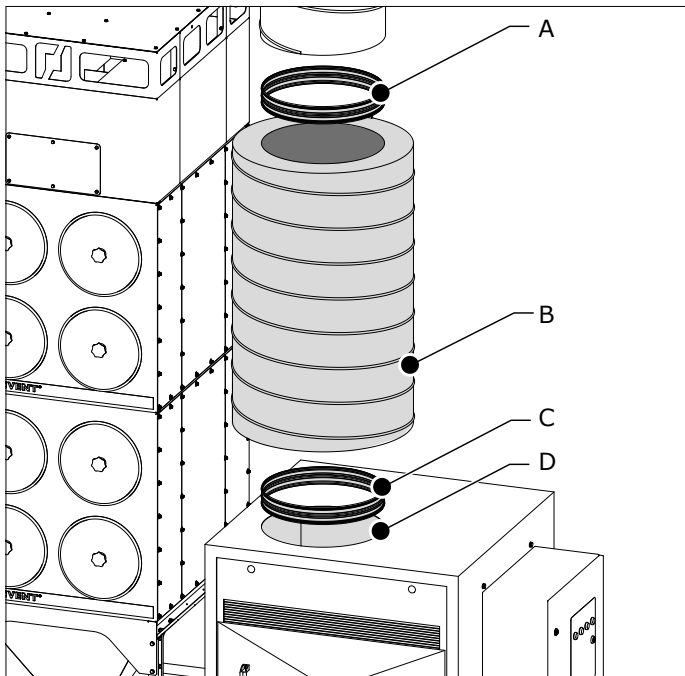

Fig. 4.29 Mounting of the silencer

**4.9.4 Outlet unit with adjustable nozzles**

- Determine the direction of the outlet unit and the airflow direction of the individual nozzles.

Fig. 4.30

- Put the outlet unit (A) on the duct (B). Attach it with 4 self-tapping screws.
- Put the duct on the silencer. Attach it with 8 self-tapping screws.

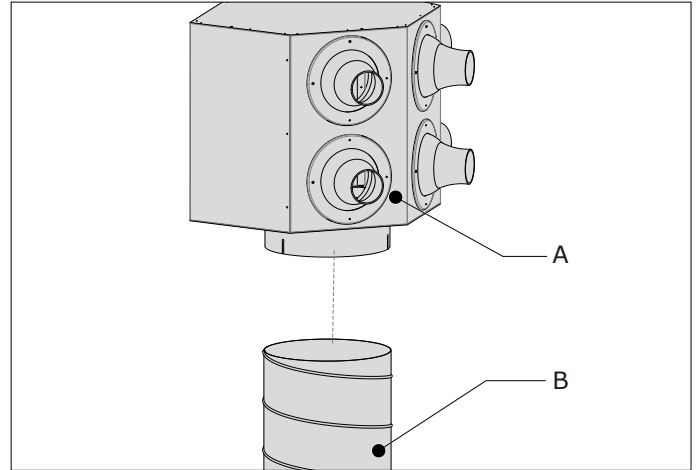

Fig. 4.30 Outlet unit on duct

You must attach the vertical duct to the filter system<sup>18</sup> to strengthen the configuration. The air inlet module contains holes in the top edge to insert a threaded rod.

To attach the duct to the filter system, do the following.

Fig. 4.31

- Install two threaded rods with nuts to the air inlet module (position A+B). Tighten the nuts (C).
- Install the other side of the threaded rods to the duct with the support bracket and nuts (D).
- Make sure that the duct and the filter system are fully parallel to each other (E).

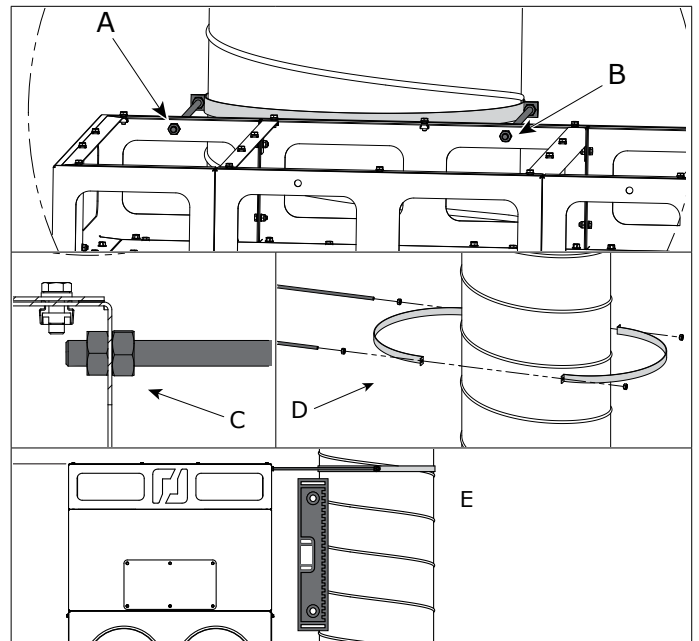

Fig. 4.31 Fastening of the duct

<sup>18</sup>. Instead of fastening the duct to the filter system, you can attach it to the wall

## 4.10 Pneumatic connection

Fig. 4.32

- Connect a compressed-air line to the optional CAR-KIT or similar (A). Attach the line securely.



### WARNING

Prevent damage to the cleaning mechanism. Make sure that the compressed air is free from oil and moisture (ref. ISO 8573-3 class 6).

### 4.10.1 Filter pressure sensor

To monitor the filter pressure, you must install pneumatic hoses between the filter system and the internal filter pressure sensor. This sensor measures the pressure difference between the filter compartment and the housing of the compressed air tank.

Fig. 4.32

- Remove the cover caps from the + and - (B+C) on the lower filter module.
- Install a cable gland in the + and - connection.

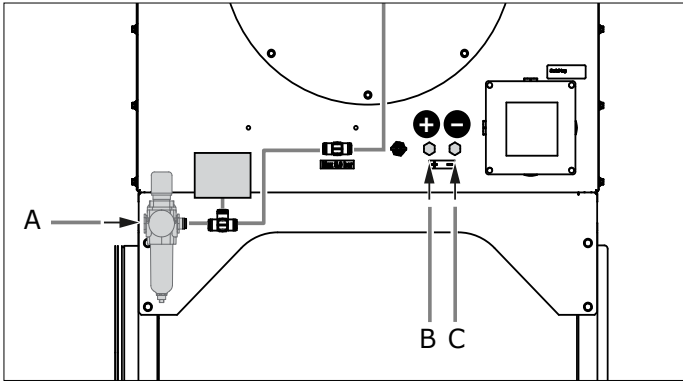

Fig. 4.32 + and - connection

Fig. 4.34

- Remove the filter cap and install another cable gland inside the filter module (+).
- (1) Put a pneumatic hose through the + connection.
- (2) Put the hose through the other cable gland into the filter compartment.
- (3) Put the other hose through the - connection.

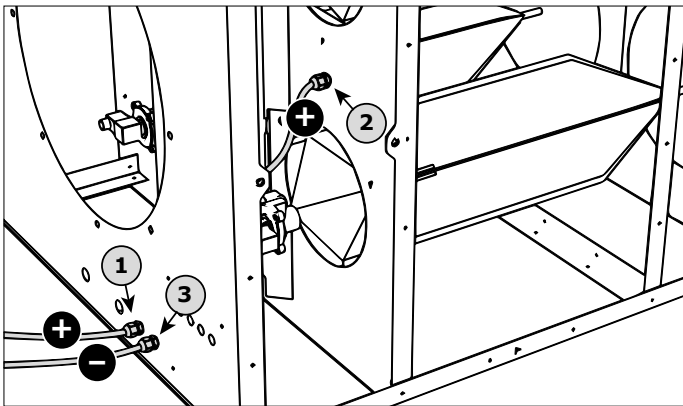

Fig. 4.33 Cable glands and pneumatic hoses

Fig. 4.34

- Make sure to have approx. 25 mm (1 in.) (A+B) hose end.
- Tighten all cable glands.

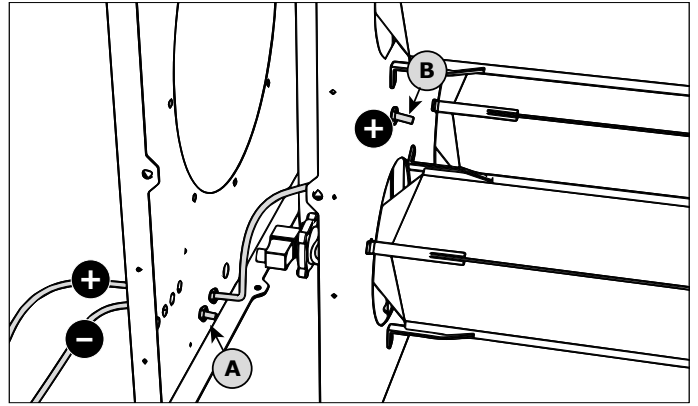

Fig. 4.34 Pneumatic hose ends

Fig. 4.36

- Connect the other side of the pneumatic hoses to the corresponding push-in fittings (A) in the bottom plate of the Panel.

### 4.10.2 Fan pressure sensor

To monitor the fan pressure, you must connect a pneumatic hose to the internal fan pressure sensor.

Fig. 4.35

- Determine the position of the pressure sensor in the vertical duct. Best position: approx. 500 mm (20 in.) below the outlet unit.
- Drill two holes  $\varnothing$  10 mm (0.4 in.) in the vertical duct at the indicated positions (A+B).
- Connect the pneumatic hose (D) with T-connector (C) to the duct with the supplied connection material.

Fig. 4.36

- Connect the other side of the pneumatic hose to the corresponding push-in fitting (B)<sup>19</sup> in the bottom plate of the Panel.

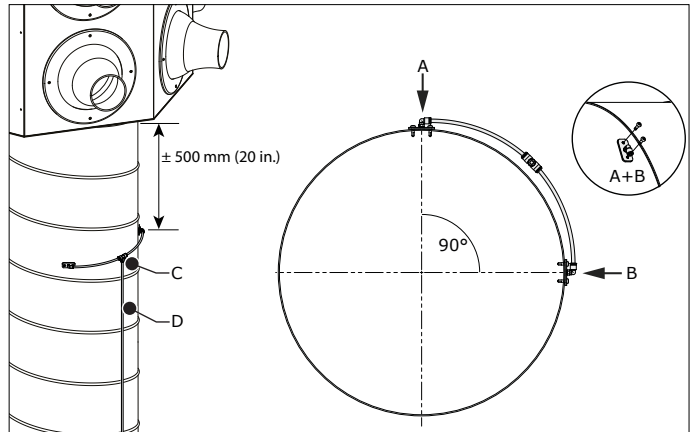

Fig. 4.35 Mounting of the pressure sensor

### 4.10.3 Connection of pneumatic hoses to the Panel

Refer to paragraph 4.10.1 and 4.10.2.

19. Push-in fitting - (minus) remains unused

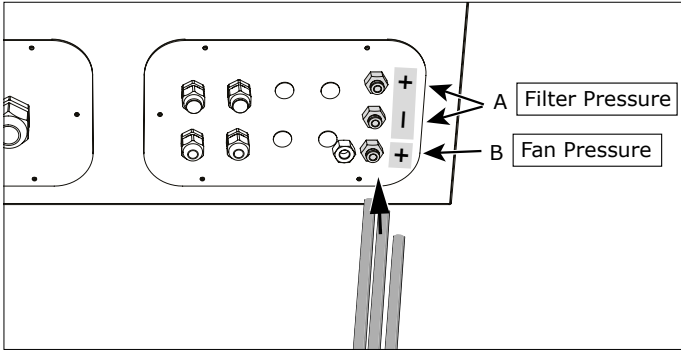

Fig. 4.36 Connection of pneumatic hoses to the Panel

#### 4.11 Mounting of the control equipment

You must install the Panel and HMI at a clearly visible and accessible position.



	<b>ATTENTION</b> Do not expose any component of ControlPro to vibrations or heat radiation.
	We recommend to install the Panel on the side of the fan housing.

##### 4.11.1 Panel

Fig. 4.37

- Attach the mounting brackets (A) to the Panel with the supplied mounting material (B).

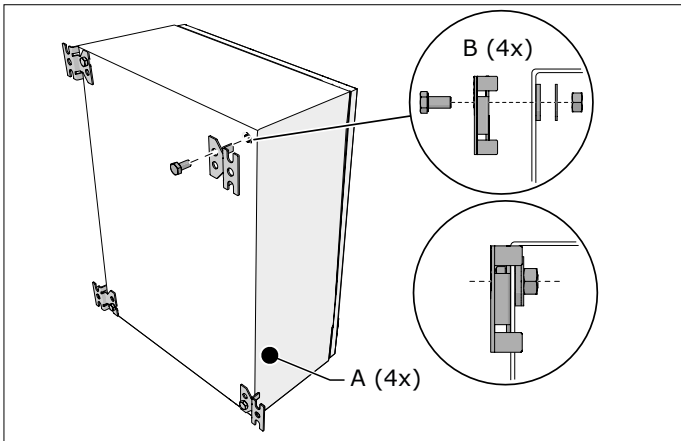

Fig. 4.37 Mounting brackets

Fig. 4.38

- Install the Panel to the fan housing or to the wall. Make sure that it is level.

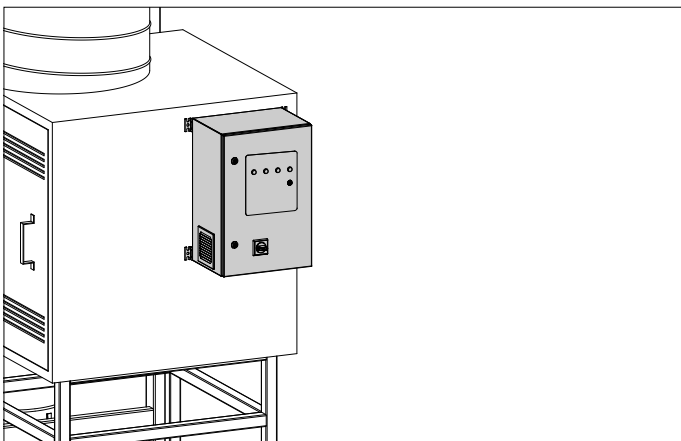

Fig. 4.38 Mounting of the Panel to the fan housing

The housing contains two removable bottom plates, that contain the following cable glands and connectors:

Fig. 4.38

##### High voltage compartment (left bottom plate)

- A Cable gland M25 for the motor cable
- B Cable gland M16 for the PTC cable
- C Cable gland M25 for the mains cord

##### Low voltage compartment (right bottom plate)

- D Universal cable glands M16 (4)
- E Push-in fittings (3) for the pressure tubes<sup>20</sup>

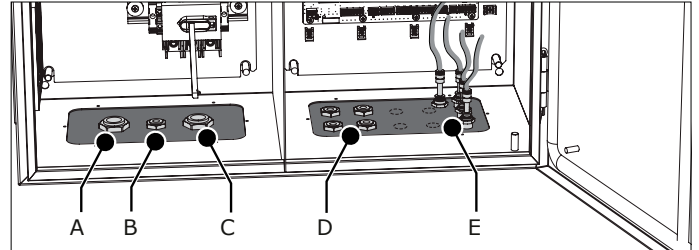

Fig. 4.38 Bottom plates

Table I on page 32 gives an overview of the necessary and optional cables that you need to install the system.

- Depending on the selected options, determine the number and type of cables that you need.

If the number exceeds 4 cables (excluding the mains cord), you must install additional cable glands in the right bottom plate. In that case, do the following.

Fig. 4.39

- (1) Loosen the pneumatic hoses from the push-in fittings on the inside of the Panel.
- (2) Loosen and (3) remove the right bottom plate.
- Open the necessary number of knock-out holes<sup>21</sup>.
- (4) Put additional cable glands M16 (E) in the bottom plate and tighten them.
- Install the bottom plate.
- Fasten the pneumatic hoses to the push-in fittings.

	<b>WARNING</b> You must remove the bottom plate to put additional cable glands to avoid damage to the interior parts of the Panel.
--	---

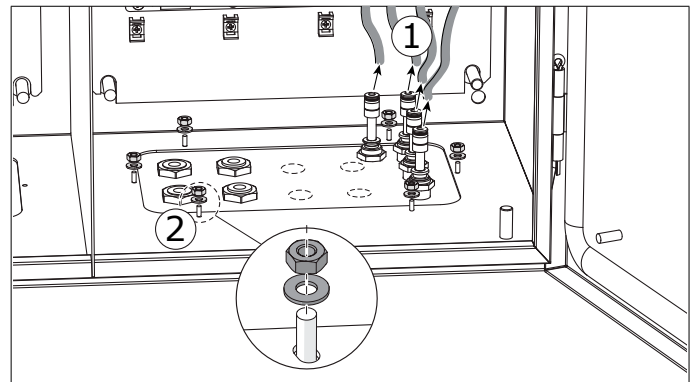

20. Fan pressure + | Filter pressure + and -

21. Max. 4



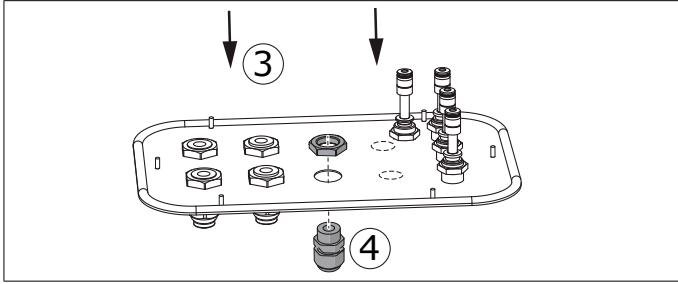

Fig. 4.39 Additional cable glands (optional)

#### 4.11.2 HMI

Fig. 4.40

- Loosen the locking screw (C) and the HMI (B) from the bracket (A).
- Install the bracket to the wall. Use all 3 mounting points and make sure that it is level.
- Put the HMI on the bracket.

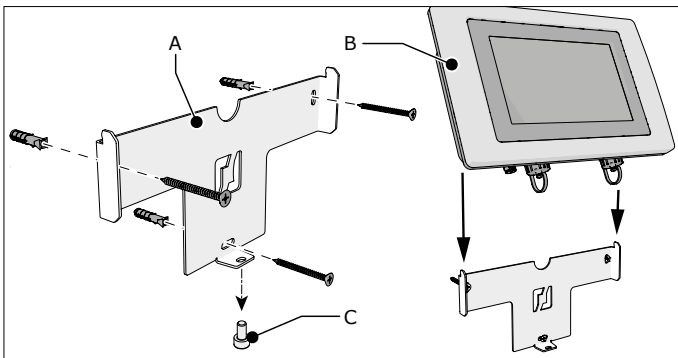

Fig. 4.40 Mounting of the HMI

Fig. 4.41

- Attach the HMI with the locking screw (A).
- Connect the HMI cable (C) to the CAN connector (B) and tighten it.

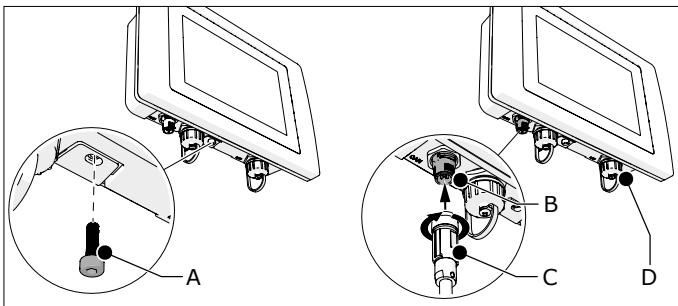

Fig. 4.41 Locking screw and HMI cable

Optional:

Fig. 4.42

- Connect the supplied ethernet field connector (B) to the ethernet cable (A).
- Remove the dust cap (refer to Fig. 4.41D) and put the ethernet cable in the corresponding LAN port.

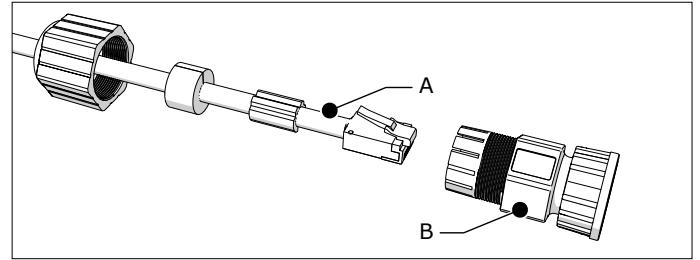

Fig. 4.42 Ethernet field connector

#### 4.12 Electric connection



This chapter describes the electric connection of all necessary and optional components to the Panel.

Depending on the specific configuration of the filter system, some of the connections on the PC board inside the Panel remain unused. The PC board contains detachable screw terminal blocks ("connectors").

Table I on page 32 gives an overview of the necessary and optional cables<sup>22</sup> that you need to install the system.



#### WARNING

- Shorten excessive cable lengths. A coil or bundle of cables can cause electromagnetic interference.
- Make sure that you connect the wiring in the correct way. Wrong wiring may cause permanent damage to the PC board.
- Use cable glands to insert cables into the Panel.
- Keep the blanking plugs on the cable glands that are not in use to avoid pollution of the Panel.



- For all connections, also refer to the separately supplied electrical diagram.
- Refer to Table II on page 32 for a specification of the digital inputs (high/low).



#### General instructions to connect a cable to a certain connector (unless otherwise stated)

Wire stripping:

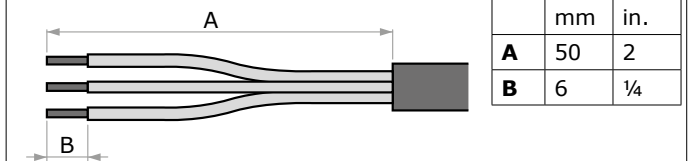

- (1) Put the cable through a cable gland M16 into the Panel.
- (2) Carefully remove the connector from the PC board. Pull the connector in a *horizontal* direction.
- Cut the cable to the correct length and strip the wires.

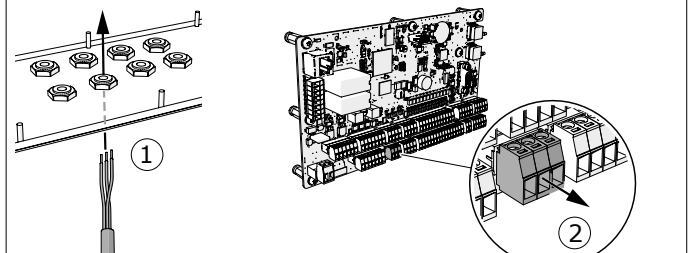

22. Recommended cable specifications; use cables with a max. wire diameter 1,5 mm<sup>2</sup> (AWG 16)

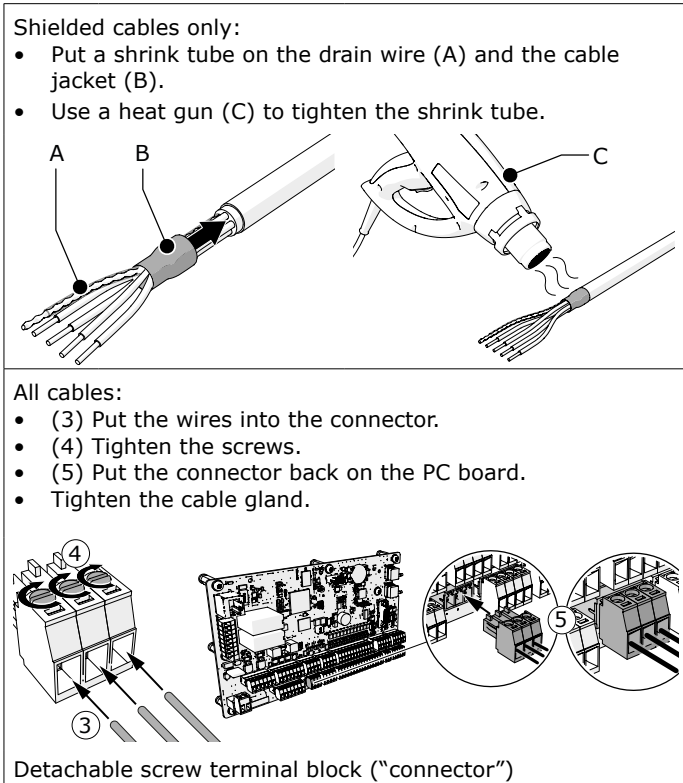

For an overview of all electric and pneumatic connections, refer to Fig. IV on page 28.

#### 4.12.1 Mains cord (cable #5)

To install the mains cord to the Panel, do the following.

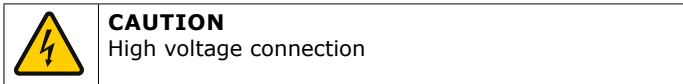

Fig. 4.43

- Put the mains cord (B) through the right cable gland.
- Connect it to connectors L1, L2 and L3 on the terminals of the main switch (A) and to PE<sup>23</sup> on the left connector.
- Fasten the cable gland.

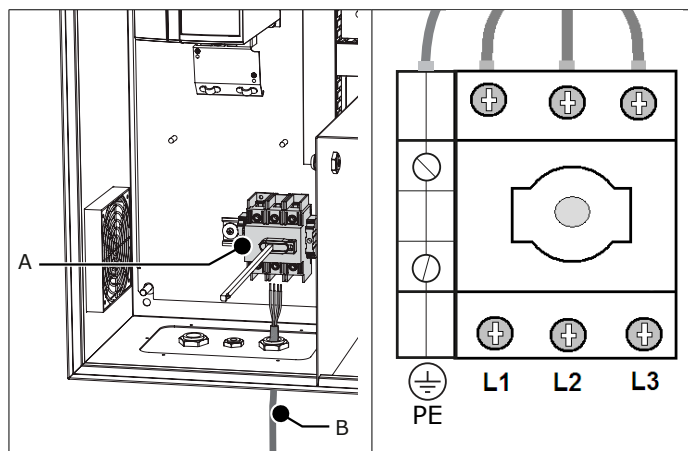

Fig. 4.43 Mains cord

#### 4.12.2 Motor cable + PTC cable

To install the motor cable and PTC cable to the Panel, do the following.

Fig. 4.44

- Put the motor cable (A) through the left cable gland.
- Put the PTC cable (B) through the middle cable gland.

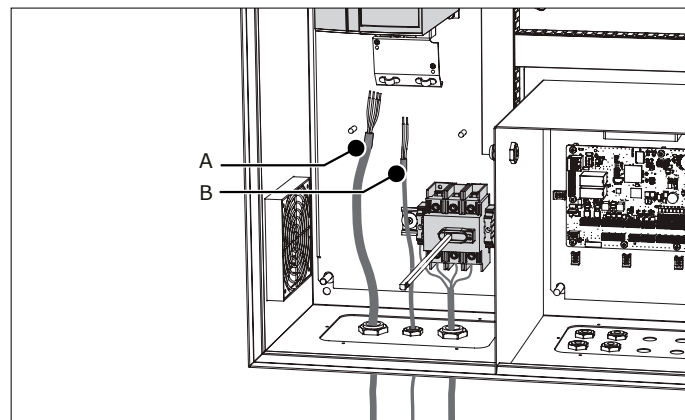

Fig. 4.44 Motor cable and PTC cable

To connect the motor cable and the PTC cable to the VFD (frequency inverter), do the following.

Fig. 4.44 + Fig. 4.47 (electrical diagram)

#### Connection of the motor cable to the VFD

- Remove the front cover (lower part) of the VFD inside the Panel.
- Remove the outer insulation from the motor cable at the position of the EMC clamp (A).
- Connect the motor cable in accordance with the electrical diagram.
- Fasten the EMC clamp.

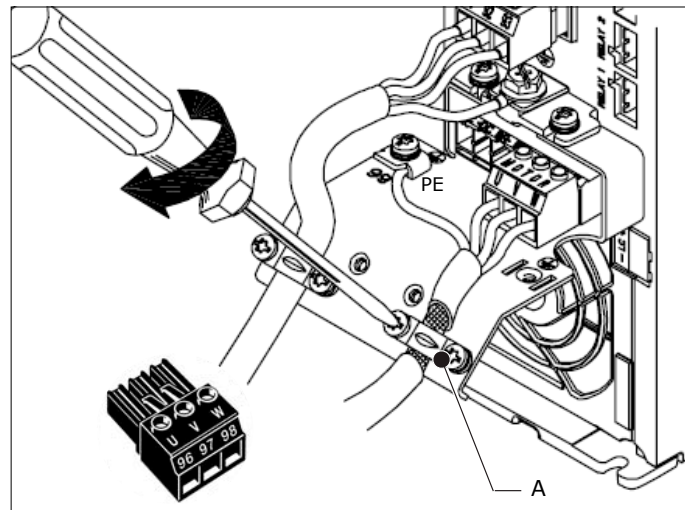

Fig. 4.45 Motor cable to VFD

Fig. 4.46 + Fig. 4.47 (electrical diagram)

#### Connection of the PTC cable to the VFD

- Connect the PTC cable in accordance with the electrical diagram.
  - A: screwdriver
  - B: wires 13+33

23. PE = Protective Earth

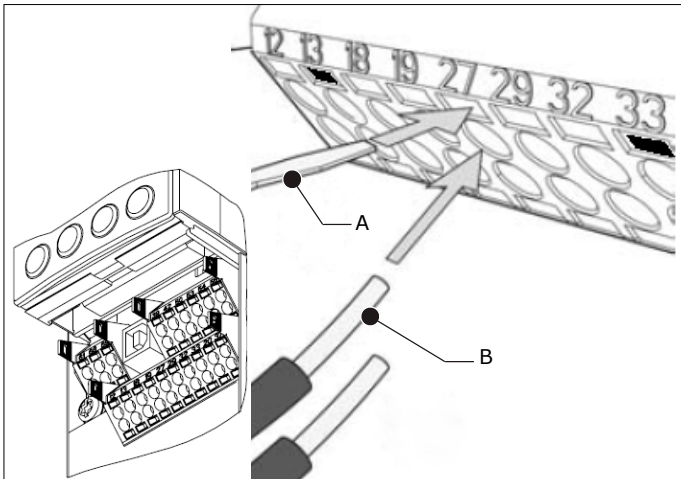

Fig. 4.46 PTC cable to VFD

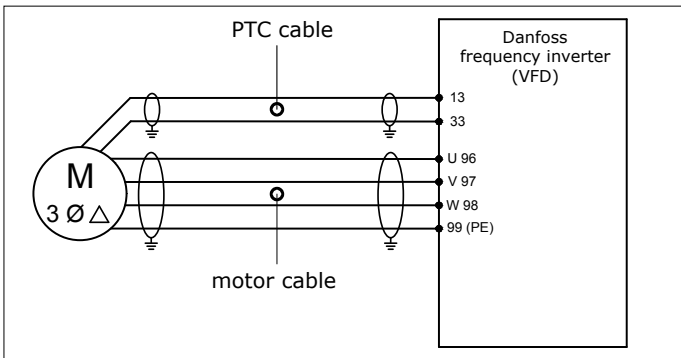

Fig. 4.47 Electrical diagram

- Fasten the cable glands of the motor cable and the PTC cable.

#### Connection of the motor cable and the PTC cable to the fan motor

Fig. 4.48

- Connect the wires of the motor cable to the connectors U1, V1, W1 (C) and PE (A) in the junction box of the fan.
- Connect the metal plates (supplied in a plastic bag within the junction box) to obtain a "delta" connection. Make sure that the connection is in accordance with the motor plate.
- Connect the wires of the PTC cable (incl. shield to PE) to the PTC connection (B) in the junction box. This connection is *not* phase sensitive.

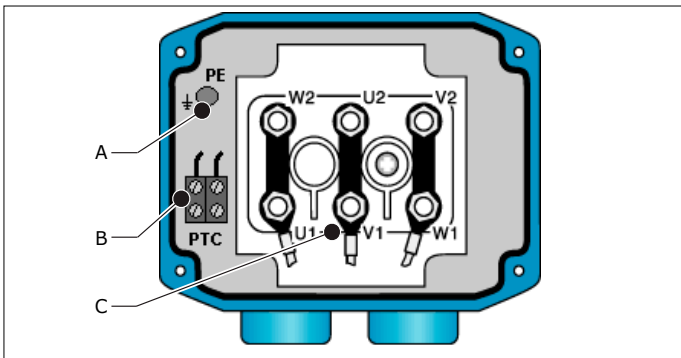

Fig. 4.48 "Delta" connection of the motor cable to the fan motor

#### 4.12.3 Panel → HMI

CAN HMI				
1	2	3	4	5
+ 24V	CAN_H	CAN_L	GND	SHD

Wiring colours  
+24V red  
CAN\_H white  
CAN\_L blue  
GND black  
SHD drain wire (with shrink tube)

**Cable #1**

[page 16]

Fig. 4.49 Connection Panel → HMI

#### 4.12.4 Control cable

Cable #20 connects the compressed air switch with the Panel.

Digital input 6-12															
1	2	3	4	5	6	7	8	9	10	11	12	13	14	15	16
+ 24V	IN 6	+ 24V	IN 7	+ 24V	IN 8	+ 24V	IN 9	+ 24V	IN 10	+ 24V	IN 11	+ 24V	IN 12	COM2	GND

**Cable #20**

[page 16]  
input IN 10

Fig. 4.50 Connection of the control cable

#### 4.12.5 Input signals (options)

- If desired, you can connect the ControlPro to a start/stop signal and/or an alarm signal from an external device;
- start/stop signal: cable #6
  - alarm signal: cable #7

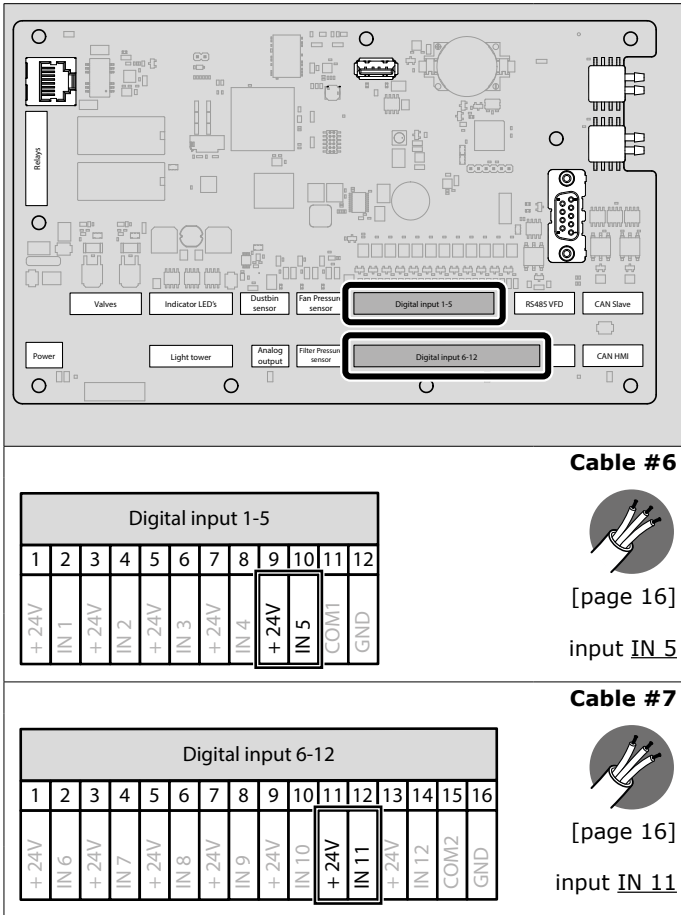

Fig. 4.51 Connection of external input signals

**4.12.6 Output relays (cable #8 and #9) (options)**

Both output relays are available for connection to an external device. Possible events to activate the relays are:

- Start/stop fan<sup>24</sup>
- Filter cleaning active
- System mode: Automatic
- Warning active
- Warning signals: no compressed air / dustbin full
- Alarm active
- Alarm signals: no compressed air

**ATTENTION**

- You can choose to connect the cables as NO (normally open) or NC (normally closed).
- Max. connection: 30 VDC / 2,5 A per relay.

- If desired, connect Relay 1 and/or Relay 2 to an external device.

You must select the specific event that you want to activate the relay(s) on the HMI (refer to screen no. 1.4).

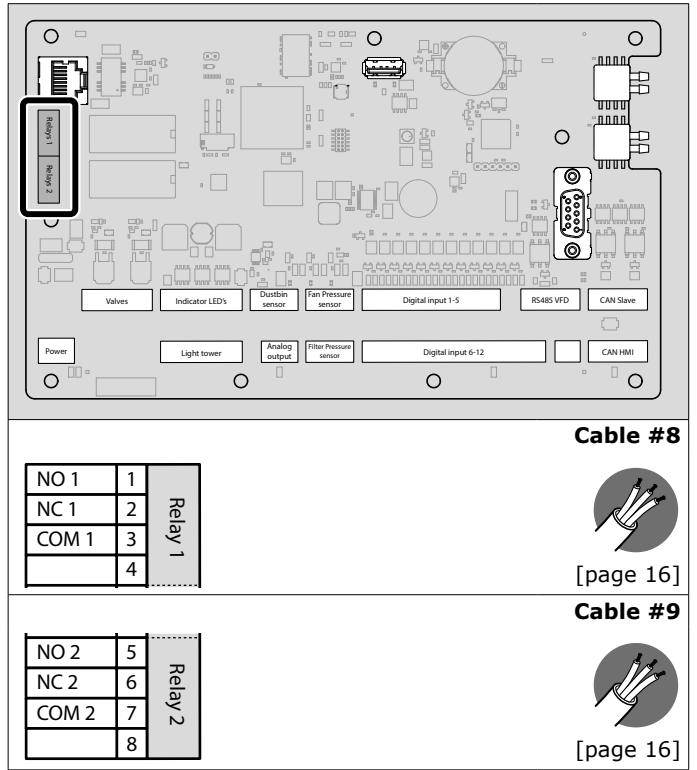

Fig. 4.52 Connection of relay outputs

**4.12.7 LightTower (option)**

The LightTower contains the same pilot lights as the Panel, including the buzzer.

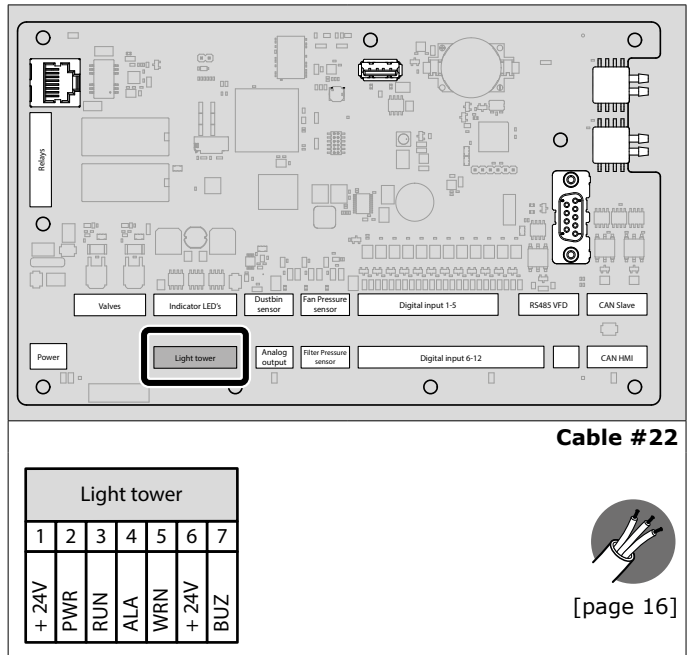

Fig. 4.53 Connection of LightTower

**5 COMMISSIONING**

**5.1 Installation wizard**

- Make sure that the Panel is connected to the mains.
- Turn the main switch (refer to Fig. 6.1F) to "on". The system will start up<sup>25</sup>.





24. E.g. a BoosterFan

25. Indication: the white LED on the Panel is blinking

The HMI starts the installation wizard.

- Complete the installation wizard.

	Refer to paragraph 5.3 and 5.3.1 for more information about the VFD (frequency inverter) and the PID setpoint.
	Select the question mark on the touch screen for extensive explanation on all settings. 

## 5.2 Extraction fan

- Turn the main switch (refer to Fig. 6.1F) to "off" and open the Panel.
- Turn the bar that is connected to the main switch to energize the Panel manually.
- Push the START/STOP FAN button (refer to Fig. 6.1F) to start the fan.
- Make sure that the direction of rotation of the motor is correct.

If the direction of rotation of the motor is not correct:

- Invert any two connections (96/97/98) on the VFD to change the motor direction.
- Push the button again to stop the fan.

## 5.3 VFD (frequency inverter)

The VFD is integrated in the Panel. The fan speed is controlled by the system pressure. To operate the system, you must know or determine the airflow in the duct that is necessary to get the correct throw and air circulation.

The required system pressure must be programmed in the HMI to keep the airflow at a constant level, independently from the (increasing) pressure drop caused by the filter cartridges. This system pressure is called the 'PID setpoint', which arranges the necessary fan speed (Hz) accordingly.

The table below indicates the throw related to the airflow and fan speed<sup>26</sup>.

Throw	Airflow/ nozzle	Total airflow	Frequency
20 m (65 ft)	1000 m <sup>3</sup> /h (590 CFM)	6000 m <sup>3</sup> /h (3530 CFM)	30 Hz
40 m (130 ft)	1500 m <sup>3</sup> /h (885 CFM)	9000 m <sup>3</sup> /h (5300 CFM)	50 Hz

For more detailed information, refer to Fig. X on page 31. Fig. XI shows the horizontal throw per nozzle.

### 5.3.1 PID setpoint of the fan pressure

To determine and set the PID setpoint, do the following.

- Go to the Settings menu on the HMI.
- Enter PIN.

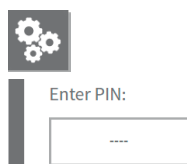

Fig. 5.1

- Select menu **PID setpoint of the fan pressure** (or enter **2.2.1** on the numeric keypad).

26. All nozzles 100% open

- Select the button **Start fan**.
- Measure the actual airflow with a flowmeter. Best measuring position: approx. 500 mm (20 in.) below the outlet unit of the MDB-Diluter.
- Use the buttons **+** or **-** to determine the setpoint to reach the desired airflow. At this setpoint, the frequency must not exceed 45Hz.
- Select **Stop fan** when the desired airflow is reached.
- Select **Finish** to exit the screen. The new values will be saved.

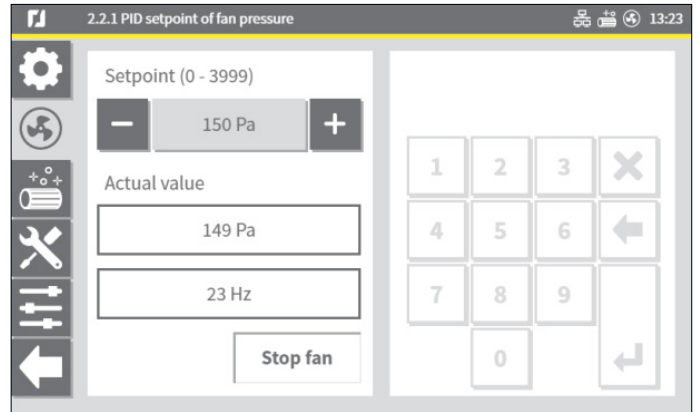

Fig. 5.1 PID setpoint

## 6 USE



### WARNING

During use, always use Personal Protective Equipment (PPE) to avoid injury. This also applies for persons who enter the work area.

## 6.1 Control equipment

### 6.1.1 Panel

The control panel contains the following controls and indicators:

#### Outside

Fig. 6.1 (also refer to Fig. V on page 28)

- A White LED | POWER ON
  - LED off: system is off
  - LED blinking: system is starting up
  - LED on: system is ready
- B Green LED | FAN RUNNING
  - LED off: fan is off
  - LED blinking: fan is ramping down<sup>27</sup>
  - LED on: fan is running
- C Yellow LED | WARNING
  - LED off: no problem
  - LED on<sup>28</sup>: refer to the HMI for the cause of the warning
- D Red LED | ALARM
  - LED off: no problem
  - LED on<sup>29</sup>: refer to the HMI for the cause of the alarm
- E Buzzer | acoustic signal
  - together with the ALARM signal (D)
  - in some cases: together with the WARNING signal (C)
- F Main switch

27. Ramp down time: 60 seconds

28. The system continues to run

29. The system stops running

## Inside



### ATTENTION

The buttons inside the Panel are for service purposes only. You can control the entire system via the HMI, therefore, the buttons inside the Panel are not necessary for daily use.

G Button | START/STOP FAN

H Button | FILTER CLEANING

- to activate an additional filter cleaning cycle
- to suppress the buzzer (push and hold for 5 seconds)

I Switch 0-1 | SERVICE MODE

- 0: normal mode
- I: to lock the touch screen of the HMI for service purposes

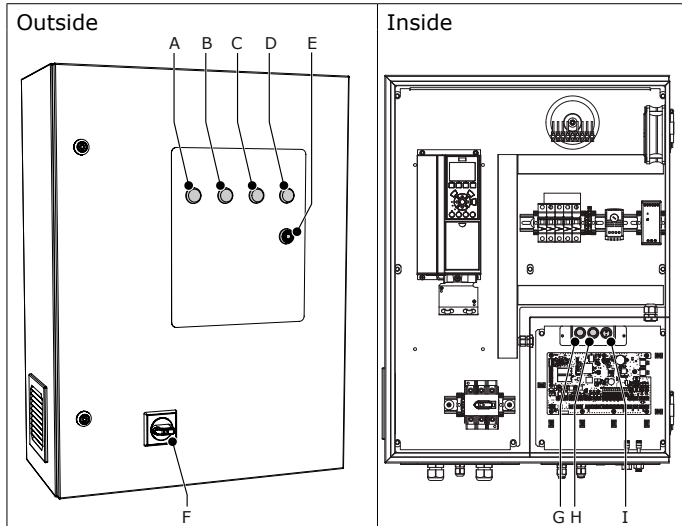

Fig. 6.1 Control panel

### 6.1.2 HMI

Refer to the online user manual ControlPro for extensive explanation about the HMI:  
[www.plymovent.com/manuals/controlpro](http://www.plymovent.com/manuals/controlpro)

---

**PLYMOVENT®**  
clean air at work

**EN** User manual  
**NL** Gebruikershandleiding  
**DE** Betriebsanleitung  
**FR** Manuel opérateur  
**ES** Instrucciones para el uso

[www.plymovent.com/manuals/controlpro](http://www.plymovent.com/manuals/controlpro)

0000112330

The online user manual is available in English language only. Short user manuals (PDF format) in other languages are in process. Contact your supplier about the availability of the short user manual in your own language.

## 6.2 Use

Depending on the specific configuration and system settings on the HMI, you can activate the fan and cleaning system manually or have the entire system run fully automatically.

### 6.2.1 HMI

The HMI shows the actual system status at all times. To control the entire system via the HMI is self-explanatory.

### 6.2.2 Panel

Manually activated functions for service purposes only:

Fig. 6.1

- Button START/STOP FAN (G)
- Button FILTER CLEANING (H)<sup>30 31</sup>

## 7 MAINTENANCE

### 7.1 Periodic maintenance



The system has been designed to function without problems for a long time with a minimum of maintenance. In order to guarantee this some simple, regular maintenance and cleaning activities are required which are described in this chapter. If you obey the necessary caution and carry out the maintenance at regular intervals, any problems occurring will be detected and corrected before they lead to a total breakdown.

The indicated maintenance intervals can vary depending on the specific working and ambient conditions. Therefore, we recommend to thoroughly inspect the complete system once every year beside the indicated periodic maintenance. For this purpose contact your supplier.

The maintenance activities in the tables below indicated by [\*] can be carried out by the user; other activities are strictly reserved for well trained and authorized service personnel.

#### 7.1.1 MDB-Diluter

	<b>WARNING!</b> Overdue maintenance can cause fire.
	<b>WARNING</b> Always fully <b>disconnect</b> the system from the mains before you carry out maintenance jobs as mentioned below. First read the maintenance regulations at the beginning of this manual.
	<b>WARNING</b> Always disconnect the compressed air supply before you carry out maintenance jobs.

Component	Action	Frequency: every X months	
		X=3	X=6
Dustbin	Check level of dust and dirt particles. Empty if necessary (ref. par. 7.2)	X <sup>1</sup>	X <sup>1</sup>
Air inlet module	Clean the inside; refer to par. 7.4	X	
Housing	Make sure that there is no air leakage		X

30. You cannot stop/interrupt the filter cleaning cycle

31. You cannot activate this button during the first 40 running hours of the system and within 40 running hours after filter replacement, to maintain the protective layer of precoat material on the filter cartridges

Component	Action	Frequency: every X months	
		X=3	X=6
Compressed air system	Make sure that the connection is correct		X
	Make sure that the pressure is correct (4-5 bar / 60-75 PSI)		X
	Make sure that the valves and membranes are not damaged		X
Filter cartridges	Make sure that the position is correct; refer to par. 4.8		X
Bolts	Make sure all bolts are correctly tightened		X

### 7.1.2 Control equipment

#### Panel

	<b>WARNING</b> If applicable, put the Panel in the Service Mode before you do the activities as stated below; refer to Fig. 6.1H.
--	--

Action	Frequency: every X months	
	X=1	X=3
Clean the outside with a non-aggressive detergent		X [*]
Make sure that the cable glands are correctly tightened		X
Check the aluminium inlet grid for pollution. Take it out and clean it with compressed air	X [*]	
Clean the inside with an industrial vacuum cleaner		X [*]
Make sure that all detachable screw terminal blocks on the PC board are connected		X

#### HMI

Action	Frequency: every X months	
	X=3	X=12
Clean with a non-aggressive detergent	X	
Make sure that the HMI cable is connected	X	
Check for firmware updates; refer to the online user manual		X

### 7.2 Emptying the dustbin

You must empty the dustbin regularly.



		<b>Personal protective equipment (PPE)</b> Always wear face mask and gloves during emptying the dustbin. Use the supplied dustbin lid during transport.
	<b>WARNING</b> Do <b>not</b> remove the dustbin while the fan is running.	

Fig. 7.1

- Turn off the main switch on the Panel to de-energize the entire system.
- Disconnect the compressed air supply.
- Loosen the drain valve (A) to empty the compressed air tank.
- Tighten the drain valve.

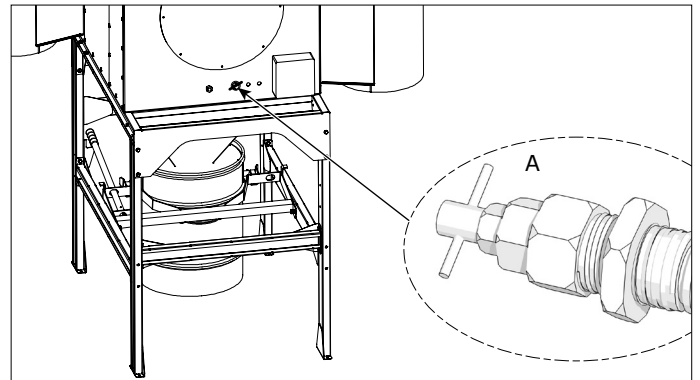
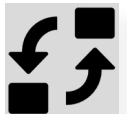





Fig. 7.1 Drain valve

- Loosen the quick release clamp.
- Release the lifting pin and lower the dustbin.
- Pull the dustbin forward.
- Seal the disposal sack securely and take it out.
- Place a new disposal sack in the dustbin.
- Install the dustbin in reverse order.
- Dispose of the full sack in accordance with state or local regulations.
- Connect the compressed air.

### 7.3 Filter replacement

Replace all filter cartridges at the same time.



		<b>Personal protective equipment (PPE)</b> Always wear face mask and gloves during filter replacement.
	<b>WARNING</b> Do <b>not</b> replace the filter cartridges while the fan is running.	

The lifespan of the filter cartridges strongly depends on the welding process, the composition of the welding fumes, the intensity of use and the humidity.

The Panel and/or HMI indicates when filter replacement is necessary.

To replace the filter cartridges, do the following.

- Turn off the main switch on the Panel to de-energize the entire system.
- Disconnect the compressed air.
- Loosen the drain valve (refer to Fig. 7.1A) to empty the compressed air tank.
- Tighten the drain valve.

Fig. 7.2

- Loosen the star knob (F) and disassemble the cover plate (E), the nut (D) and the metal washer (C).
- Remove (one of) the upper filter cartridge(s)<sup>32</sup> (B) and put it in the plastic sack in which the replacement filter cartridge is supplied.
- Seal the sack securely.

32. Removing the upper filter cartridges first, keeps the release of dust to a minimum

- Put a new filter cartridge on the cartridge holder (A) and attach it with the disassembled parts.
- Do the same procedure for the lower filter cartridges.
- Connect the compressed air.
- Energize the unit.
- Dispose of the used filter cartridges in accordance with federal, state or local regulations.
- Clean the environment of the unit.

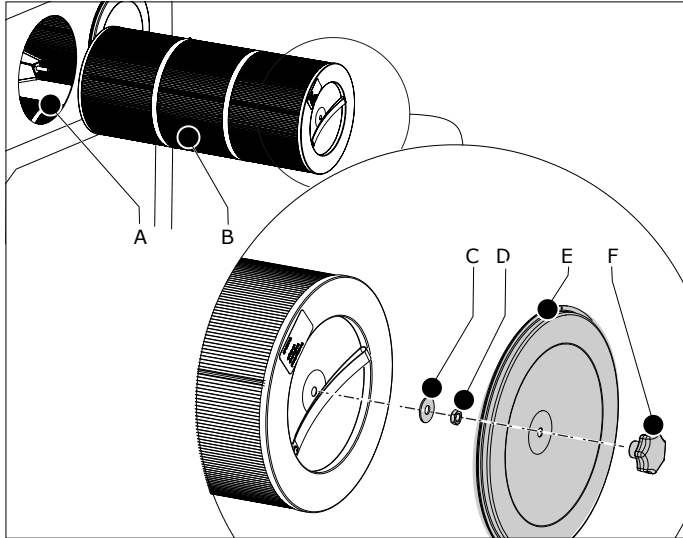

Fig. 7.2 Filter replacement

To clean the inside of the air inlet module, do the following.

- Loosen the 6 bolts of one or both inspection covers.
- Remove the inspection cover(s).
- Clean the inside of the module, preferably with an industrial vacuum cleaner and a non-aggressive detergent.
- Install the inspection cover(s).

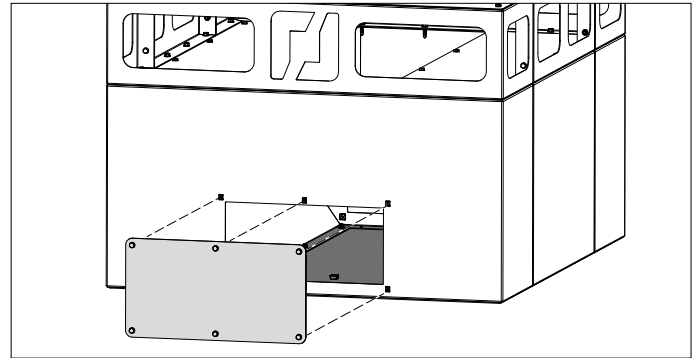

Fig. 7.3 Inspection cover (1 of 2)

## 8 TROUBLESHOOTING

If the system does not function (correctly), consult the checklist below to see if you can remedy the error yourself. Should this not be possible, contact your supplier.



### WARNING

If applicable, put the Panel in the Service Mode before you do the activities as stated below; refer to Fig. 6.1I.

**ATTENTION**

Make sure that the front of the filter cartridge aligns\*) with the filter housing, so that the lid closes well. If this is not the case, the filter cartridge is not positioned correctly. This can cause leakage and less efficient operation of the filter cartridge.

\*) tolerance: max. 2 mm (0.1 in.)

>2 mm

max. 2 mm

Finally:

- Follow the instructions on the HMI.

### 7.4 Cleaning of the air inlet module



For cleaning purposes, the air inlet module is provided with an inspection cover on the front and one on the back side. Depending on the mounting position of the MDB-Diluter, you can use one or both inspection covers.

**Personal protective equipment (PPE)**

Always wear face mask and gloves when you clean the air inlet module.

### 8.1 MDB-Diluter

Symptom	Problem	Possible cause	Solution
Dust or fume from outlet nozzles	Pollution of the facility	Filter cartridge(s) damaged or installed incorrectly	Change filter cartridge(s) or install them correctly
Low airflow or noisy fan	System not working properly	Rotation direction of the fan is wrong	Follow the arrow on the fan housing and check if impeller direction matches the indicator. If not, change motor direction by inverting motor phases between frequency inverter and motor (ref. par. 5.2)
After installation, fan runs at full speed only (50 Hz)	The system ignores the PID setpoint	The fan pressure sensor is not correctly installed	Install the fan pressure sensor correctly (ref. par. 4.10.2)
Motor error ("motor failure")	System not working	Fan wheel blocked	Unblock the fan wheel
		The PTC cable is not (correctly) installed	Repair the connection of the PTC cable (ref. par. 4.12.2)



Symptom	Problem	Possible cause	Solution
Poor extraction capacity	No filter cleaning	Loose compressed air connection	Repair the compressed air connection
		No compressed air available or air pressure too low	Repair the compressed air supply
		Membrane valve(s) defective	Replace the membrane valve(s)
	No pressure in the compressed air tank	Drain valve is loose	Tighten the drain valve
		Tank not connected to compressed air supply	Repair the compressed air connection
Hissing sound	No filter cleaning	Membrane valve(s) defective or worn	Replace the membrane valve(s)
		Wrong or damaged wiring	Correct or repair the wiring
System vibrates at certain frequencies	Noise nuisance	Depending on the length of the duct the unit might have the same frequency as the imposed fan frequency	Contact your supplier
Malfunction of the system	System not working properly	Wrong parameter settings in the frequency inverter	Contact your supplier

## 8.2 Panel

Symptom	Problem	Possible cause	Solution
<b>Panel</b>			
Yellow WARNING LED is on (with or without buzzer)	Refer to HMI	Refer to HMI; for more info, refer to the online user manual	Refer to HMI
Red ALARM LED is on + buzzer	Fan stops		
	Filter cleaning stops		
USB stick is not recognized	Firmware update not possible	USB-stick does not comply with USB 2.0 standard (too slow)	Use a USB 2.0 or USB 3.0 stick

## 8.3 HMI

Symptom	Problem	Possible cause	Solution
HMI screen is locked	No control on HMI possible	Panel is in service mode	Put the switch inside the Panel to 0 (refer to Fig. 6.1 I)
		HMI is in lock mode	Enter PIN and unlock the Homescreen

Symptom	Problem	Possible cause	Solution
Black screen	HMI does not function	Loose connection	Tighten the HMI cable to the CAN connector (refer to Fig. 4.41B+C)
		Loose or incorrectly connected cable	Connect the HMI cable to the CAN HMI connector (refer to Fig. 4.49)
No installation wizard at start up	Configuration of the system not possible	System configured in an earlier stage	Direct to screen <b>5.8</b> to restart the wizard manually
			If necessary: reset PIN (refer to online user manual)
System does not start (white LED is off)	System does not function	No mains voltage	Connect the mains voltage
		Main switch is off	Turn the main switch to on (refer to Fig. 6.1F)
White LED remains off	No indication	LED is defective	Replace the LED
Filter and/or fan pressure value = 0 when system is on	No pressure indication	Loose pneumatic hose(s)	Connect the hose(s)
Filter and/or fan pressure value $\neq$ 0 when system is off	Wrong pressure indication	Wrong pressure setting	Do a zero point calibration of the internal sensors (refer to screen 1.2)
Filter pressure value is negative or illogical	Wrong pressure indication	One pneumatic hose is loose	Connect the hose
		Inverted connection of the pneumatic hoses (+ vs. -)	Correct the connection (refer to par. 4.10.1)
		Wrong type of external pressure sensor configured (PT-1000 vs. PT-2500)	Set the correct type of pressure sensor (refer to screen 1.2)
Malfunction of frequency inverter	Fan pressure value is negative	Wrong connection of the pneumatic hose (+ vs. -)	Correct the connection (refer to par. 4.10.2)
USB stick is not recognized	Firmware update not possible	USB-stick does not comply with USB 2.0 standard (too slow)	Use a USB 2.0 or USB 3.0 stick



For more troubleshooting refer to the HMI.

## 9 SPARE PARTS

The following spare parts are available for the product.



### 9.1 MDB-Diluter

Refer to exploded view Fig. VII on page 29.

### 9.2 Panel

Refer to exploded view Fig. VIII on page 30.

### 9.3 HMI

Refer to exploded view Fig. IX on page 30.

- EN-IEC 61000-6-4:2007 | Electromagnetic compatibility (EMC) - Part 6-4: Generic standards - Emission standard for industrial environments

Alkmaar, Netherlands, 1 March 2019



Jeroen Crezee  
Manager R&D

An **installation** is defined as a combination of several finished products or components that are assembled by an installer at a given place. The various parts of the installation are intended to operate together in a particular environment and to perform a specific task. The entire installation must comply with the relevant directives and standards. The assembly instructions given by the manufacturer, as well as the whole method of installation, must be in accordance with good engineering practices within the context of installations, as well as installation rules. Considering the above, the installer will be responsible for completing the installation and issuing the final CE Declaration of Conformity.

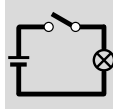

## 10 ELECTRICAL DIAGRAM

Refer to the separately supplied electrical diagram.



## 11 DISPOSAL



		<b>Personal protective equipment (PPE)</b> Wear respiratory protection and protective gloves when you dismantle and dispose of the unit.
--	---	---

### 11.1 Dismantling

To safely dismantle the filter system, obey the safety instructions that follow.

Before dismantling of the system:

- disconnect it from the mains
- disconnect it from the compressed air
- clean the outside

During dismantling of the system:

- make sure that the area is sufficiently ventilated, e.g. by a mobile ventilation unit

After dismantling of the system:

- clean the dismantling area

### 11.2 Disposal

Dispose of the pollutants and dust, together with the used filter cartridges, in a professional manner in accordance with federal, state or local regulations.

## CE DECLARATION

### CE Declaration of Conformity for machinery



We, Plymovent Manufacturing B.V., Koraalstraat 9, 1812 RK Alkmaar, the Netherlands, herewith declare, on our own responsibility, that the product:  
- MDB-Diluter PRO (incl. Panel and HMI)

which this declaration refers to, is in accordance with the conditions of the following:

Directives:

- Machine Directive 2006/42 EC
- LVD 2014/35 EU | Low Voltage Directive

Harmonised Standards:

- EN-IEC 60204-1:2006 | Safety of machinery - Electrical equipment of machines - Part 1: General requirements
- EN-IEC 61439-1:2011 | Low-voltage switchgear and controlgear assemblies - Part 1: General rules
- EN-IEC 61131-2:2007 | Programmable controllers - Part 2: Equipment requirements and tests
- EN-IEC 61000-6-2:2005 | Electromagnetic compatibility (EMC) - Part 6-2: Generic standards - Immunity for industrial environments

Fig. I Dimensions MDB-Diluter

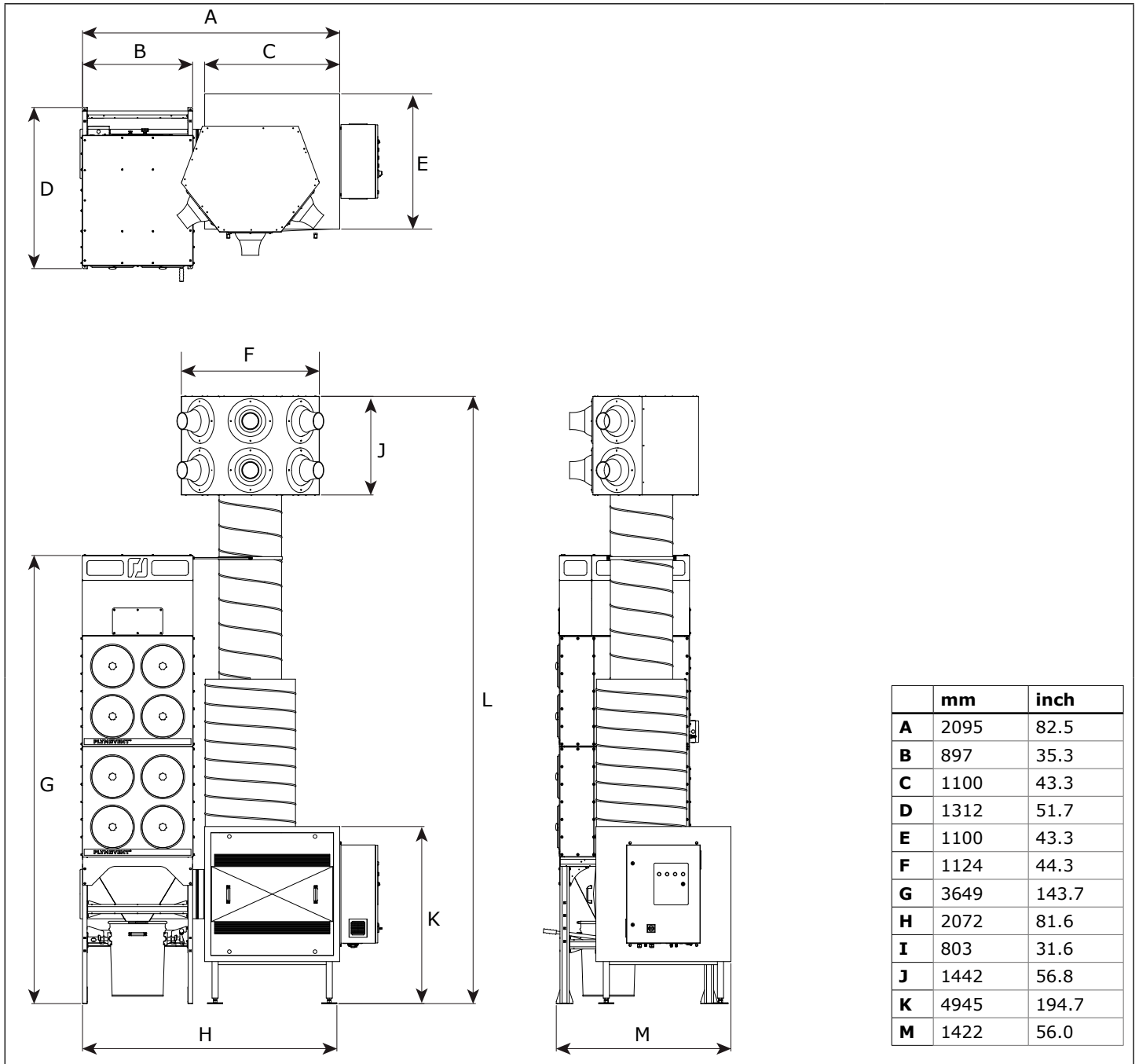

Fig. II Dimensions Panel

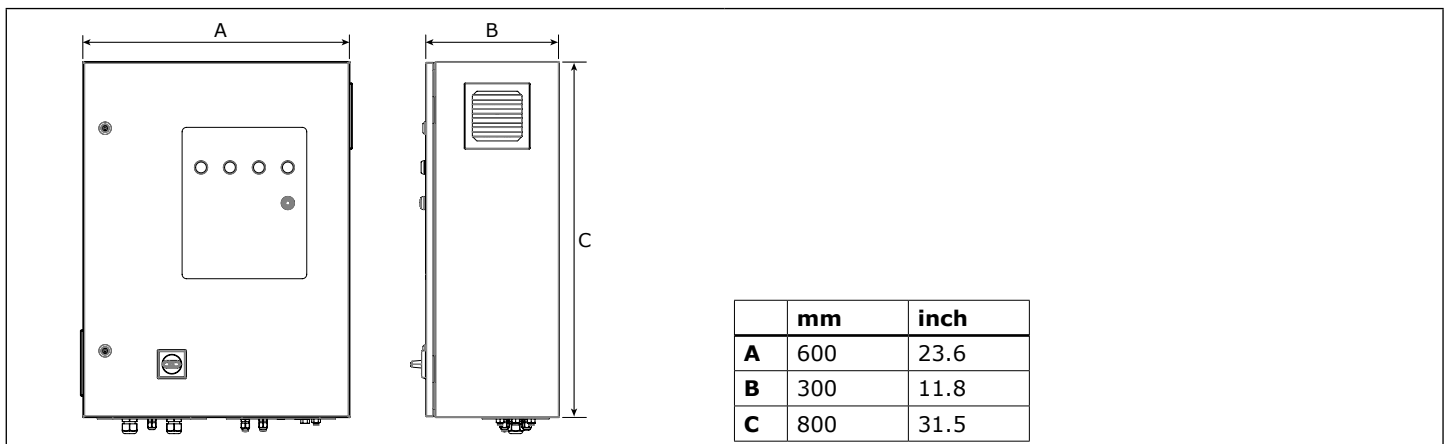

Fig. III Air circulation

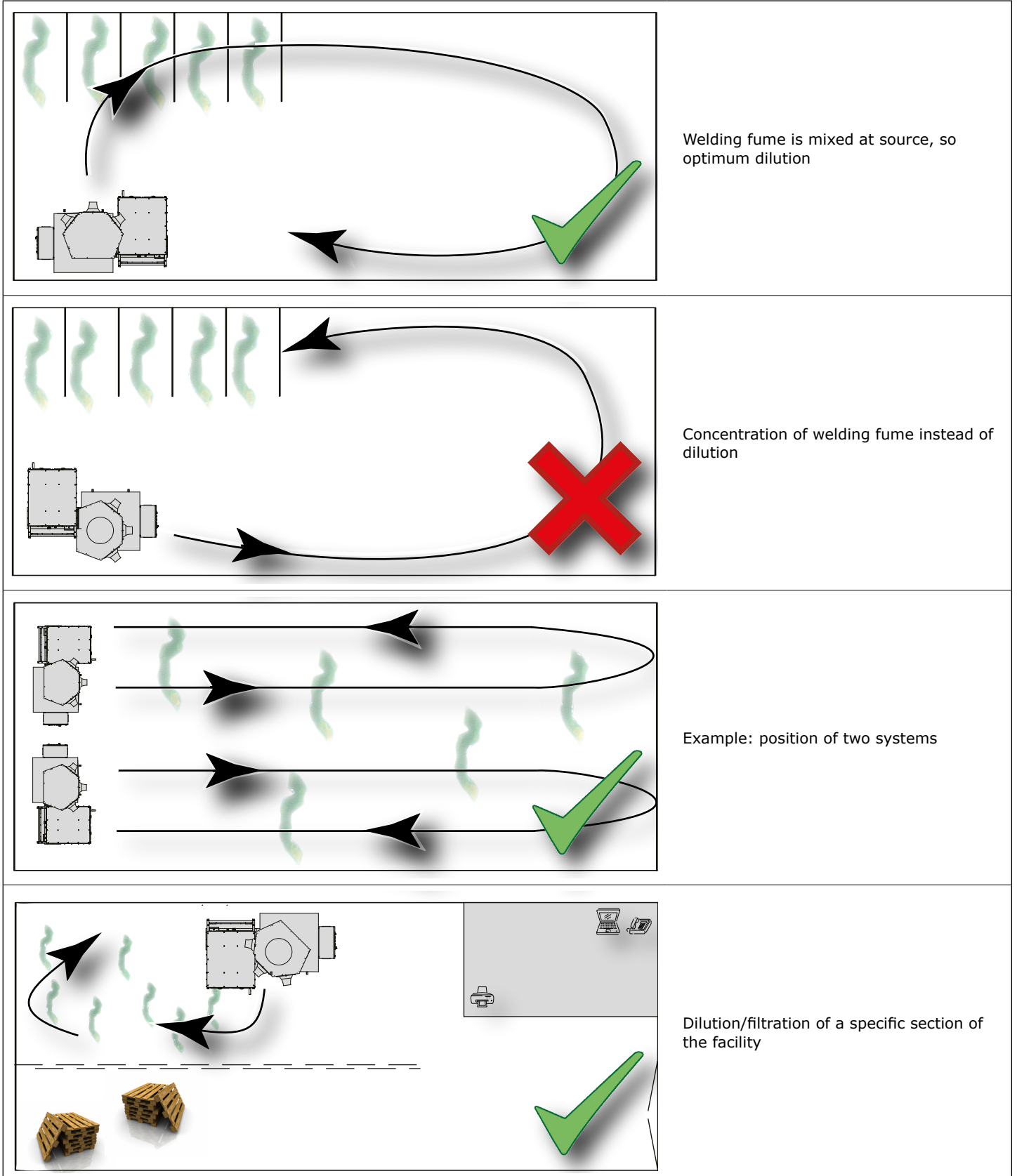

Fig. IV Overview of pneumatic and electric connections

Ref. / Cable #		E = Electric P = Pneumatic	For connection of:	To:
1	Panel → HMI	E	Panel	HMI
5	Mains cord	E	Panel	Mains
20	Control cable	E	Compressed air switch	Panel
23	Motor cable	E	Fan motor	Panel (frequency inverter)
24	PTC cable	E		
A	Pneumatic hose	P	Compressed air switch (via optional regulator)	Compressed air supply
B	Filter pressure tube (+)	P	Filter module	Panel (push-in fittings)
C	Filter pressure tube (-)	P		
D	Fan pressure tube (+)	P	Panel	Vertical duct

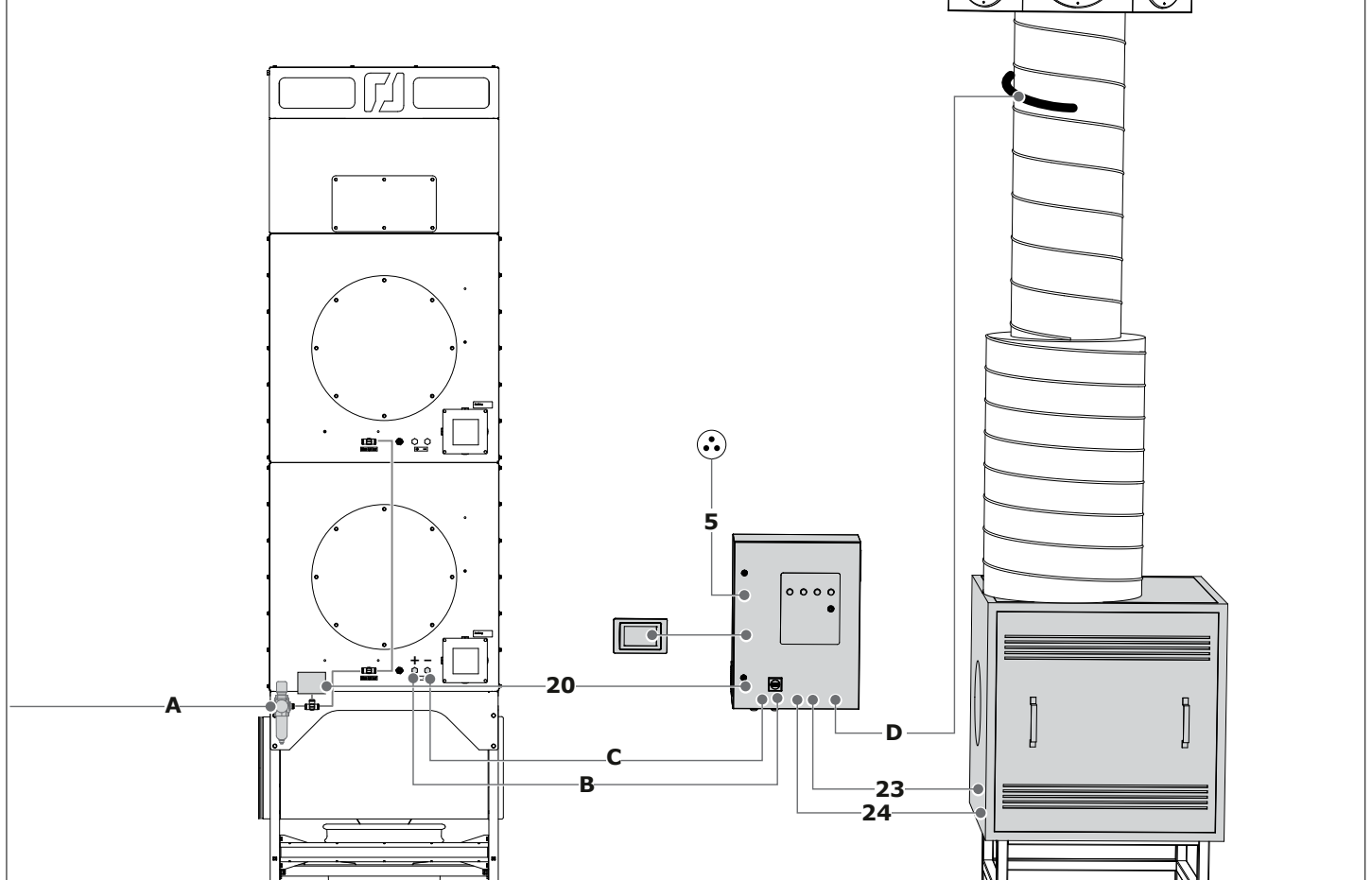

Fig. V Control panel

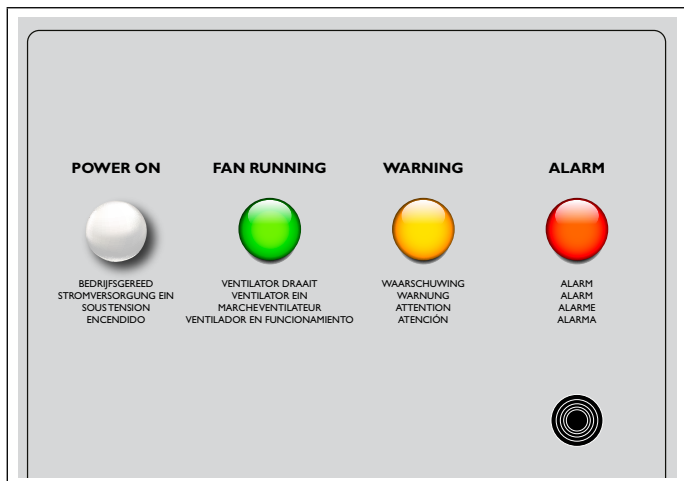

Fig. VI Labyrinth-shaped spark arrester

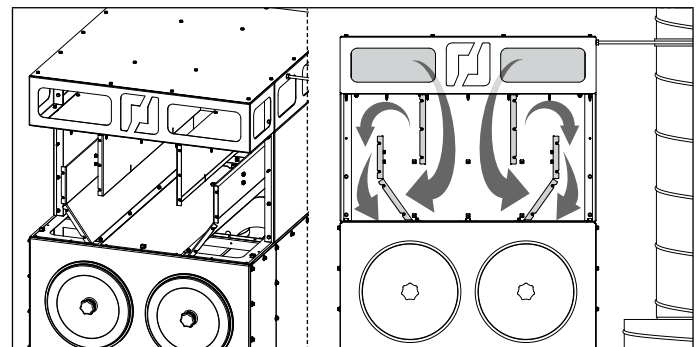
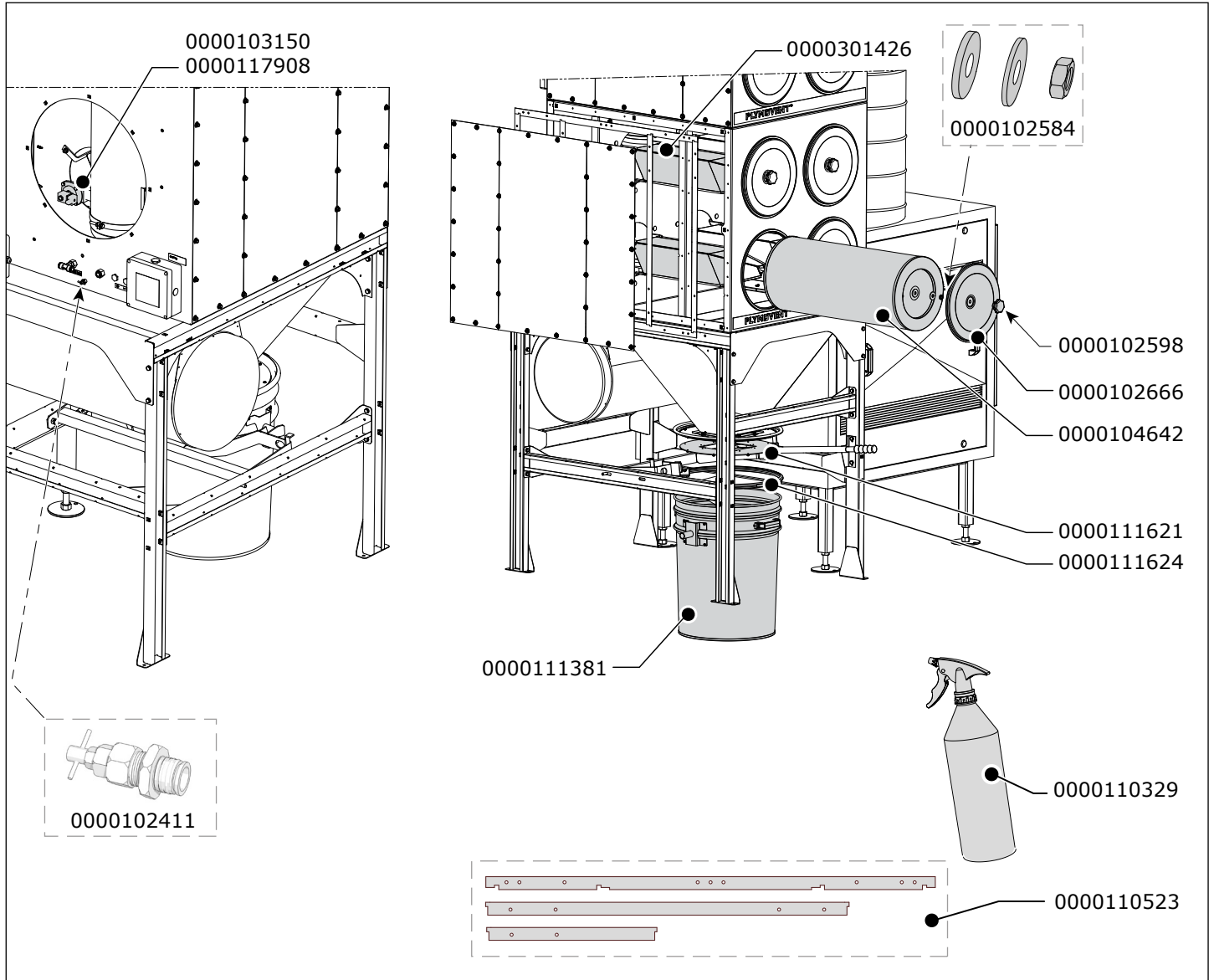

Fig. VII MDB-Diluter



Art. no.	Description
<b>Filter system MDB-Diluter</b>	
0000102411	Drain valve 1/2 inch
0000102584	Lock kit for CART filter cartridge
0000102598	Star knob M12
0000102666	Lid for filter cartridge CART (MDB)
0000103150	Magnetic valve 1 inch, incl. 24V DC coil and 3 m cable
0000104642	CART-PTFE/15 / Filter cartridge
0000110329	SealApplicator
0000110523	Spare seal set MDB
0000111381	DB-80 / Dustbin 80 litres, incl. lifting pin and handles
0000111621	Lid for connection of DB-80 to HOPPER
0000111624	Clamp ring for dustbin DB-80
0000117908	Membrane (square) + spring for magnetic valve
0000301426	Filter cartridge holder MDB

Art. no.	Description
<b>Fan SIF-1200</b>	
0000102363	Fan wheel SIF-1200
0321300140	Motor SIF-1200; 400-690V/3ph/50Hz

Fig. VIII Panel

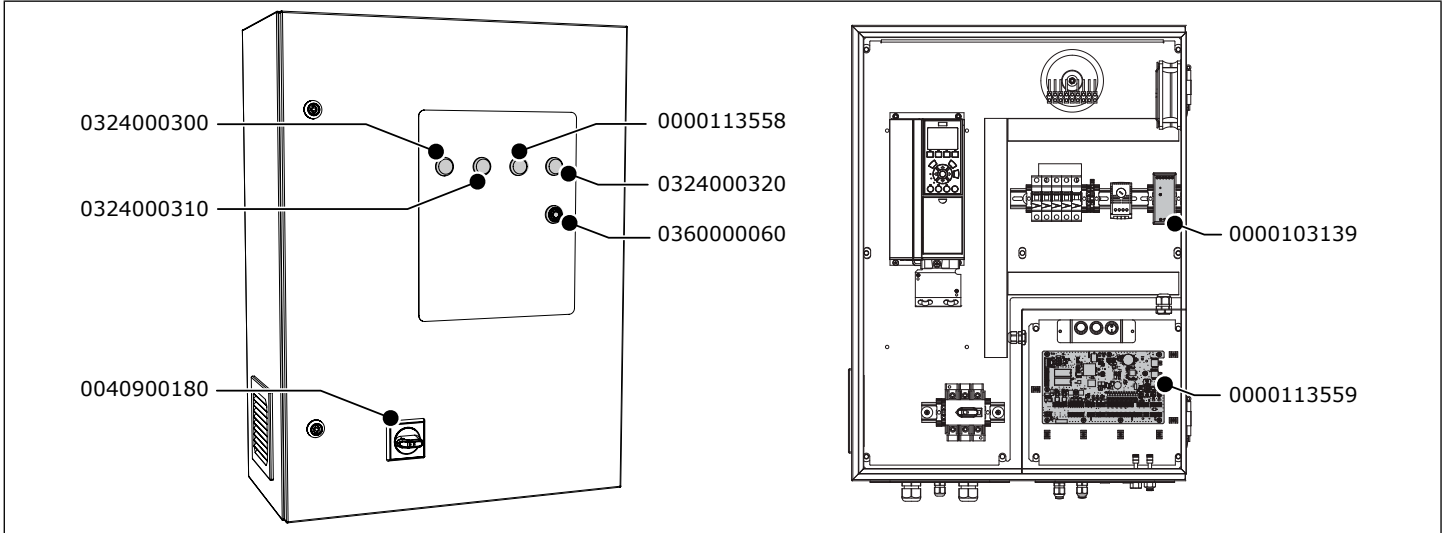

Art. no.	Description
<b>Panel</b>	
0000103139	Switch mode power supply 24V DC 2.5A
0000113558	Indicator light yellow 24V
0000113559	PCB main board ControlPro
0324000300	Indicator light white 24V
0324000310	Indicator light green 24V
0324000320	Indicator light red 24V
0360000060	Buzzer

Fig. IX HMI

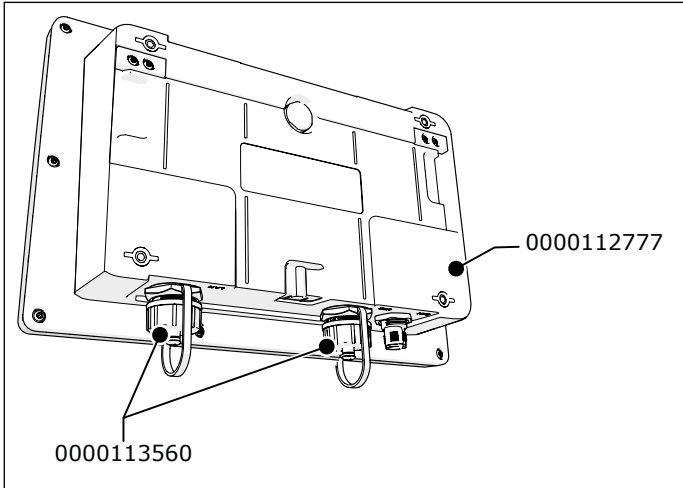

Art. no.	Description
<b>HMI</b>	
0000112777	ControlPro/HMI (complete)
0000113560	Dust cap for ControlPro/HMI

Fig. X Velocity, throw and air volume

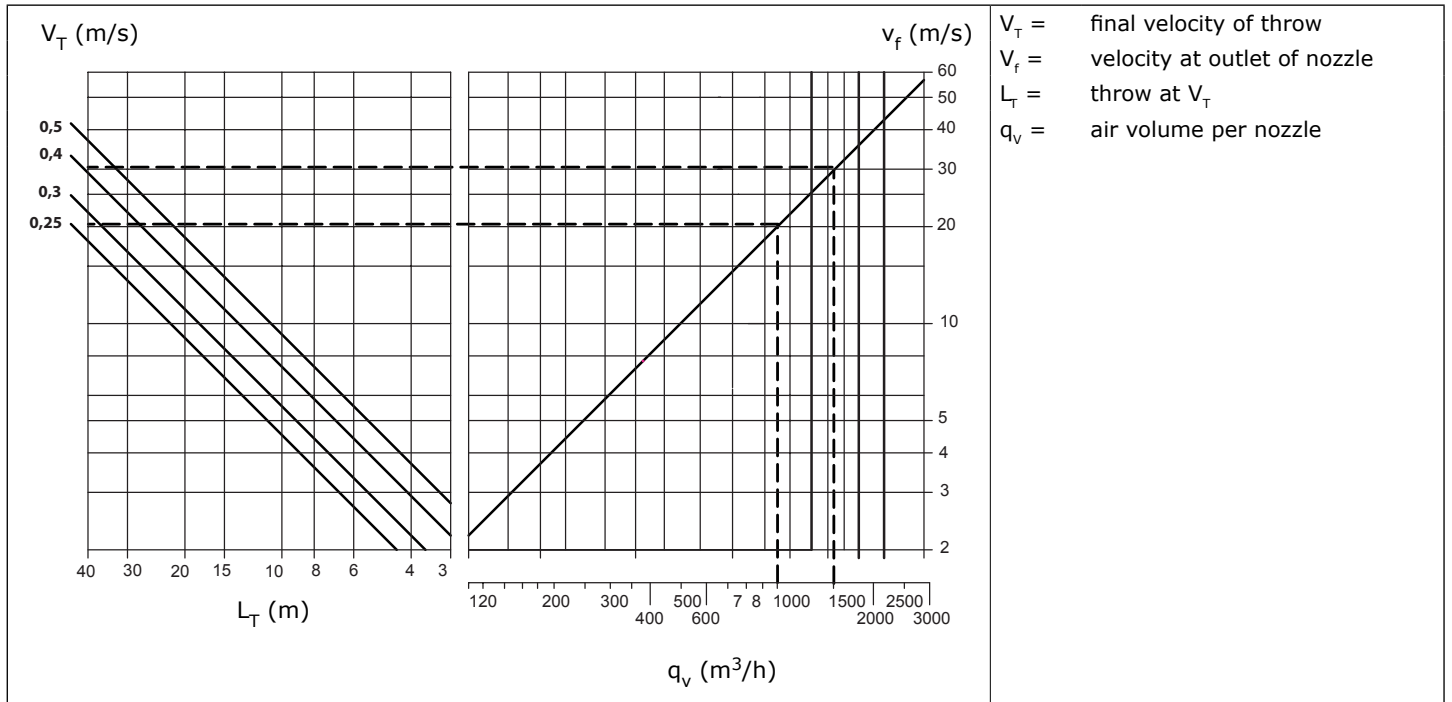

Fig. XI Horizontal throw per nozzle

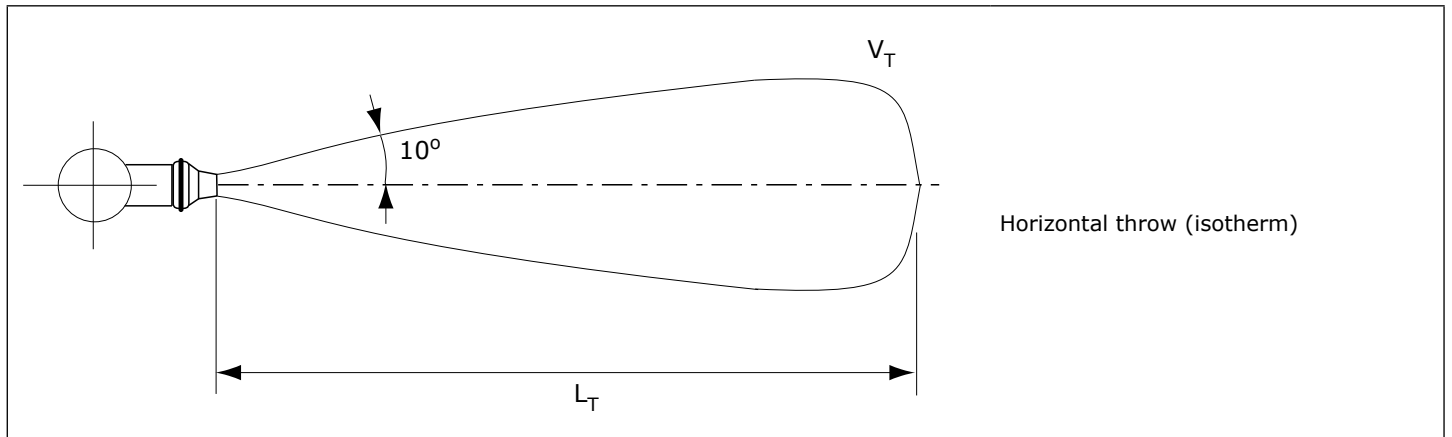



Table I Cable specifications

	Connection	Recommended cable type	Included	Source locally	For use with	Option
<b>#</b>					<b>MDB-Diluter</b>	
1	Panel → HMI (shielded)		✓		✓	
2	Panel → SlaveBoard (shielded)		✓		✓	
3	SlaveBoard → SlaveBoard		✓		✓	
5	Mains cord	H05VV-F 4G4		✓	✓	
6	External start/stop			✓	✓	✓
7	External alert input			✓	✓	✓
8	Relay output 1	H05VV-F 2X0.75		✓	✓	✓
9	Relay output 2			✓	✓	✓
20	Control cable (compressed air switch)		✓ *)		✓	
22	Light tower	H05VV-F 7X0.5		✓	✓	✓
23	Motor cable	190 CY 4X4 (shielded)	✓			
24	PTC cable	190 CY 2X0.75 (shielded)	✓			

\*) connected to compressed air switch

Table II Digital inputs

Input	Input	
	High	Low
IN 5	External signal fan start/stop	
	start	stop
IN 6	Fire alarm	
	normal	alarm
IN 9	Fan alarm	
	alarm	normal
IN 10	Compressed air switch	
	normal	alert
IN 11	External alarm signal	
	normal	alert
IN 12	Dustbin level switch	
	full	not full

