

SFS

STATIONARY UNIT WITH SELF-CLEANING FILTER

The SFS is a wall-mounted filter unit that provides filtration for use with one extraction arm and fan. The SFS features a round filter cartridge. This filter cartridge is provided with a precoat to extend the lifespan and the efficiency of the filter.

The SFS is fitted with a *RoboClean* system for automatic sectionwise cleaning of the filter cartridge by (externally supplied) compressed air. The dust and dirt particles end up in the dust bin. The SFS comes with an external pre filter (spark arrester) in a separate box. The SFS needs to be connected to a control box.



APPLICATIONS

The SFS is intended to be used for the following applications:

- MIG-MAG/GMAW welding (annual use: >700 kg/1500 lbs)
- TIG welding
- FCAW welding (annual use: >700 kg/1500 lbs)
- stick/MMAW welding (annual use: >500 kg/1100 lbs)



Do **not** use the SFS for the following applications or in the following circumstances:

- arc-air gouging
- aluminium laser cutting
- oil mist
- heavy oil mist in welding fume
- extraction of aggressive fumes and gases (e.g. from acids, from alkaline, from soldering paste containing lithium)
- extraction of hot gases (more than 45°C/113°F continuously)
- grinding aluminum and magnesium
- flame spraying
- extraction of cement, saw dust, wood dust etc.
- sucking cigarettes, cigars, oiled tissues and other burning particles, objects and acids
- explosive environments or explosive substances/gases



SPECIFICATIONS

| ■ Physical dimensions and properties | |
|--------------------------------------|----------------------------|
| Material | polypropylene |
| Colour: | |
| • Housing | • grey RAL 7024 |
| • Strip | • yellow RAL 1028 |
| Weight (net) | |
| • SFS | 67 kg (148 lbs) |
| • prefilter box | 10 kg (22 lbs) |
| Supply cable (loose) | 11 m (36 ft); without plug |
| Contents dust bin | 18 litres |

FILTERS

| | |
|---------------------|---|
| Material: | |
| • Pre filter | • aluminium |
| • DuraFilter FCC-30 | • phenol impregnated cellulose + polyurethane + metal |



| | |
|---|---|
| Filter surface area: | |
| • Pre filter | • 0,14 m ² (1.5 ft ²) |
| • DuraFilter FCC-30 | • 30 m ² (325 ft ²) |
| Treatment | SurfacePlus precoat on DuraFilter FCC-30 |
| Efficiency: | |
| • Pre filter | • 65% < 80% |
| • DuraFilter FCC-30 | • > 99,9% |
| Filter class: | |
| • Pre filter | • G2 according to DIN EN 779 |
| • DuraFilter FCC-30 | • M according to NEN EN IEC 60335-2-69 |
| ■ RoboClean filter cleaning system | |
| Required compressed air quality | dry and oil-free according to ISO 8573-3 class 6 |
| Required pressure | 4-5 bar (1600-2000" WG) |
| Compressed air connection | quick connect coupling ¼ in. |
| Compressed air consumption | max. 60 nl/min. (depending on the degree of saturation of the filter) |
| Duration off-line cleaning cycle | approx. 1 hour |
| ■ Performance | |
| Airflow | max. 1100 m ³ /h (647 CFM) |
| ■ Electrical data | |
| Power consumption | 36 W |
| Connection voltage | 24 V AC |
| Protection class | IP 40 |
| ■ Ambient conditions | |
| Operating temperature: | |
| • min. | • 5°C (41°F) |
| • nom. | • 20°C (68°F) |
| • max. | • 45°C (113°F) |
| Max. relative humidity | 80% |
| Outdoor use allowed | no |
| Storage conditions | • 5-45°C (41-113°F) • relative humidity max. 80% |

| | |
|--|--|
| ■ Product combinations | |
| CB (compulsary) | control box |
| <i>For more product combinations, refer to the table "Possible configurations"</i> | |
| ■ Scope of supply | |
| Filter unit - Supply cable 11 m - Mounting plate - Prefilter box | |
| ■ Order information | |
| Article number | 7445000000 |
| Number/package | 1 |
| ■ Shipping data | |
| Gross weight | 81 kg (179 lbs) |
| Packing dimensions | 120 x 80 x 120 cm (47.2 x 31.5 x 47.2 in.) |
| Max. number/pallet | 2 |
| Harmonized Tariff Code | 8421.39.2090 |
| Country of origin | the Netherlands |

POSSIBLE CONFIGURATIONS

| Extraction arm | Wall bracket | Fan | Control equipment (options) |
|----------------|-----------------|--------|-----------------------------|
| T-Flex | TNB | FAN-28 | MPS |
| Flex-2 | | FAN-28 | |
| T-Flex/CW | <i>included</i> | FAN-42 | CB WL NTR |
| Flex-3 | NMB | FAN-28 | CB WL-AST NTR |
| Flex-4 | | FAN-28 | |
| UltraFlex-3 | | FAN-42 | CB-WCS WCS NTR |
| UltraFlex-4 | | | |
| UltraFlex-4/LC | | | |

APPROVALS/CERTIFICATES

| | |
|---|---|
|  | |
|  | Directive 2011/65/EC (RoHS) valid as of 8 June 2011 |

DIMENSIONS

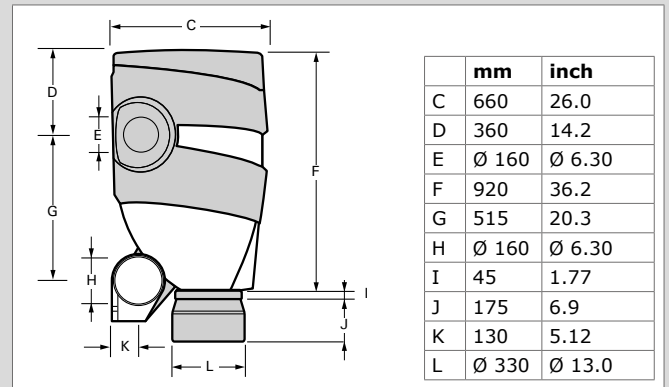
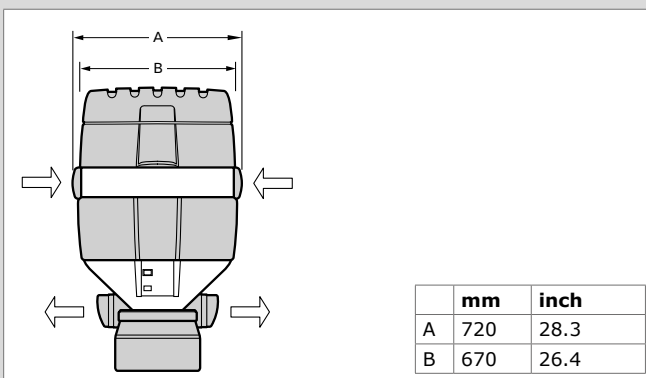

PRESSURE DROP

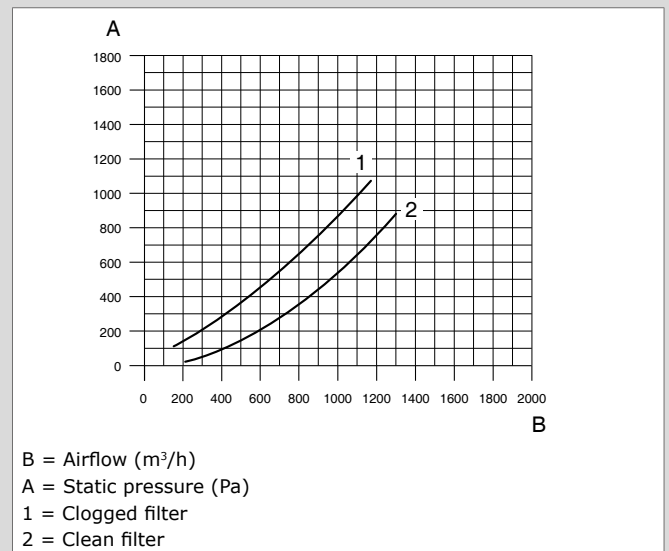

FEATURES

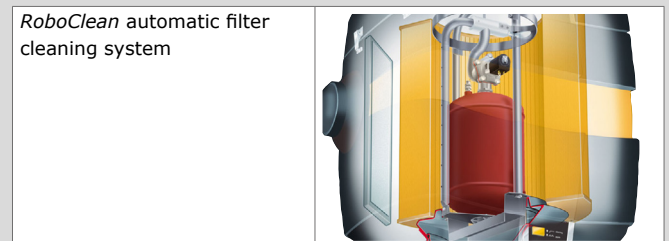

| | |
|------------------|---------------------------------|
| Product type | SFS |
| Article no. | 7445000000 |
| Product category | Stationary welding fume filters |
| Version | 250521/H |

Always check the latest version on www.plymovent.com