

Extraction arm

## KUA-200/H /S /ATEX

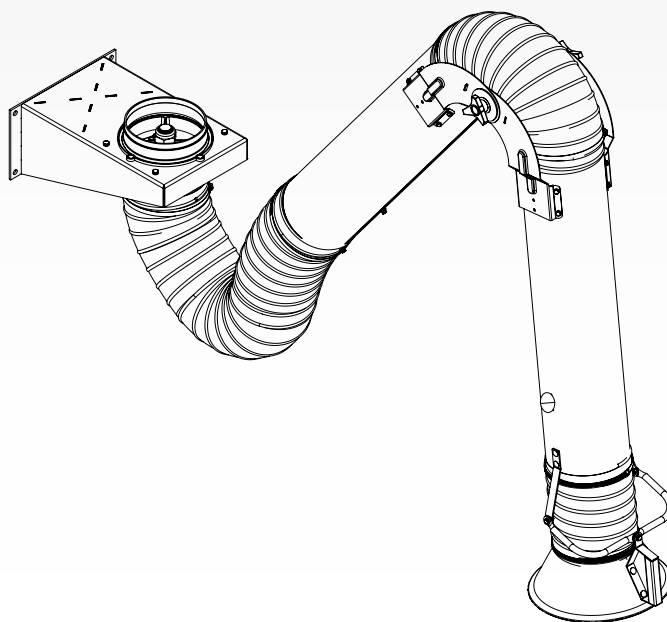

EN

Installation and user manual

---

---

## TABLE OF CONTENTS

PREFACE.....	2
1 INTRODUCTION.....	2
2 PRODUCT DESCRIPTION .....	3
3 SAFETY .....	3
4 INSTALLATION .....	4
5 USE .....	7
6 MAINTENANCE .....	7
7 TROUBLESHOOTING .....	8
8 SPARE PARTS .....	8
9 DISPOSAL .....	8
CE DECLARATION .....	8

### EN | ORIGINAL INSTRUCTION

All rights reserved. The information given in this document has been collected for the general convenience of our clients. It has been based on general data pertaining to construction material properties and working methods known to us at the time of issue of the document and is therefore subject at any time to change or amendment and the right to change or amend is hereby expressly reserved. The instructions in this publication only serve as a guideline for installation, use, maintenance and repair of the product mentioned on the cover page of this document. This publication is to be used for the standard model of the product of the type given on the cover page. Thus the manufacturer cannot be held responsible for any damage resulting from the application of this publication to the version actually delivered to you. This publication has been written with great care. However, the manufacturer cannot be held responsible, either for any errors occurring in this publication or for their consequences.

*To improve comprehension for people whose first language is not English, we have written parts of this manual in Simplified Technical English (STE). STE is a controlled language originally developed for aerospace industry maintenance manuals. It offers a carefully limited and standardized subset of English, along with specific writing rules.*









## PREFACE

### Using this manual

This manual is intended to be used as a work of reference for professional, well trained and authorised users to be able to safely install, use, maintain and repair the product mentioned on the cover of this document.

### Pictograms and symbols

The following pictograms and symbols are used in this manual:

	<b>TIP</b> Suggestions and recommendations to simplify carrying out tasks and actions.
	<b>ATTENTION</b> A remark with additional information for the user. A remark brings possible problems to the user's attention.
	<b>CAUTION!</b> Procedures, if not carried out with the necessary caution, could damage the product, the workshop or the environment.
	<b>WARNING!</b> Procedures which, if not carried out with the necessary caution, may damage the product or cause serious personal injury.
	<b>WARNING!</b> Fire hazard! Important warning to prevent fire.
	<b>WARNING!</b> Explosion hazard! Important warning to prevent explosions.
	<b>Personal protective equipment (PPE)</b> Instruction to use respiratory protection when you do service, maintenance and repair jobs, as well as during functional testing. We recommend to use a half-face respirator according to EN 149:2001 + A1:2009, class FFP3 (Directive 89/686/EEC).
	<b>Personal protective equipment (PPE)</b> Instruction to use protective gloves when you do service, maintenance and repair jobs.

### Text indicators

Listings indicated by "-" (hyphen) concern enumerations. Listings indicated by "•" (bullet point) describe steps to perform.

## 1 INTRODUCTION

### 1.1 Identification of the product

The identification plate contains, among other things, the following data:

- product name
- serial number

### 1.2 General description

The KUA-200 is an extraction arm with an external middle hinge. The removable hood has a safety mesh. The arm is fitted with a sealed shut-off & control valve and is 360° rotatable. The hood is 85° movable in four directions.

The KUA-200 arm is available in three different types:  
- type **H**: for hanging mounting (wall bracket included)  
- type **S**: for standing mounting<sup>1</sup>

- type **ATEX**: approved for use in explosive environments Zone 22; marking EX II 3D (for hanging mounting only)<sup>2</sup>

### 1.3 Options and accessories

#### Arm-fan adapter

for connection of the KUA-200 with a fan<sup>3</sup>

### 1.4 Product combinations

You can use the KUA-200 with the following products:

#### Extraction fan

- FUA-1800 | 0,55 kW (0.75 HP)
- FUA-2100 | 0,75 kW (1 HP)
- FUA-3000 | 1,1 kW (1.5 HP)

#### Extension crane

- FlexMax-15/200 | 1,5 m (5 ft)
- FlexMax-25/200 | 2,5 m (8.2 ft)
- FlexMax-35/200 | 3,5 m (11.5 ft)
- FlexMax-45/200 | 4,5 m (15 ft)

#### Stanchion

- PA-110/200 | 1,1 m (3.6 ft)
- PA-220/200 | 2,2 m (7.2 ft)

### 1.5 Technical specifications

Physical dimensions and properties	
Length:	
- KUA-200/3	- 3 m (9.8 ft)
- KUA-200/4	- 4 m (13.1 ft)
Diameter:	
- tubes	- Ø 200 mm (7.9 in.)
- hood opening	- Ø 340 mm (13.4 in.)
Material of tubes	aluminium
Material of hoses:	
- type <b>H</b> and <b>S</b>	- PVC with spring steel wire
- type <b>ATEX</b>	- polyethylene with copper coated spring steel wire
Weight:	
- KUA-200/3	- 34 kg (75 lbs.)
- KUA-200/4	- 36 kg (79 lbs.)
- wall bracket ( <b>H</b> types)	- 5 kg (11 lbs.)
Performance	
Recommended airflow	max. 1600 m <sup>3</sup> /h (940 CFM)

### 1.6 Working reach

Refer to Fig. I on page 9.

### 1.7 Pressure drop

Refer to Fig. II on page 10.

	Refer to the available product data sheet for detailed product specifications.
---	--

### 1.8 Ambient and process conditions

Process temperature:	
- min.	- 5°C (41°F)
- nom.	- 20°C (68°F)
- max.	- 70°C (158°F)
Max. relative humidity	90%
Outdoor use allowed	no

1. Future development

2. In accordance with TRGS 727 & ATEX Directive 2014/34/EU

3. Suitable types: FUA-1800 | FUA-2100 | FUA-3000

## 2 PRODUCT DESCRIPTION

### 2.1 Components

The product consists of the following main components and elements:

Fig. 2.1

- A Wall bracket<sup>4</sup>
- B Rotating hinge
- C Connection flange
- D Inner tube
- E Middle hinge
- F Outer tube
- G Hose
- H Shut-off & control valve
- I Hood

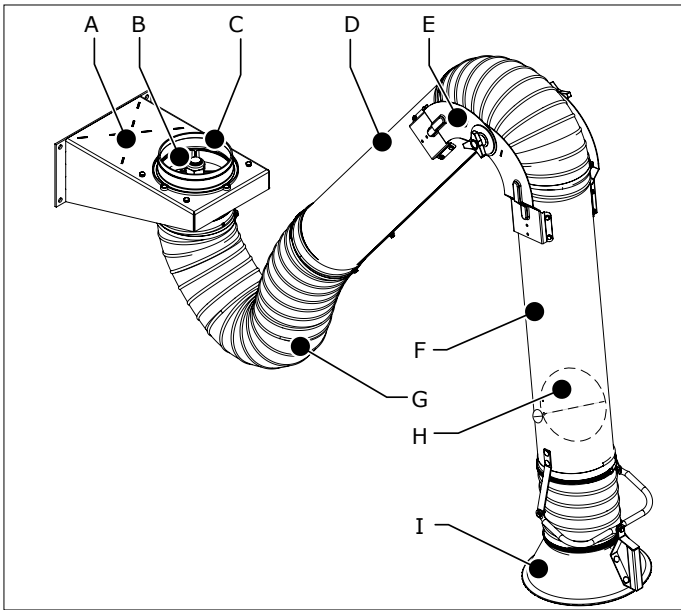

Fig. 2.1 Main components and elements

### 2.2 Operation

The welding fume is extracted through the hood of the arm by a single or central fan. The extraction arm discharges the polluted air to an extraction duct with filter unit or directly to the atmosphere.

The arm is fitted with a valve to shut off or regulate the airflow. The shut-off valve is mostly used when several extraction arms are integrated in a line installation; in such configurations closing the valve prevents the loss of costly heated air.

## 3 SAFETY

### General

The manufacturer does not accept any liability for damage to the product or personal injury caused by ignoring of the safety instructions in this manual, or by negligence during installation, use, maintenance, and repair of the product mentioned on the cover of this document and any corresponding accessories. Specific working conditions or used accessories may require additional safety instructions. Immediately contact your supplier if you detect a potential danger when using the product.



**The user of the product is always fully responsible for observing the local safety instructions and**

4. Not applicable for **S** types

**regulations. Observe all applicable safety instructions and regulations.**

### User manual

- Everyone working on or with the product, must be familiar with the contents of this manual and must strictly observe the instructions therein. The management should instruct the personnel in accordance with the manual and observe all instructions and directions given.
- Do not change the order of the steps to perform.
- Keep the manual with the product.

### Users

- The use of this product is exclusively reserved to authorised, trained and qualified users. Temporary personnel and personnel in training can only use the product under supervision and responsibility of skilled engineers.
- Stay alert and keep your attention to your work. Do not use the product when you are under the influence of drugs, alcohol or medicine.
- The product is not to be used by children or persons with reduced physical, sensory or mental capabilities, or lack of experience and knowledge, unless they have been given supervision or instruction.
- Children must be supervised not to play with the product.

### Intended use<sup>5</sup>

The product has been designed exclusively for extracting fumes and particles which are released during the most common welding and cutting processes. Using the product for other purposes is considered contrary to its intended use. The manufacturer accepts no liability for any damage or injury resulting from such use. The product has been built in accordance with state-of-the-art standards and recognised safety regulations. Only use this product when in technically perfect condition in accordance with its intended use and the instructions explained in the user manual.

### Technical specifications

Do not change the specifications given in this manual.

### Modifications

Modification of (parts of) the product is not allowed.

### Product combinations

If the product is used in combination with other products or machines, the safety instructions in the documentation of these products also apply.



### Installation

- The installation of this product is exclusively reserved to authorised, trained and qualified engineers.
- During installation, always use Personal Protective Equipment (PPE) to avoid injury. This also applies to persons who enter the work area during installation.
- Use sufficient climbing gear and safety guards when working on a higher level than 2 metres (local restrictions may apply).
- Do not install the product in front of entrances and exits which must be used for emergency services.
- Mind any gas and water pipes and electric cables.
- Make sure that the workspace is well illuminated.

5. "Intended use" as explained in EN-ISO 12100-1 is the use for which the technical product is suited as specified by the manufacturer, inclusive of his directions in the sales brochure. In case of doubt it is the use which can be deduced from the construction, the model and the function of the technical product which is considered normal use. Operating the machine within the limits of its intended use also involves observing the instructions in the user manual.

- Stay alert and keep your attention to your work. Do not install the product when you are under the influence of drugs, alcohol or medicine.
- Air containing particles such as chromium, nickel, beryllium, cadmium, lead etc., should never be recycled. This air must always be brought outside the working area.

## Use



	<p><b>WARNING!</b> Fire hazard! Do <b>not</b> use the product for:</p> <ul style="list-style-type: none"> <li>- polishing applications in combination with grinding, welding or any other application that generate sparks (fibers from polishing or abrasive flap disks are highly flammable and pose a high risk of filter fires when exposed to sparks)</li> <li>- arc-air gouging</li> <li>- extracting flammable, glowing or burning particles or solids or liquids</li> <li>- extracting of aggressive fumes (such as hydrochloric acid) or sharp particles</li> <li>- extracting dust particles which are released when welding surfaces treated with primer</li> <li>- sucking cigarettes, cigars, oiled tissues, and other burning particles, objects, and acids</li> </ul>
	<p><b>WARNING!</b> Explosion hazard! Do <b>not</b> use the product for explosion-hazardous applications, e.g.:</p> <ul style="list-style-type: none"> <li>- aluminium laser cutting</li> <li>- grinding aluminium and magnesium</li> <li>- explosive environments or explosive substances/gases</li> </ul>
	<p><b>WARNING!</b> Do <b>not</b> use the product for:</p> <ul style="list-style-type: none"> <li>- extraction of hot gases (more than 70°C/158°F continuously)</li> <li>- flame spraying</li> <li>- oil mist</li> <li>- heavy oil mist in welding fume</li> <li>- extraction of cement, saw dust, wood dust etc.</li> </ul>

- Inspect the product and check it for damage. Verify the functioning of the safety features.
- During use, always use Personal Protective Equipment (PPE) to avoid injury. This also applies for persons who enter the work area.
- Check the working environment. Do not allow unauthorised persons to enter the working environment.
- Protect the product against water and humidity.
- Make sure the room is always sufficiently ventilated; this applies especially to confined spaces.
- Make sure that the workshop, in the vicinity of the product, contains sufficient approved fire extinguishers (suitable for fire classes ABC).

## Service, maintenance and repairs

- Obey the maintenance intervals given in this manual. Overdue maintenance can lead to high costs for repair and revisions and can render the guarantee null and void.
- Always use Personal Protective Equipment (PPE) to avoid injury. This also applies for persons who enter the work area.
- Make sure the room is sufficiently ventilated.
- Use tools, materials, lubricants and service techniques which have been approved by the manufacturer. Never use worn tools and do not leave any tools in or on the product.

- Safety features which have been removed for service, maintenance or repairs, must be put back immediately after finishing these jobs and it must be checked that they still function properly.
- Use sufficient climbing gear and safety guards when working on a higher level than 2 metres (local restrictions may apply).
- Clean the area afterwards.

	<p><b>ATTENTION</b> Service, maintenance and repairs must be performed in accordance with directive TRGS 560 and TRGS 528 by authorised, qualified and trained persons (skilled) using appropriate work practices.</p>
	<p><b>Personal protective equipment (PPE)</b> Wear respiratory protection and protective gloves during service, maintenance and repairs.</p>

## 4 INSTALLATION

### 4.1 Tools and requirements

You need the following tools and requirements to install the product:

- basic tools



### 4.2 To be sourced locally

You need the following material to install the product:

- wall mounting hardware<sup>6</sup>



### 4.3 Unpacking

Make sure that the product is complete. The package contains:

- semi-assembled arm, incl. hoses
- hood
- rotating hinge
- wall bracket<sup>7</sup>
- aluminium collar
- rubber collar (6)
- hose clamp (6)
- mounting material



If parts are missing or damaged, contact your supplier.

### 4.4 Installation height

Refer to Fig. 4.2C.

### 4.5 Wall mounting

	<p><b>FlexMax   Extension crane</b> To install the KUA-200 on an extension crane, refer to the instruction sheet that is supplied with the FlexMax.</p>
	<p><b>PA   Stanchion</b> To install the KUA-200 on a stanchion, refer to the instruction sheet that is supplied with the PA.</p>

The package contains no mounting hardware for the wall bracket, since the required mounting hardware depends on the wall type. The wall bracket can be mounted on e.g.:

- a thin brick or concrete wall (min. thickness 100 mm), using four threaded rods M10;
- a thick brick or concrete wall, using four cotter bolts M10x120x60;

6. The type of hardware depends on the wall type

7. H types only

- a steel profile (e.g. H-profile), using four threaded rods M10. For this purpose two square tubes (30x30x3 mm) need to be mounted to prevent bending.



**WARNING!**

Before you install the product, make sure that the wall or mounting structure is strong enough. Refer to paragraph 1.5 for the weight of the product.

**4.5.1 Rotating hinge**

Fig. 4.1

- Install the rotating hinge (A) on the wall bracket on the 4 corner positions. Make sure that the position of the rotating hinge is correct (B = wall side).

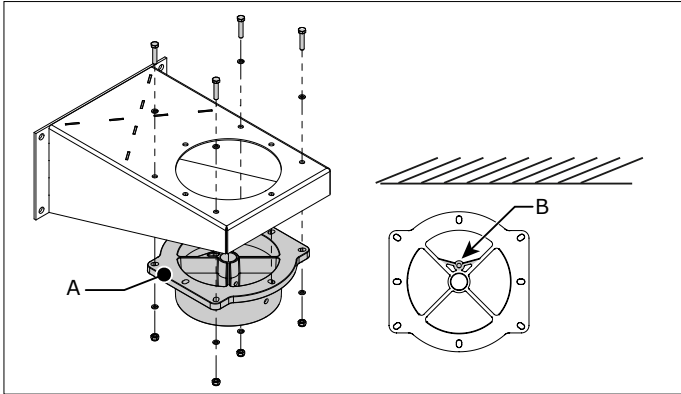
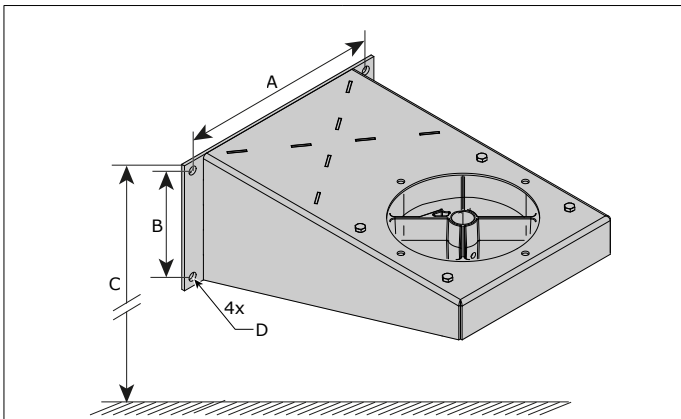

Fig. 4.1 Mounting of the rotating hinge

**4.5.2 Wall bracket**

Fig. 4.2

- Install the wall bracket to the wall or mounting structure.



	mm	in.
<b>A</b>	320	12.6
<b>B</b>	170	6.7

	m	ft
<b>C</b>	2 - 2,3	6.5 - 7.5

	mm	F
<b>D</b>	Ø 13	9000 N

Fig. 4.2 Mounting of the wall bracket

**4.5.3 Aluminium collar**

Fig. 4.3

- Put the collar (D) over the hinge rod (C) of the arm.
- Put the clamping pin (B) through the collar and the hinge rod.
- Lock the clamping pin at the outside of the collar with 2 capped push-on fasteners (Starlock) (A+E).

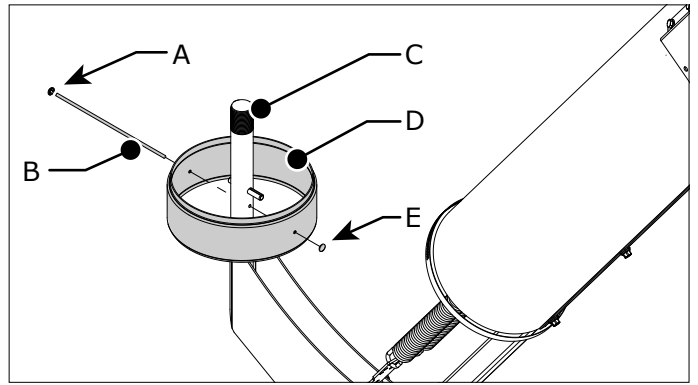

Fig. 4.3 Mounting of the aluminium collar

**4.5.4 Hinge rod**

Fig. 4.4

- Put a shim ring (D) on the hinge rod (E) and put the hinge rod into the rotating hinge (C).
- Put another shim ring (B) on top of the hinge rod.
- Put the nut M30 (A) on the hinge rod. Fasten the nut, but make sure that the hinge rod can still easily turn.

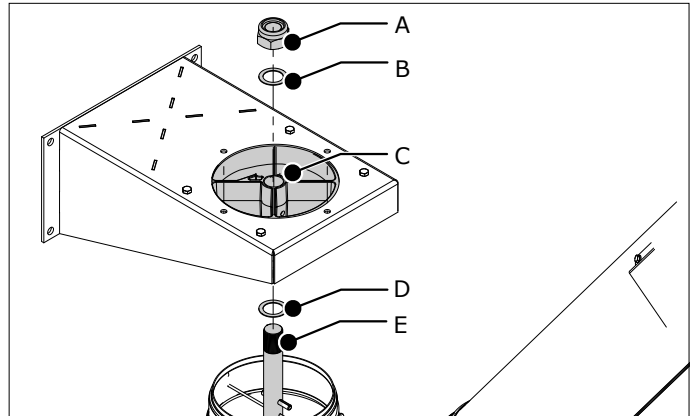

Fig. 4.4 Mounting of the hinge rod

**4.5.5 Swivel bracket**

Fig. 4.5

For transport reasons the bolt + nut are installed on position A.

- Change the bolt + nut from position A to B.

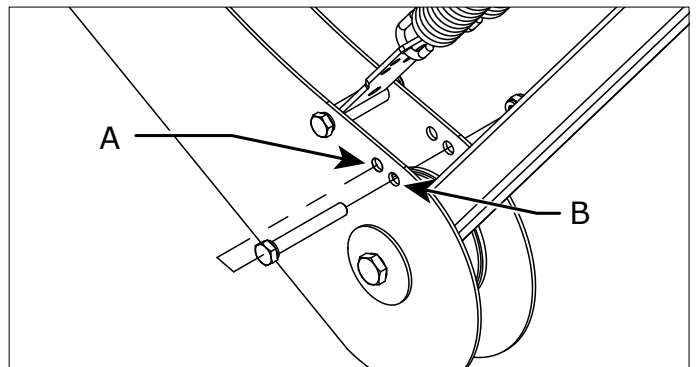

Fig. 4.5 Swivel bracket bolt + nut

#### 4.5.6 Hose

Fig. 4.6

- Slide the hose (C) over the aluminium collar (ref. Fig. 4.3D).
- Fasten the hose with the hose clamp (B).
- Slide the rubber collar (A) over the hose clamp to make the connection airtight.

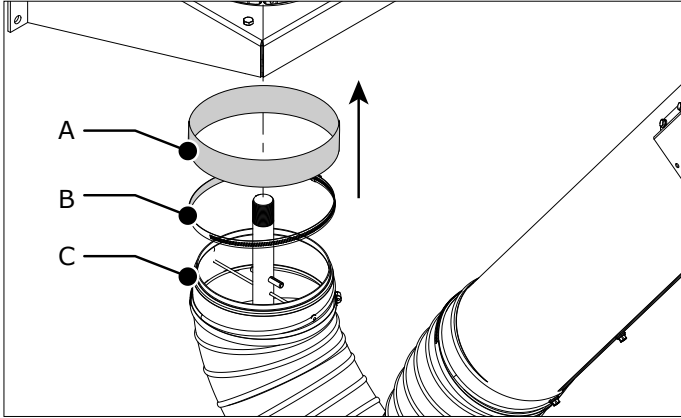

Fig. 4.6 Mounting of the hose

#### 4.5.7 Hood

Fig. 4.7

- Install the handle (F) of the hood to the bracket (E).
- Slide the hose (A) over the hood.
- Fasten the hose with the hose clamp (C).
- Slide the rubber collar (B) over the hose clamp to make the connection airtight.

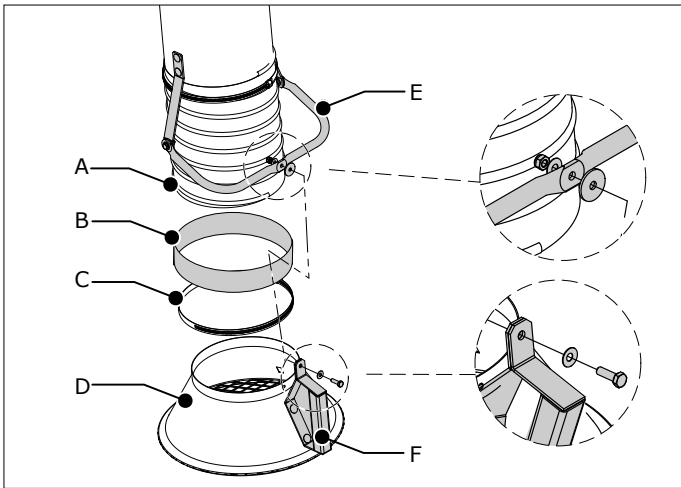

Fig. 4.7 Mounting of the hood

#### 4.5.8 Connection flange



In case you intend to install an extraction fan directly on the arm, you do not need the connection flange. In that case, proceed with paragraph 4.6.

Fig. 4.8

- Option<sup>8</sup>: cut the upper part of the flange to increase the diameter from  $\varnothing$  160 to 200 mm (A+B).
- Install the connection flange (C) on the wall bracket.

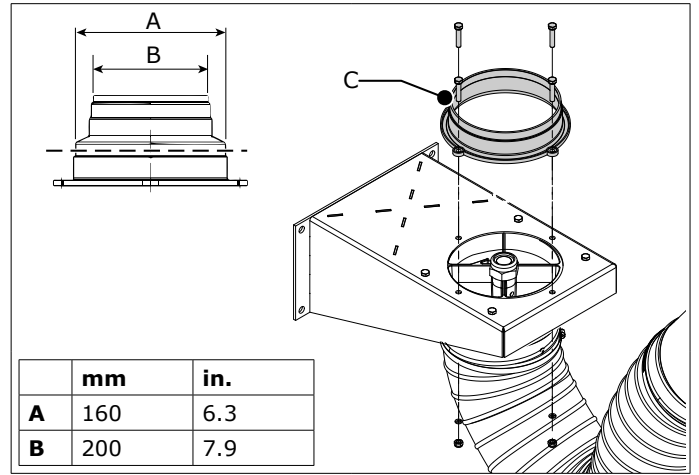

Fig. 4.8 Mounting of the connection flange

#### 4.6 Fan mounting

To install an extraction fan<sup>9</sup> directly on the arm, you must replace the connection flange of the fan by an arm-fan adapter.

Fig. 4.9

- Loosen the bolts and remove the connection flange (A) from the fan. Keep the bolts.
- Install the arm-fan adapter (B) to the fan with the bolts M8x16.

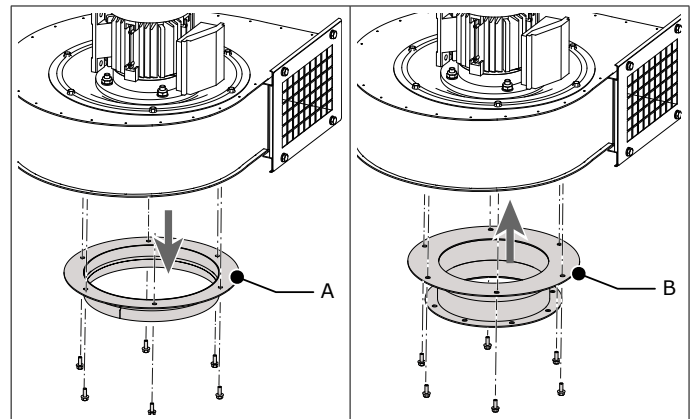

Fig. 4.9 Mounting of the arm-fan adapter

Fig. 4.10

- Install the arm-fan adapter + fan on the wall bracket with the bolts M8x40.

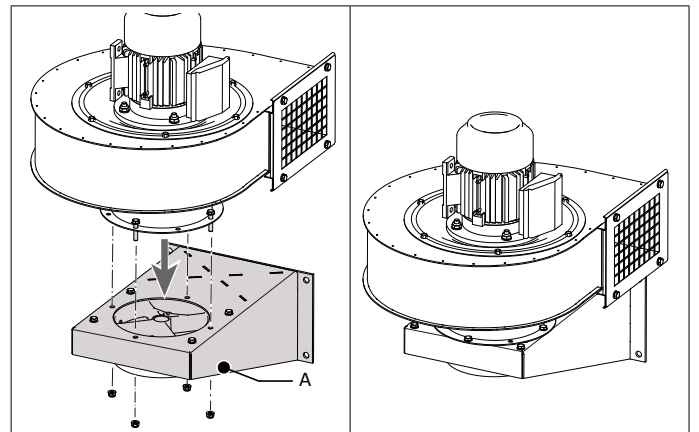

Fig. 4.10 Mounting of the fan

8. For connection to duct  $\varnothing$  200 mm

9. Suitable types: refer to paragraph 1.4

## 5 USE



### Personal protective equipment (PPE)

During use, use PPE to avoid injury. This also applies for persons who enter the work area.

### 5.1 Controls

The hood of the arm is provided with a handle for easy positioning and a valve to regulate or shut off the airflow. All movement of the arm is controlled from the hood.

Fig. 5.1

- A Shut-off & control valve
- B Handle

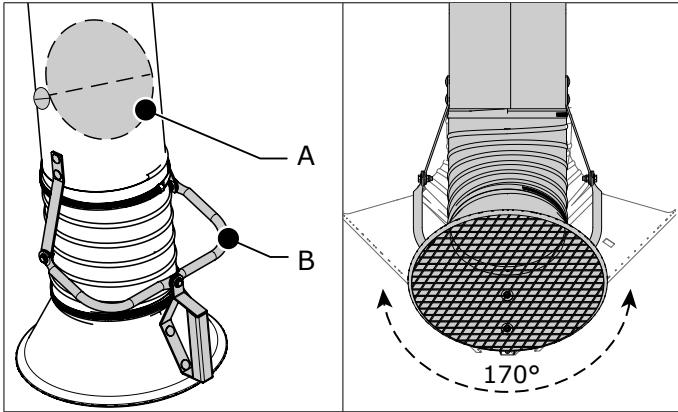
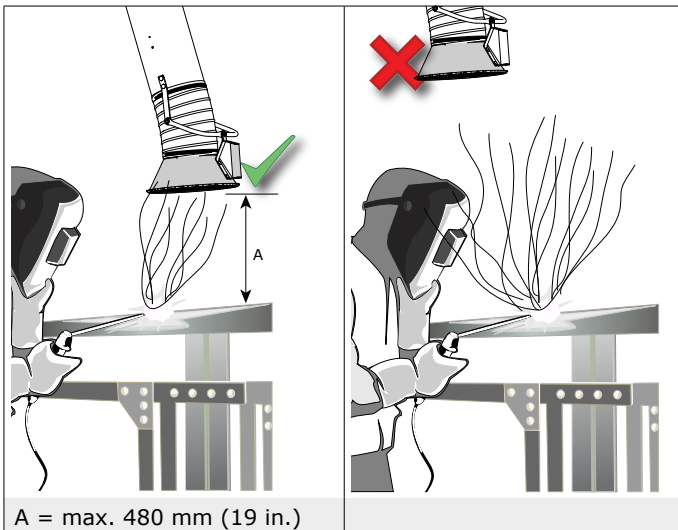

Fig. 5.1 Controls

### 5.2 Use

Fig. 5.2

- Use the handle (ref. Fig. 5.1B) to position the hood of the arm at max. 480 mm (19 in.) from the source of pollution.
- Make sure that the valve (ref. Fig. 5.1A) is open.
- Turn on the connected extraction fan or system.
- Start welding.
- If desired, partly close the valve to adjust the airflow.
- When the welding position changes, move the hood to the correct position in relation to the weld.
- Turn off the connected extraction fan or system approx. 20 seconds after finishing welding.



A = max. 480 mm (19 in.)

Fig. 5.2 Correct position of the hood

## 6 MAINTENANCE

### 6.1 Periodic maintenance



The product has been designed to function without problems for a long time with a minimum of maintenance. In order to guarantee this some simple, regular maintenance and cleaning activities are required which are described in this chapter. If you observe the necessary caution and carry out the maintenance at regular intervals, any problems occurring will be detected and corrected before they lead to a total breakdown.



#### WARNING!

Overdue maintenance can cause fire.

The indicated maintenance intervals can vary depending on the specific working and ambient conditions. Therefore we recommend to thoroughly inspect the complete product once every year beside the indicated periodic maintenance. For this purpose contact your supplier.

Component	Action	Frequency: every X months	
		X=3	X=6
Outside of the arm	Clean with a non-aggressive detergent	X	
Flexible hoses	Check for cracks or damages. Replace if necessary		X
Inside of the arm	Clean thoroughly		X
Hood	Check the movement of the hood. If necessary, adjust the friction; refer to paragraph 6.2		X
Arm movement	Check horizontal, vertical and diagonal arm movement. If necessary, adjust the friction; refer to paragraph 6.2		X
Rotating hinge	Lubricate the axle; refer to paragraph 6.3		X

### 6.2 Arm adjustment

If the extraction arm, or a part of it, does not stay in the desired position, you must adjust the friction.

Fig. 6.1

- Determine which joint needs more or less friction.
- Loosen the hose at that position to get access to the hinge.
- Pull the arm in a horizontal position.
- Adjust the friction; refer to the images below for the adjustment points.

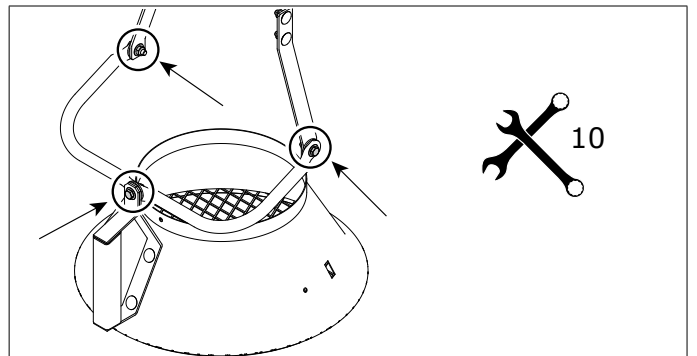

A Hood hinge



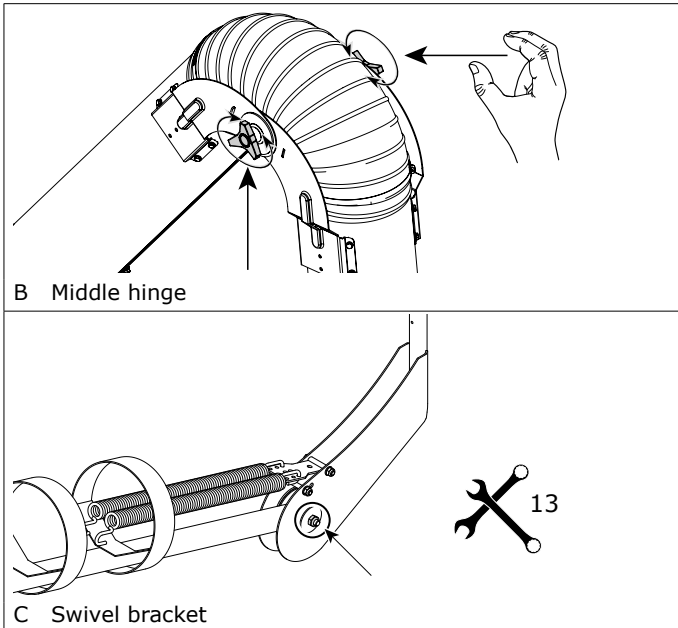

Fig. 6.1 Adjustment points

### 6.3 Lubrication

To make sure that the rotating hinge can turn freely, you must lubricate the axle regularly.

Fig. 6.2

- (A) Apply grease into the grease nipple with a grease gun.

Recommended grease type: standard EP2 bearing grease

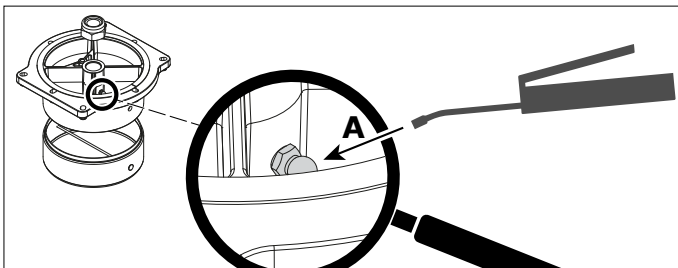

Fig. 6.2 Lubrication of the rotating hinge

## 7 TROUBLESHOOTING

If the product does not function (correctly), consult the checklist below to see if you can remedy the error yourself. Should this not be possible, contact your supplier.



### WARNING!

Obey the safety regulations that are written in chapter 3 when you carry out the activities below.

Symptom	Problem	Possible cause	Solution
The extraction arm does not stay in the desired position	Escape of fume; no proper extraction	Friction setting is not correct	Adjust the friction; refer to Fig. 6.1 for the adjustment points
You cannot get the arm in the desired position			

## 8 SPARE PARTS

The following spare parts are available for the product;  
- refer to exploded view Fig. III on page 11



## 9 DISPOSAL

After life of the product, dispose of it in accordance with federal, state or local regulations.



## CE DECLARATION

### CE declaration of conformity for machinery

We, Plymovent Manufacturing B.V., Koraalstraat 9, 1812 RK Alkmaar, Netherlands, herewith declare, on our own responsibility, that the products:



- KUA-200/3H ATEX
- KUA-200/4H ATEX

which this declaration refers to, have been manufactured in compliance with the directions of the Directive Council of 17th of May 2006 regarding machine safety 2006/42/EC, amended by the directive 95/16/EC with special reference to appendix I regarding basic health and safety requirements in connection with the construction and manufacturing of machinery.

Applicable standards:

- EN-ISO 12100:2010 | Safety of machinery  
Basic concepts, general principles for design
- EN-IEC 60079-11:2012  
Explosive atmospheres – Part 11: Equipment protection by intrinsic safety "i"
- ISO/IEC 80079-36  
Explosive atmospheres – Part 36: Non-electrical equipment for use in explosive atmospheres

The products are approved for zone 2 (Gas) and zone 22 (Dust), in accordance with the ATEX Directive 2014/34/EU.

Classification:

- Product group: II
- Product category: 3

Marking:

- Ex II 3G
- Ex II 3D

Signature:

Name: M.S.J. Ligthart  
Position: Product Manager  
Date of issue: 1st October 2020

Fig. I Working reach

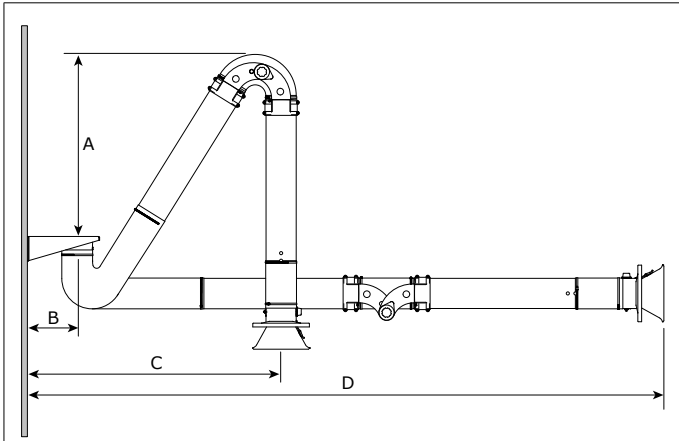

	<b>KUA-200/3H</b>		<b>KUA-200/4H</b>	
	mm	ft.	mm	ft.
<b>A</b>	1150	3¾	1450	4¾
<b>B</b>	345	1⅛	345	1⅛
<b>C</b>	min. 1450	min. 4¾	min. 1620	min. 5¾
<b>D</b>	max. 3440	max. 11¼	max. 4130	max. 13½

Fig. II Pressure drop

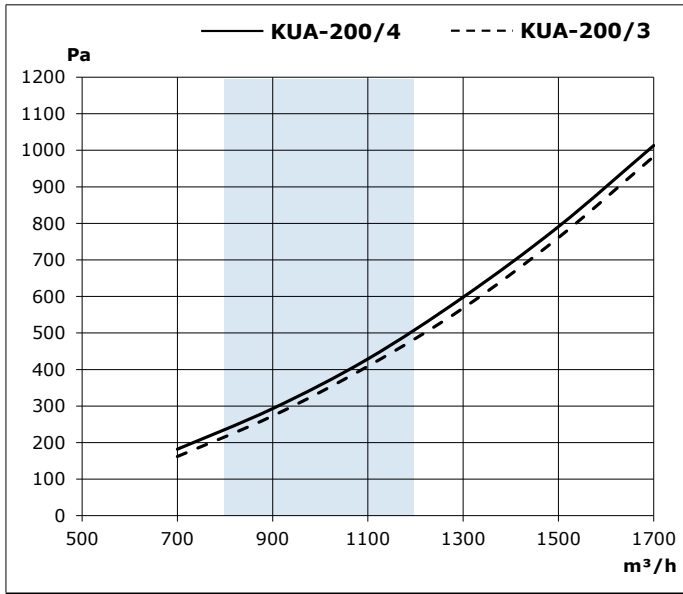
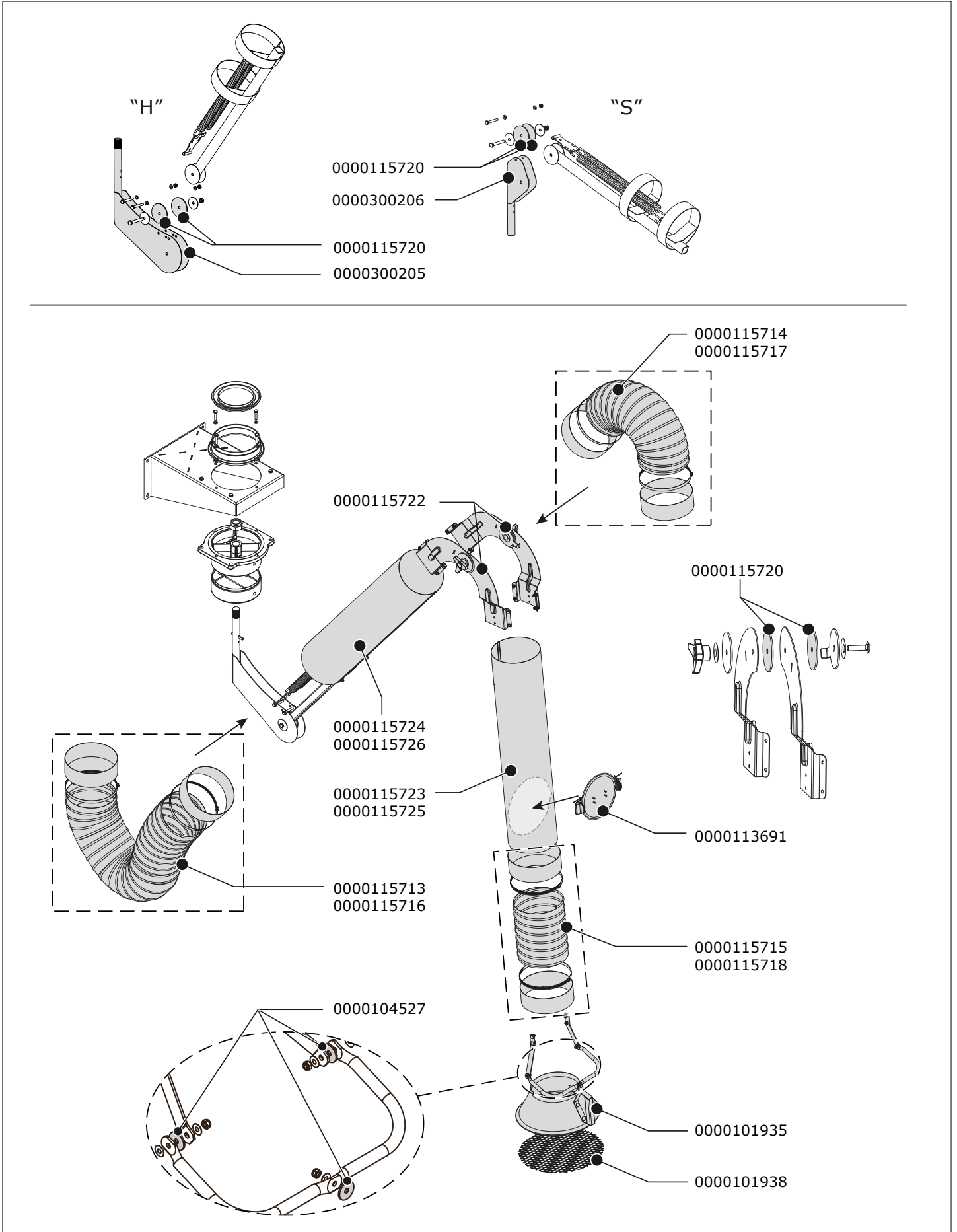

Fig. III Exploded view



Article no.	Description
<b>General</b>	
0000101935	Hood MSA-200 / KUA-200, incl. U-bracket
0000101938	Safety mesh Ø 340 mm
0000104527	Friction plate 25x6,5x2 mm (set of 3)
0000113691	Shut-off and control valve Ø 200 mm
0000115720	Friction plate 83x3 mm (set of 2)
0000115722	Elbow joint for KUA-200
0000300205	Swivel bracket for KUA-200/H
0000300206	Swivel bracket for KUA-200/S
<b>KUA-200/3H   KUA-200/3S</b>	
0000115713	Hose L=1000 mm/Ø 205 mm, incl. 2 hose clamps + 2 rubber collars
0000115714	Hose L=650 mm/Ø 205 mm, incl. 2 hose clamps + 2 rubber collars
0000115715	Hose L=450 mm/Ø 205 mm, incl. 2 hose clamps + 2 rubber collars
0000115723	Outer tube
0000115724	Inner tube
<b>KUA-200/4H   KUA-200/4S</b>	
0000115713	Hose L=1000 mm/Ø 205 mm, incl. 2 hose clamps + 2 rubber collars
0000115714	Hose L=650 mm/Ø 205 mm, incl. 2 hose clamps + 2 rubber collars
0000115715	Hose L=450 mm/Ø 205 mm, incl. 2 hose clamps + 2 rubber collars
0000115725	Outer tube
0000115726	Inner tube
<b>KUA-200/3H ATEX</b>	
0000115716	Antistatic hose L=1000 mm/Ø 205 mm, incl. 2 hose clamps + 2 rubber collars
0000115717	Antistatic hose L=650 mm/Ø 205 mm, incl. 2 hose clamps + 2 rubber collars
0000115718	Antistatic hose L=450 mm/Ø 205 mm, incl. 2 hose clamps + 2 rubber collars
0000115723	Outer tube
0000115724	Inner tube
<b>KUA-200/4H ATEX</b>	
0000115716	Antistatic hose L=1000 mm/Ø 205 mm, incl. 2 hose clamps + 2 rubber collars
0000115717	Antistatic hose L=650 mm/Ø 205 mm, incl. 2 hose clamps + 2 rubber collars
0000115718	Antistatic hose L=450 mm/Ø 205 mm, incl. 2 hose clamps + 2 rubber collars
0000115725	Outer tube
0000115726	Inner tube

