

## SIDE PANELS

### SIDE PANELS FOR DOWNDRAFT TABLE

Side panels improve the extraction effectiveness by reducing the influences of draught. They also prevent tools, metal and other parts to fall off the downdraft table. They are swivable to accommodate large workpieces.

The side panels consist of hinged trapezium-shaped sheet metal plates and have to be used in combination with the backdraft kit. They are to be mounted on the sides of the downdraft table.

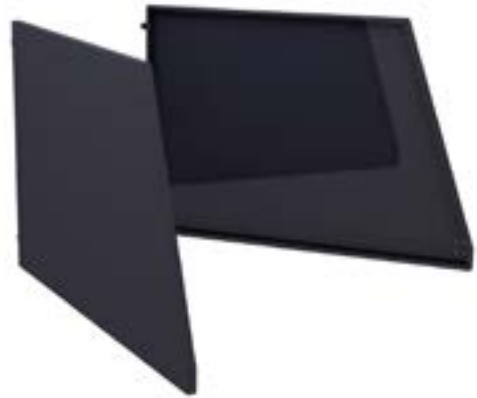

#### SPECIFICATIONS

■ Physical dimensions and properties	
Material	sheet metal
Colour	grey RAL 7011
Weight (net)	14,5 kg (32 lbs)
■ Product combinations	
DraftMax Basic	downdraft table with disposable filter (with backdraft kit)
DraftMax Ultra	downdraft table with automatic self-cleaning filter (with backdraft kit)
■ Scope of supply	
Left side panel - Right side panel	
■ Order information	
Article number	0040200030
Number/package	1 set
■ Shipping data	
Gross weight	15,5 kg (34 lbs)
Packing dimensions	960 x 640 x 55 mm (37¾ x 25¼ x 2⅛ in.)
Harmonized Tariff Code	8421.39.2090
Country of origin	Thailand

#### DIMENSIONS

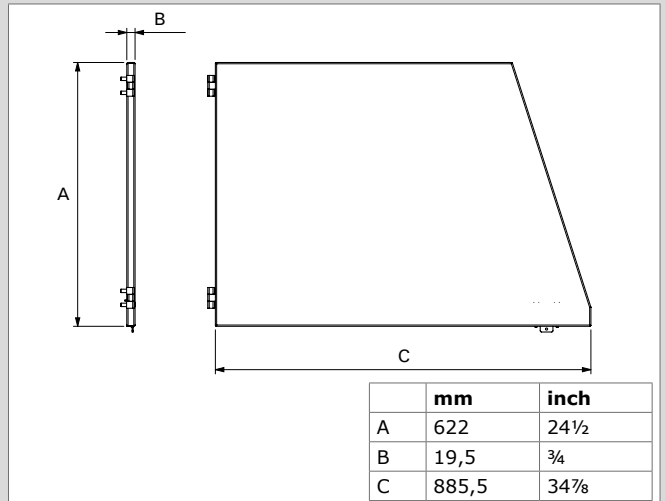

Side panel

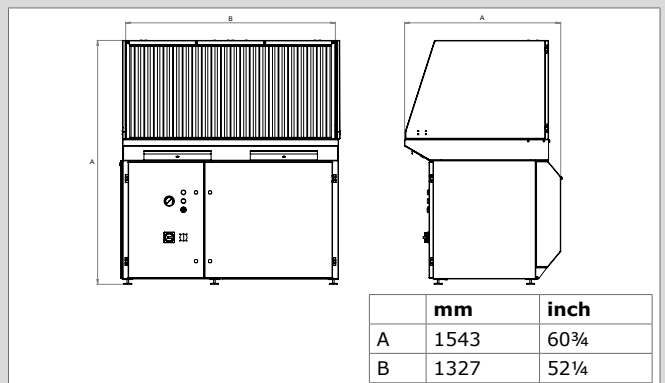

Downdraft table with backdraft kit and side panels (front view)

Product type  
Article no.  
Product category  
Version

**Side panels**  
0040200030  
options and accessories  
05MAR2024/F

Always check the latest version on [www.plymovent.com](http://www.plymovent.com)