

Mobile welding fume extractor

## MOBILEPRO | MOBILEPRO-W3

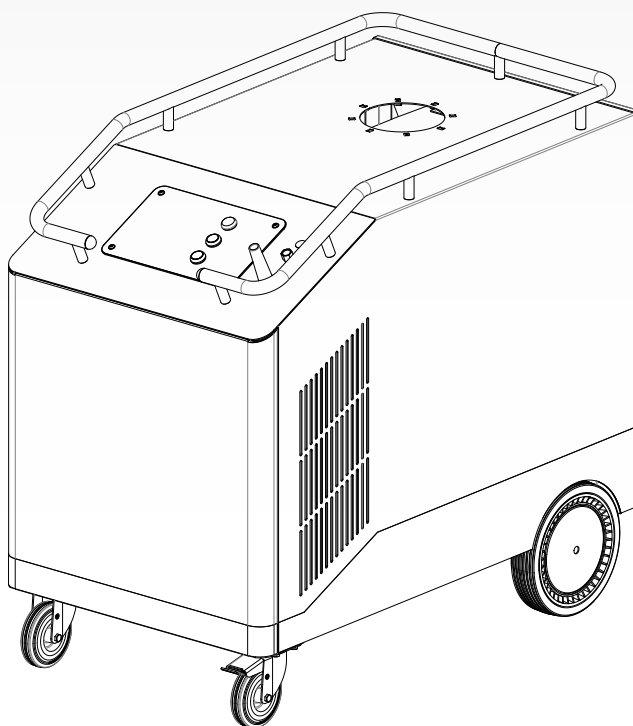

EN

Installation and user manual



---

---

## TABLE OF CONTENTS

PREFACE.....	2
1 INTRODUCTION.....	2
2 PRODUCT DESCRIPTION .....	3
3 SAFETY .....	4
4 INSTALLATION .....	5
5 USE .....	7
6 MAINTENANCE .....	8
7 TROUBLESHOOTING .....	9
8 SPARE PARTS .....	10
9 ELECTRICAL DIAGRAM .....	10
10 DISPOSAL.....	10
CE DECLARATION.....	10

### EN | ORIGINAL INSTRUCTION

All rights reserved. The information given in this document has been collected for the general convenience of our clients. It has been based on general data pertaining to construction material properties and working methods known to us at the time of issue of the document and is therefore subject at any time to change or amendment and the right to change or amend is hereby expressly reserved. The instructions in this publication only serve as a guideline for installation, use, maintenance and repair of the product mentioned on the cover page of this document. This publication is to be used for the standard model of the product of the type given on the cover page. Thus the manufacturer cannot be held responsible for any damage resulting from the application of this publication to the version actually delivered to you. This publication has been written with great care. However, the manufacturer cannot be held responsible, either for any errors occurring in this publication or for their consequences.

*To improve comprehension for people whose first language is not English, we have written parts of this manual in Simplified Technical English (STE). STE is a controlled language originally developed for aerospace industry maintenance manuals. It offers a carefully limited and standardized subset of English, along with specific writing rules.*

## PREFACE









### Using this manual

This manual is intended to be used as a work of reference for professional, well trained and authorised users to be able to safely install, use, maintain and repair the product mentioned on the cover of this document.

Due to a product enhancement, some images in this manual may differ from the actual product.

### Pictograms and symbols

The following pictograms and symbols are used in this manual:

	<b>TIP</b> Suggestions and recommendations to simplify carrying out tasks and actions.
	<b>ATTENTION</b> A remark with additional information for the user. A remark brings possible problems to the user's attention.
	<b>CAUTION!</b> Procedures, if not carried out with the necessary caution, could damage the product, the workshop or the environment.
	<b>WARNING!</b> Procedures which, if not carried out with the necessary caution, may damage the product or cause serious personal injury.
	<b>CAUTION!</b> Denotes risk of electric shock.
	<b>WARNING!</b> Fire hazard! Important warning to prevent fire.
	<b>WARNING!</b> Explosion hazard! Important warning to prevent explosions.
	<b>Personal protective equipment (PPE)</b> Instruction to use respiratory protection when you do service, maintenance and repair jobs, as well as during functional testing. We recommend to use a half-face respirator according to EN 149:2001 + A1:2009, class FFP3 (directive 89/686/EEC).
	<b>Personal protective equipment (PPE)</b> Instruction to use protective gloves when you do service, maintenance and repair jobs.

### Text indicators

Listings indicated by "-" (hyphen) concern enumerations. Listings indicated by "•" (bullet point) describe steps to perform.

### Service and technical support

For information about specific adjustments, maintenance or repair jobs which are not dealt with in this manual, please contact the supplier of the product. He will always be willing to help you. Make sure you have the following specifications at hand:

- product name
- serial number

You can find these data on the identification plate.

### Product indications

Unless specifically stated, the contents of this manual applies to the MobilePro as well as the MobilePro-W3.

## 1 INTRODUCTION

### 1.1 Identification of the product

The identification plate contains, among other things, the following data:

- product name
- serial number
- supply voltage and frequency
- power consumption



### 1.2 General description

The MobilePro is a mobile filter unit with integrated fan that provides extraction and filtration for use with an extraction arm. It features a cylindrical polyester filter cartridge. The unit is fitted with a RamAir™ pulse amplifier for cleaning of the filter cartridge by compressed air. Dust collection in the dust tray at the bottom of the unit. Thanks to the four transport wheels (two of which are swivel casters with brake), the MobilePro is suitable to be used in relatively small facilities or near sources of pollution without a fixed location. The versatile handlebar allows to place tools on the unit and prevents them from falling off.

### 1.3 Product combinations

To operate the unit, selection of one of the following products is required:

Ball-bearing extraction arm (360° rotatable):

- KUA-160/2S | 2 m (6½ ft)
- KUA-160/3S | 3 m (10 ft)
- KUA-160/4S | 4 m (13 ft)

Hose tube extraction arm (360° rotatable):

- EA-3/S | 3 m (10 ft)
- EA-4/S | 4 m (13 ft)

#### 1.3.1 Options and accessories

The following products can be obtained as an option and/or accessory:

- CART-OA | 100% BiCo polyester filter cartridge, anti-static (instead of CART-O)
- HEPA kit (H14 / 2 x 5,2 m<sup>2</sup> / 2 x 56 sq.ft)
- Activated carbon kit (2 x 6 kg / 2 x 13¼ lbs.)
- LL-5.5/24-160 | LED working light 5,5W with switch box (arm 359° rotatable)
- EFC | Detergent to wash the filter cartridge

### 1.4 Technical specifications

Physical dimensions and properties		
Material (housing)	electro-zinc coated steel	
Weight	169 kg (373 lbs.)	
Capacity of dust tray	10 litres (2½ gallon)	
Filter cartridge		
	MobilePro	MobilePro-W3
Type	CART-O	CART-O/PTFE/10
Filter material	100% BiCo polyester	100% BiCo polyester with PTFE membrane
Filter surface area	20 m <sup>2</sup> (215 ft <sup>2</sup> )	10 m <sup>2</sup> (108 ft <sup>2</sup> )
Dust class (according to DIN EN 60335-2-69)	M	M
Filter class (according to ASHRAE 52.2)	MERV 11	MERV 16
Washable (e.g. by using Plymovent EFC detergent)	yes	no

Compressed air system	
Required compressed air quality	dry and oil-free according to ISO 8573-3 class 6
Inlet pressure	5-10 bar (75-150 PSI)
Required pressure	5 bar (75 PSI) (by integrated pressure regulator)
Compressed air connection	G 3/8" (female)
Compressed air consumption	35 NI (1¼ ft <sup>3</sup> ) per pulse
Volume of compressed air tank	10 litres (2½ gallon)
Activation of filter cleaning system (online only)	- pressure controlled (threshold value: 1500 Pa) - manually by push button
Duration of filter cleaning cycle	60 seconds (6 pulses)

Fan	
Fan type	radial
Extraction capacity	max. 1200 m <sup>3</sup> /h (700 CFM) (incl. extraction arm)
Fan speed:	
- 50 Hz	- 2900 rpm
- 60 Hz	- 3390 rpm
Noise level	72 dB(A) according to ISO 3746

Electrical data	
Power consumption	1,1 kW (1.5 HP)
Available connection voltages	- 115V/1ph/50Hz - 115V/1ph/60Hz - 230V/1ph/50Hz - 400V/3ph/50Hz
Motor design	IEC
Energy efficiency:	
- single phase motor	- n.a.
- three-phase motor	- IE3 / premium
Mains cord:	
- type	- SJOOW 3xAWG14
- length	- 4,5 m (14¾ ft)
Plug:	Type:
- 115V/1ph/50Hz	- none
- 115V/1ph/60Hz	- NEMA 5-15P
- 230V/1ph/50Hz	- none
- 400V/3ph/50Hz	- none

 Refer to the available product data sheet for detailed product specifications.

## 1.5 Dimensions

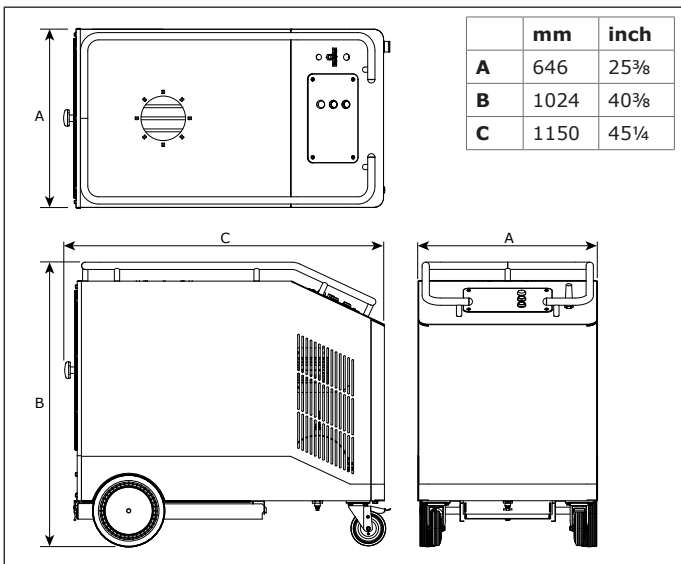

## 1.6 Working range

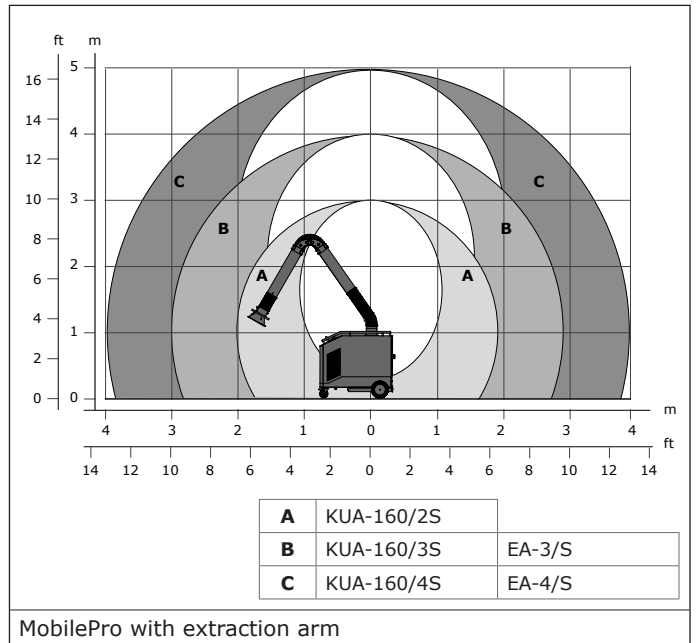

## 1.7 Ambient conditions

Process temperature:	
- min.	5°C (41°F)
- nom.	20°C (68°F)
- max.	70°C (158°F)
Max. relative humidity	90%
Suitable for outdoor use	no

## 1.8 Transport of the unit

You cannot hold the manufacturer liable for any transportation damage after delivery of the product. Handle the machine and the accompanying extraction arm with care. Completely dismantle the extraction arm before transport. Dismount the arm by executing the mounting procedure in reverse order. Subsequently the machine and the arm can be transported on a pallet in the original packing. To prevent damage, make sure that the machine and the arm cannot shift on the pallet.

# 2 PRODUCT DESCRIPTION

## 2.1 Components

The unit consists of the following main components and elements:

Fig. 2.1

- A Deflector plate
- B Filter cartridge
- C Dust tray
- D Handlebar
- E Control panel
- F Extraction fan
- G Outlet grid (2x)
- H RamAir™ pulse amplifier (filter cleaning system)

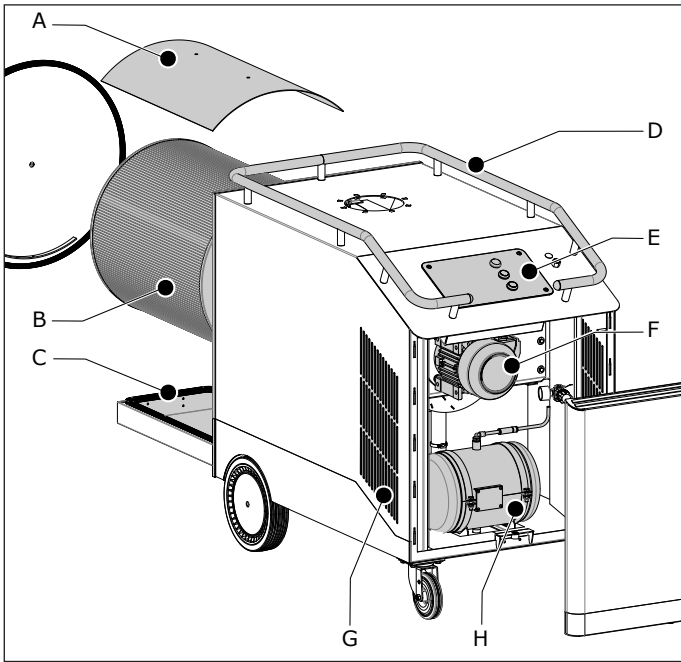

Fig. 2.1 Main components and elements

## 2.2 Operation

The MobilePro works in accordance with the recirculation principle. Welding fume is extracted through the hood of the connected extraction arm by the built-in fan. The polluted air passes the deflector plate<sup>1</sup> and is cleaned by the filter cartridge. The welding fume particles are collected at the outside of the filter cartridge. The cleaned air is returned in the workshop through the outlet grids on the sides of the unit.

### 2.2.1 Filter cleaning system

When the filter cartridge becomes saturated - and consequently the extraction capacity reduces -, a pressure switch activates the RamAir™ pulse amplifier, which thoroughly cleans the filter cartridge by compressed air pulses. This cleaning system can be activated manually as well. The dust and dirt particles fall into the dust tray.

The cleaning system only operates when the fan is running, to prevent dust particles to escape through the hood of the extraction arm.

The unit enters into the ALARM stage<sup>2</sup> when the differential pressure over the filter cartridge exceeds its threshold value of 1500 Pa.

## 3 SAFETY

### General

The manufacturer does not accept any liability for damage to the product or personal injury caused by ignoring of the safety instructions in this manual, or by negligence during installation, use, maintenance, and repair of the product mentioned on the cover of this document and any corresponding accessories.

Specific working conditions or used accessories may require additional safety instructions. Immediately contact your supplier if you detect a potential danger when using the product.



1. To protect the filter cartridge and to distribute the air equally inside the unit.
2. During the ALARM stage the fan continues to run.

**The user of the product is always fully responsible for observing the local safety instructions and regulations. Observe all applicable safety instructions and regulations.**

### User manual

- Everyone working on or with the product, must be familiar with the contents of this manual and must strictly observe the instructions therein. The management should instruct the personnel in accordance with the manual and observe all instructions and directions given.
- Do not change the order of the steps to perform.
- Keep the manual with the product.

### Users

- The use of this product is exclusively reserved to authorised, trained and qualified users. Temporary personnel and personnel in training can only use the product under supervision and responsibility of skilled engineers.
- Stay alert and keep your attention to your work. Do not use the product when you are under the influence of drugs, alcohol or medicine.
- The product is not to be used by children or persons with reduced physical, sensory or mental capabilities, or lack of experience and knowledge, unless they have been given supervision or instruction.
- Children must be supervised not to play with the product.

### Intended use<sup>3</sup>

The product has been designed exclusively for extracting and filtering gases and particles which are released during the most common welding processes. Using the product for other purposes is considered contrary to its intended use. The manufacturer accepts no liability for any damage or injury resulting from such use. The product has been built in accordance with state-of-the-art standards and recognised safety regulations. Only use this product when in technically perfect condition in accordance with its intended use and the instructions explained in the user manual.

### Technical specifications

Do not change the specifications given in this manual.

### Modifications

Modification of (parts of) the product is not allowed.

### Product combinations



If the product is used in combination with other products or machines, the safety instructions in the documentation of these products also apply.

### Installation

- The installation of this product is exclusively reserved to authorised, trained and qualified engineers.
- The electric connection must be executed in accordance with the local codes and requirements. Ensure compliance with the EMC regulatory arrangements.
- During installation, always use Personal Protective Equipment (PPE) to avoid injury. This also applies to persons who enter the work area during installation.
- Make sure that the workspace is well illuminated.
- Stay alert and keep your attention to your work. Do not install the product when you are under the influence of drugs, alcohol or medicine.

3. "Intended use" as explained in EN-ISO 12100-1 is the use for which the technical product is suited as specified by the manufacturer, inclusive of his directions in the sales brochure. In case of doubt it is the use which can be deduced from the construction, the model and the function of the technical product which is considered normal use. Operating the machine within the limits of its intended use also involves observing the instructions in the user manual.





## Use

	<b>WARNING!</b> Fire hazard! Do <b>not</b> use the product for: <ul style="list-style-type: none"><li>- polishing applications in combination with grinding, welding or any other application that generate sparks. (Fibers from polishing or abrasive flap disks are highly flammable and pose a high risk of filter fires when exposed to sparks.)</li><li>- arc-air gouging</li><li>- extracting and/or filtering flammable, glowing or burning particles or solids or liquids</li><li>- extracting and/or filtering of aggressive fumes (such as hydrochloric acid) or sharp particles</li><li>- extracting and/or filtering dust particles which are released when welding surfaces treated with primer</li><li>- sucking cigarettes, cigars, oiled tissues, and other burning particles, objects, and acids</li></ul>
	<b>WARNING!</b> Explosion hazard! Do <b>not</b> use the product for explosion-hazardous applications, e.g.: <ul style="list-style-type: none"><li>- aluminium laser cutting</li><li>- grinding aluminium and magnesium</li><li>- explosive environments or explosive substances/gases</li></ul>
	<b>WARNING!</b> Do <b>not</b> use the product for: <ul style="list-style-type: none"><li>- extraction of hot gases (more than 70°C/158°F continuously)</li><li>- flame spraying</li><li>- oil mist</li><li>- heavy oil mist in welding fume</li><li>- extraction of cement, saw dust, wood dust etc.</li></ul>

- Inspect the product and check it for damage. Verify the functioning of the safety features.
- Do not put the product in front of entrances and exits which must be used for emergency services.
- During use, always use Personal Protective Equipment (PPE) to avoid injury. This also applies for persons who enter the work area.
- Check the working environment. Do not allow unauthorised persons to enter the working environment.
- Protect the product against water and humidity.
- Make sure the room is always sufficiently ventilated; this applies especially to confined spaces.
- Make sure that the workshop, in the vicinity of the product, contains sufficient approved fire extinguishers (suitable for fire classes ABC).
- The welding current return circuit between the workpiece and the welding machine has a low resistance. Thus avoid connection between the workpiece and the MobilePro, so that there is no possibility of the welding current flowing back to the welding machine via the protective earth conductor of the MobilePro.

## Service, maintenance and repairs

- Obey the maintenance intervals given in this manual. Overdue maintenance can lead to high costs for repair and revisions and can render the guarantee null and void.
- Always use Personal Protective Equipment (PPE) to avoid injury. This also applies for persons who enter the work area.
- Make sure the room is sufficiently ventilated.
- Use tools, materials, lubricants and service techniques which have been approved by the manufacturer. Never use worn tools and do not leave any tools in or on the product.
- Clean the area afterwards.

	<b>ATTENTION</b> Service, maintenance and repairs must be performed in accordance with directive TRGS 560 and TRGS 528 by authorised, qualified and trained persons (skilled) using appropriate work practices.
	<b>ATTENTION</b> Before you carry out service, maintenance and/or repair jobs: <ul style="list-style-type: none"><li>- fully disconnect the unit from the mains</li><li>- disconnect the compressed air supply</li></ul>
	 <b>Personal protective equipment (PPE)</b> Wear respiratory protection and protective gloves during service, maintenance and repairs.
	<b>WARNING</b> The industrial vacuum cleaner that you use during service and maintenance must meet dust class H according to EN 60335-2-69 or HEPA class (efficiency $\geq 99.97\%$ at $0.3 \mu\text{m}$ ).

## 4 INSTALLATION

### 4.1 Tools and requirements

You need the following tools and requirements to install the unit:

- basic tools



#### 4.1.1 To be sourced locally

**For connection to the local mains** (50 Hz types only):

- a suitable plug



**For connection of the compressed air hose:**

- compressed air fitting G 3/8" (male)

**In case of working light LL-5.5/24-160 (option):**

- adhesive cable tie mounts and cable ties or equivalent

### 4.2 Unpacking

Make sure that the product is complete. The package contains:

- mobile filter unit
- hexagon bolt M6x25 (8) + washer (8) for connection of the extraction arm
- cable gland (2) for connection of the optional working light LL-5.5/24-160



Refer to Fig. I on page 11 for instructions to take the unit from the pallet.



#### **ATTENTION!**

Do **not** use a fork-lift truck to lift the unit. It will damage the dust tray.

### 4.3 Extraction arm

To operate the MobilePro you must install one of the following extraction arms:

- KUA-160/2S / KUA-160/3S / KUA-160/4S (ball bearing extraction arm)
- EA-3/S / EA-4/S (hose tube extraction arm)

To install the extraction arm, proceed as follows.

Fig. 4.1

- Install the rotating flange (H) on the filter housing with the 8 bolts M6x25 + washers.
- Move the hose clamp (D) and the rubber collar (E) over the hinge rod (B).
- Put the swivel ring (F) over the hinge rod (B)<sup>4</sup>.
- Put the washer (G) over the hinge rod.

**ATTENTION!**  
 Make sure to install the washer between the rotating flange and the swivel ring to avoid damage.

- Put the hinge rod (B) in the rotating flange (H) and attach it with the locking pin (C). Tighten it with a hex key.
- Put the hose (A) over the swivel ring (F).
- Tighten the hose with the hose clamp (D).
- Put the rubber collar (E) over the connection between the swivel ring (F) and the rotating flange (H) to make it airtight.

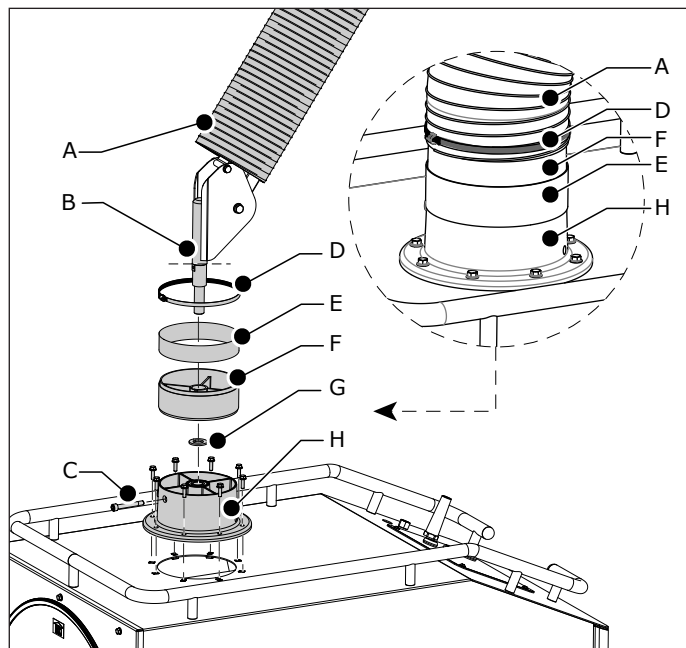



Fig. 4.1 Mounting of the extraction arm

 To assemble and adjust the extraction arm itself, refer to the corresponding manual.

#### 4.3.1 Option: working light LL-5.5/24-160

Fig. 4.2

- Install the working light in the hood of the extraction arm in accordance with the instruction sheet.
- Attach the cable (A) to the tubes of the arm and to the unit, e.g. with adhesive cable tie mounts and cable ties.

 Make sure that the cable is long enough:  
 - when the extraction arm is in fully folded position;  
 and  
 - to rotate the extraction arm (max. 359°)

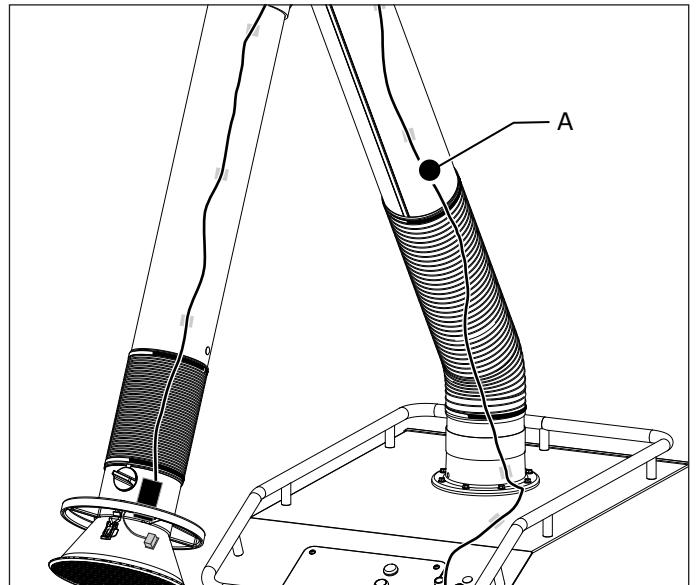

Fig. 4.2 Mounting of the working light cable

Fig. 4.3

- Loosen the bolt M10 (A) at the bottom the unit. Continue to turn the bolt until it gets fully loose<sup>5</sup>.

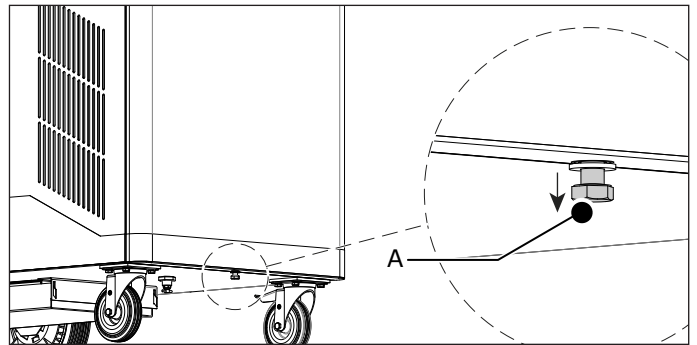

Fig. 4.3 Bolt to unlock the front panel

Fig. 4.4

- Push the front cover (A) down and remove it.

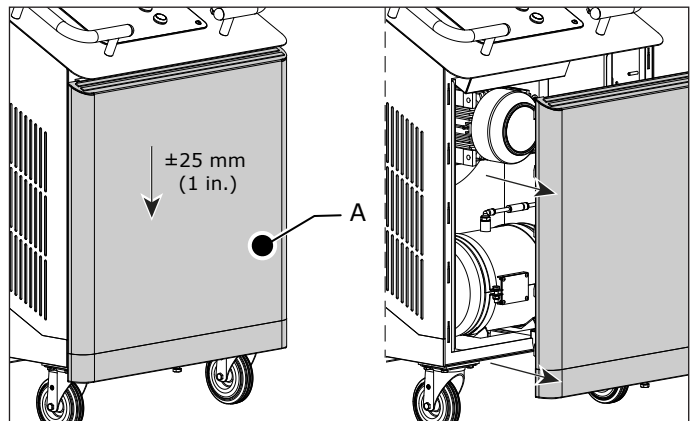

Fig. 4.4 Disassembly of the front cover

Fig. 4.5

- Remove the cover of the control panel (ref. Fig. 4.6B).
- Remove the cover caps at position B and C.
- Put a cable gland in both holes.
- Put the cable (A) through the cable glands.
- Tighten the cable glands.

4. The dashed line indicates the end position

5. The nut is locked to the front panel, so you cannot entirely remove it



- Connect the cable to the terminal block inside the control panel in accordance with the separately supplied electrical diagram.
- Install the front cover of the unit (instructions of Fig. 4.3 and Fig. 4.4 in reverse order).
- Install the cover of the control panel.

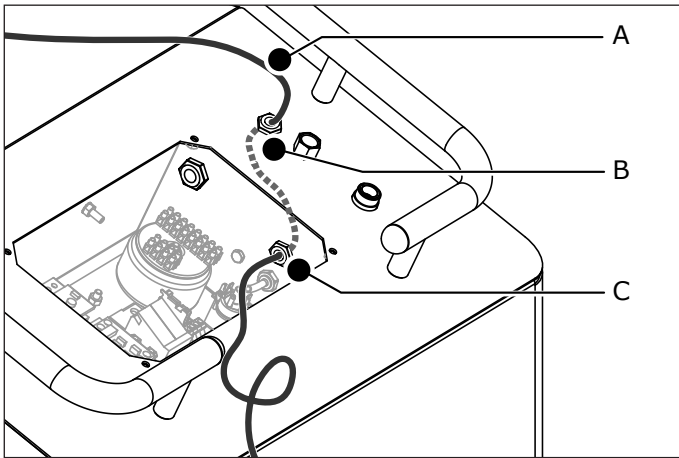

Fig. 4.5 Connection of the working light cable

#### 4.4 Compressed air connection



##### ATTENTION

The compressed air must be dry and oil-free according to ISO 8573-3 class 6.



##### ATTENTION

To maintain the protective layer of precoat material on the new filter cartridge, connect the compressed air only **after the first 30 running hours** of the MobilePro.

Fig. 4.6

- Put a compressed air fitting in the connector (A).
- Connect the unit to the compressed air supply.

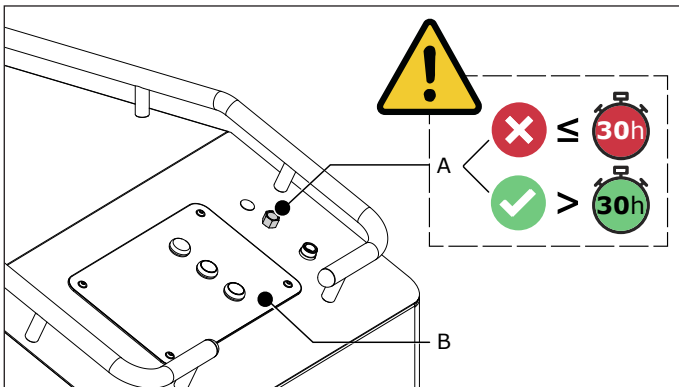

Fig. 4.6 Compressed air connection

#### 4.5 Electric connection



- Make sure that the unit is suitable for connection to the local mains.

You can find information about the connection voltage and frequency on the identification plate.

- Put the plug in the socket.

## 5 USE



### WARNING!

**Fire hazard!** Do **not** use the product for polishing applications in combination with grinding, welding or any other application that generate sparks.  
**Refer to chapter 3 / Use.**

### 5.1 Control panel

The control panel contains the following controls and indicator lights:

Fig. 5.1

- A ALARM | red light to indicate that the pressure drop exceeds the threshold value<sup>6</sup>
- B MANUAL CLEANING | black push button<sup>7</sup> to activate the filter cleaning system manually
- C START / STOP | push button with green LED to start and stop the fan

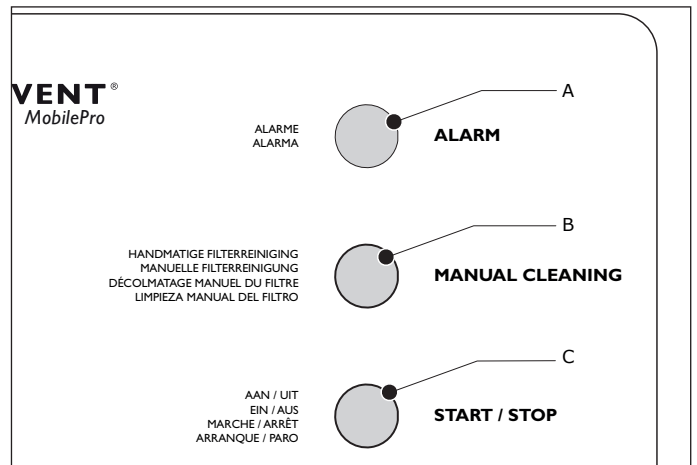

Fig. 5.1 Control panel

### 5.2 Use

Since it concerns a mobile unit, you can use it at any desirable place. For optimal results you must place the unit as close as possible to the source of pollution.

- If possible:  
Connect the unit to the external compressed air supply. Refer to section 5.3 ("preferred way").
- Position the hood of the connected extraction arm at max. 480 mm (19 in.) from the source of pollution. Refer to Fig. II on page 11 for the correct position.
- Push the START/STOP button (ref. Fig. 5.1C) to start the fan.
- Start welding.
- When the welding position changes, move the hood to the correct position in relation to the weld.



### WARNING

To keep the welding fume away from the breathing zone of the welder, make sure that all fume is extracted through the hood.

- Push the START/STOP button approx. 20 seconds after you have finished welding to stop the fan.

During use, do a regular check on the status of the ALARM indicator light (ref. Fig. 5.1A). When the ALARM light is on, it means that the pressure drop exceeds the threshold value. This can have two causes:

6. Delay time: 10 minutes
7. To activate: push and hold 5 seconds

## No filter cleaning due to absence of compressed air

- Proceed with section 5.3.1.

## Clogged filter cartridge

- Proceed with section 6.3.



To suppress the ALARM light temporarily: push the START/STOP button two times (off and on). The ALARM light comes on again after 10 minutes, unless you have solved the problem.



**WARNING**  
If you do not take the necessary action to solve the problem, the airflow (extraction capacity) further drops.

## 5.3 Filter cleaning system

One cleaning cycle takes approx. 60 seconds and consists of six compressed air pulses.

### Preferred way

We recommend to keep the compressed air supply connected during use. In this situation, a pressure switch activates the filter cleaning system immediately when the pressure drop reaches the threshold value. This guarantees the optimum performance of the unit and prevents the unit to go into ALARM.

### Alternative

If it is not possible to have compressed air available during every use, you must activate the filter cleaning system manually.

### Two possible procedures:

1. Activate MANUAL CLEANING on a regular basis<sup>8</sup> before the unit goes into ALARM. This extends the lifespan of the filter cartridge and optimizes the performance of the unit.
2. Activate MANUAL CLEANING as soon as the unit goes into ALARM<sup>9</sup>.

### 5.3.1 Manual filter cleaning

To activate the filter cleaning system manually, proceed as follows.

- Connect the unit to the compressed air supply.
- Make sure that the fan is running: the green LED (ref. Fig. 5.1C) is on.
- Push and hold the MANUAL CLEANING button (ref. Fig. 5.1B) for 5 seconds to activate the cleaning system.
- Push the START/STOP button (ref. Fig. 5.1C) two times (off and on) to reset the ALARM light.

## 6 MAINTENANCE

### 6.1 Periodic maintenance



The product has been designed to function without problems for a long time with a minimum of maintenance. In order to guarantee this some simple, regular maintenance and cleaning activities are required which are described in this chapter. If you observe the necessary caution and carry out the maintenance at regular intervals, any problems occurring will be detected and corrected before they lead to a total breakdown.



**WARNING!**  
Overdue maintenance can cause fire.

8. The optimum frequency to activate the cleaning system manually depends on the intensity of use and will be a matter of experience.

9. During the ALARM stage the fan continues to run.

The indicated maintenance intervals can vary depending on the specific working and ambient conditions. Therefore it is recommended to thoroughly inspect the complete product once every year beside the indicated periodic maintenance. For this purpose contact your supplier.



Component	Action	Frequency: every X months			
		X=1-3	X=3	X=6	X=12
Dust tray	Empty; refer to section 6.2.	X *)			
Housing	Clean the outside with a non-aggressive detergent.			X	
	Clean the inside with an industrial vacuum cleaner and remove dust from the filter compartment.		X		
	Check sealing material. Replace if necessary.				X
Filter cartridge	Check for damage, clogging and saturation. Replace if necessary.		X		
Extraction fan	Check for encrusted particles. Clean if necessary.				X
Pressure regulator	Make sure that the pressure setting is correct (5 bar).				X
Mains cord	Check for damage. Repair or replace if necessary.	X **)			

\*) During use, you must check the level of contents in the dust tray regularly. The emptying frequency depends on the intensity of use and will be a matter of experience. In the initial stage, do a check on the level of contents of the dust tray 2 times per month.

\*\*\*) Before every use

### 6.2 Emptying the dust tray

Location of the dust tray: in the dust tray holder at the bottom of the unit. The dust tray holder is locked by a draw latch (ref. Fig. 6.1A).

**Personal protective equipment (PPE)**  
Wear respiratory protection and protective gloves when you empty the dust tray.



**ATTENTION**  
The industrial vacuum cleaner that you use to empty the dust tray must meet dust class H according to EN 60335-2-69 or HEPA class (efficiency  $\geq 99.97\%$  at  $0.3 \mu\text{m}$ ).



**WARNING**  
- Prevent excessive draughts.  
- Do **not** empty or open the dust tray while the fan is running.

To empty the dust tray, proceed as follows.

Fig. 6.1

- Option: push and hold the MANUAL CLEANING button (ref. Fig. 5.1B and section 5.3.1) for 5 seconds to activate an additional cleaning cycle. This takes approx. 60 seconds.
- Make sure that the compressed air is disconnected.
- De-energize the unit.
- Unlock the dust tray. The dust tray holder (B) comes down.

- Gradually take out the dust tray (C) and empty it with an industrial vacuum cleaner at the same time.
- Put the dust tray back in the holder and lock it.

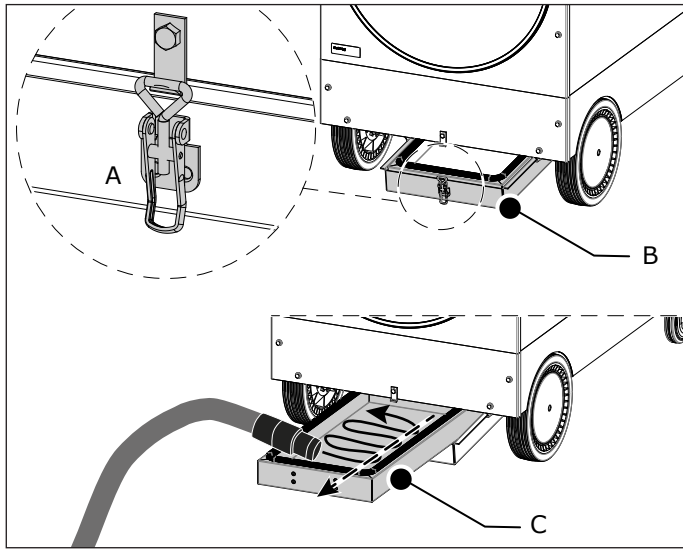
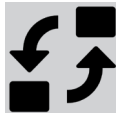

Fig. 6.1 Emptying the dust tray

### 6.3 Filter replacement



**Personal protective equipment (PPE)**  
Wear respiratory protection and protective gloves when you replace the filter cartridge.



**WARNING**  
Do **not** replace the filter cartridge while the fan is running.

To replace the filter cartridge, proceed as follows.

- Option: push and hold the MANUAL CLEANING button (ref. Fig. 5.1B and section 5.3.1) for 5 seconds to activate an additional cleaning cycle. This takes approx. 60 seconds.
- Make sure that the compressed air supply is disconnected.
- De-energize the unit.
- Loosen the star knob (F) and disassemble the cover plate (E), the nut (D) and the metal washer (C).
- Remove the filter cartridge (B) and put it in the plastic sack in which the replacement filter cartridge is supplied.
- Seal the sack securely.
- Clean the filter housing with an industrial vacuum cleaner.
- Put a new filter cartridge on the cartridge holder (A) and attach it with the disassembled parts. Make sure that you tighten the nut (D) correctly and that you mount the cover plate (E) in the right position<sup>10</sup>.
- Dispose of the used filter cartridge in accordance with federal, state or local regulations.
- Clean the environment of the unit.



**ATTENTION**  
To maintain the protective layer of precoat material on the new filter cartridge, connect the compressed air only **after 30 running hours** of the MobilePro after filter replacement (also refer to Fig. 4.6 on page 7).

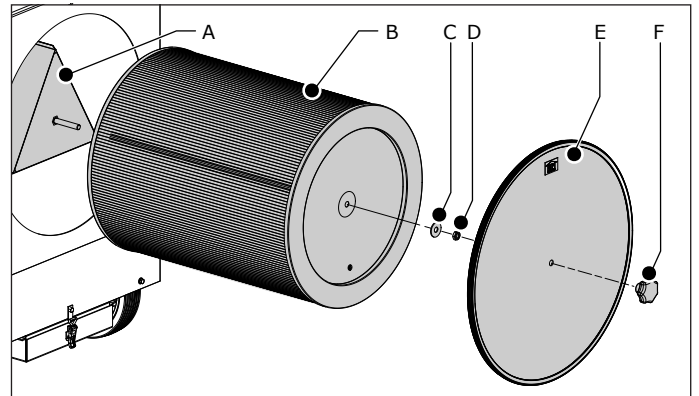

Fig. 6.2 Filter replacement

#### 6.3.1 Filter washing

To extend the lifespan of the filter cartridge, you can wash it a number of times before you finally have to replace it<sup>11</sup>.



**Personal protective equipment (PPE)**  
Wear respiratory protection and protective gloves when you wash the filter cartridge.



**ATTENTION**  
- Handle the filter cartridge with care.  
- Make sure that the filter cartridge is not damaged.

To wash the filter cartridge, proceed as follows.

- Disassemble the filter cartridge as described in section 6.3.
- Soak it in water with EFC detergent at max. 60°C (140°F).
- Hose it clean.
- Let it dry thoroughly.



**ATTENTION**  
No steam cleaning.

## 7 TROUBLESHOOTING

If the unit does not function (correctly), consult the checklist below to see if you can remedy the error yourself. Should this not be possible, contact your supplier.



**WARNING**  
Obey the safety regulations that are written in chapter 3 when you carry out the activities below.

Symptom	Problem	Possible cause	Solution
ALARM light is on	No filter cleaning	No compressed air available or air pressure too low	Connect or repair the compressed air supply. Subsequently: - push the MANUAL CLEANING button (hold for 5 seconds) - push the START/STOP button two times to reset the ALARM light
		Clogged filter cartridge	Replace the filter cartridge

11. You must replace the filter cartridge immediately when it is damaged or when the ALARM light remains on during use, which indicates that the filter cartridge is clogged.

10. Sticker "UP" indicates the top of the cover plate.

Symptom	Problem	Possible cause	Solution
The ALARM light remains on after manual filter cleaning	-	No reset	Push the START/STOP button 2 times (off and on)
	Extraction capacity insufficient	Clogged filter cartridge	Replace the filter cartridge
The fan does not start	The unit does not function	No mains voltage	Connect the mains voltage
		The mains cord is defective	Repair or replace the mains cord
		Loose contacts	Repair the contacts
		Motor defective	Repair or replace the motor
		START/STOP button (green) is defective	Replace the green button
		Thermal relay is activated	Reset the thermal relay
The fan makes a humming sound, but does not run	Extraction capacity insufficient or no extraction at all	Motor uses 2 phases instead of 3 (3-phase motor only)	Repair the phase connection
		Thermal relay is defective	Replace the thermal relay
Poor extraction capacity	The unit does not function properly	Inverted direction of rotation of the motor (3-phase motor only)	Change the direction of rotation
		Clogged filter cartridge	Replace the filter cartridge
	Pollution of the facility	Filter cartridge ripped or placed incorrectly	Replace the filter cartridge or place it correctly
		No filter cleaning	Loose compressed air connection
Hissing sound	No filter cleaning	No compressed air available or air pressure too low	Connect or repair the compressed air supply
		Magnetic valve defective or worn	Replace the magnetic valve
		Magnetic valve defective or worn	Replace the magnetic valve
MANUAL CLEANING button does not react	No manual activation of the filter cleaning system	The button is not held long enough.	Push and hold the button for 5 seconds.
		MANUAL CLEANING button (black) is defective.	Replace the black button.

## 8 SPARE PARTS

For the available spare parts, refer to the exploded view (Fig. III on page 12) and spare parts list (Fig. IV on page 13).



## 9 ELECTRICAL DIAGRAM

Refer to the separately supplied electrical diagram.

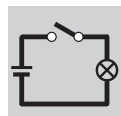

## 10 DISPOSAL

Dismantling and disposal of the unit must be done by qualified persons.



**Personal protective equipment (PPE)**  
Wear respiratory protection and protective gloves when you dismantle and dispose of the unit.

### 10.1 Dismantling

To safely dismantle the unit, obey the safety instructions that follow.

Before dismantling of the unit:

- disconnect it from the mains
- disconnect it from the compressed air
- clean the outside

During dismantling of the unit:

- make sure that the area is sufficiently ventilated, e.g. by a mobile ventilation unit

After dismantling of the unit:

- clean the dismantling area

### 10.2 Disposal

Dispose of the pollutants and dust, together with the used filter cartridge, in a professional manner in accordance with federal, state or local regulations.

## CE DECLARATION

### CE declaration of conformity for machinery



We, Plymovent Manufacturing B.V., Koraalstraat 9, 1812 RK Alkmaar, Netherlands, herewith declare, on our own responsibility, that the products:

- MobilePro
- MobilePro-W3

which this declaration refers to, are in accordance with the conditions of the following Directives:

- Machine Directive 2006/42 EC
- EMC 2014/30 EC
- LVD 2014/35 EC
- ErP Directive 2009/125 EC

Signature:

Name: M.S.J. Ligthart  
Position: Product Manager  
Date of issue: 15th December 2017

Fig. I Instructions to take the unit from the pallet

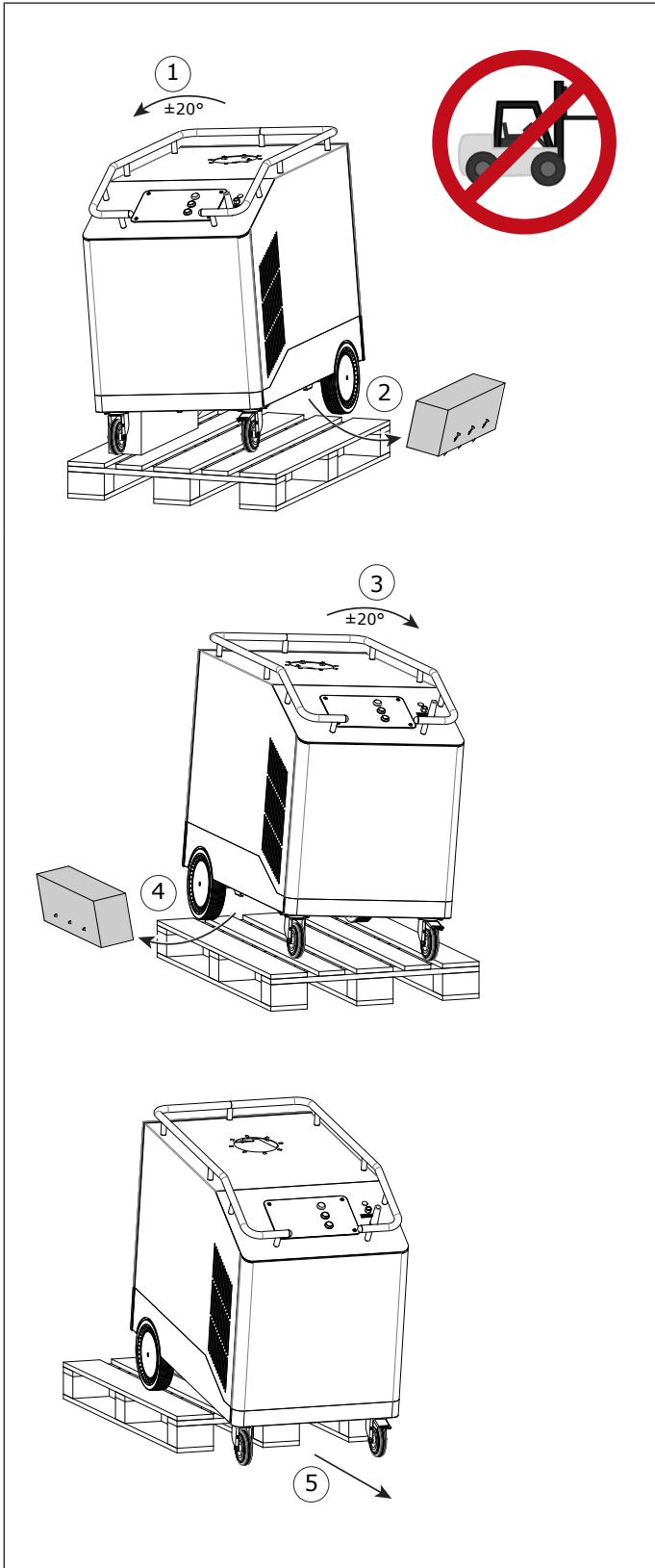

Fig. II Positioning of the extraction arm

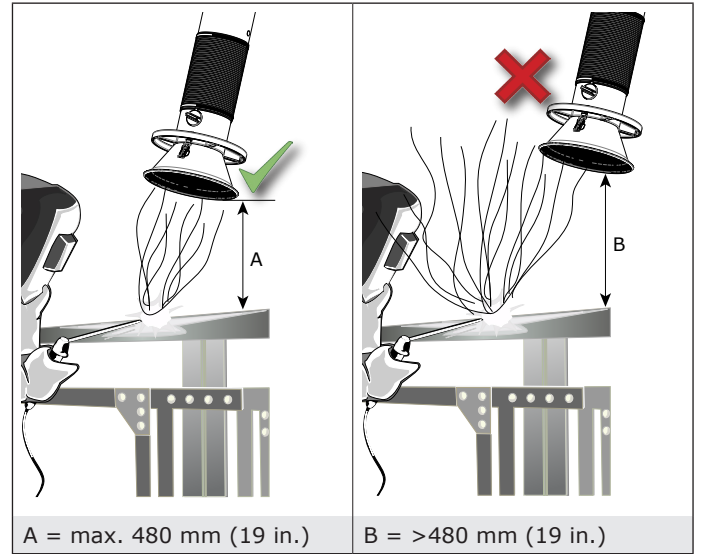

Fig. III Exploded view

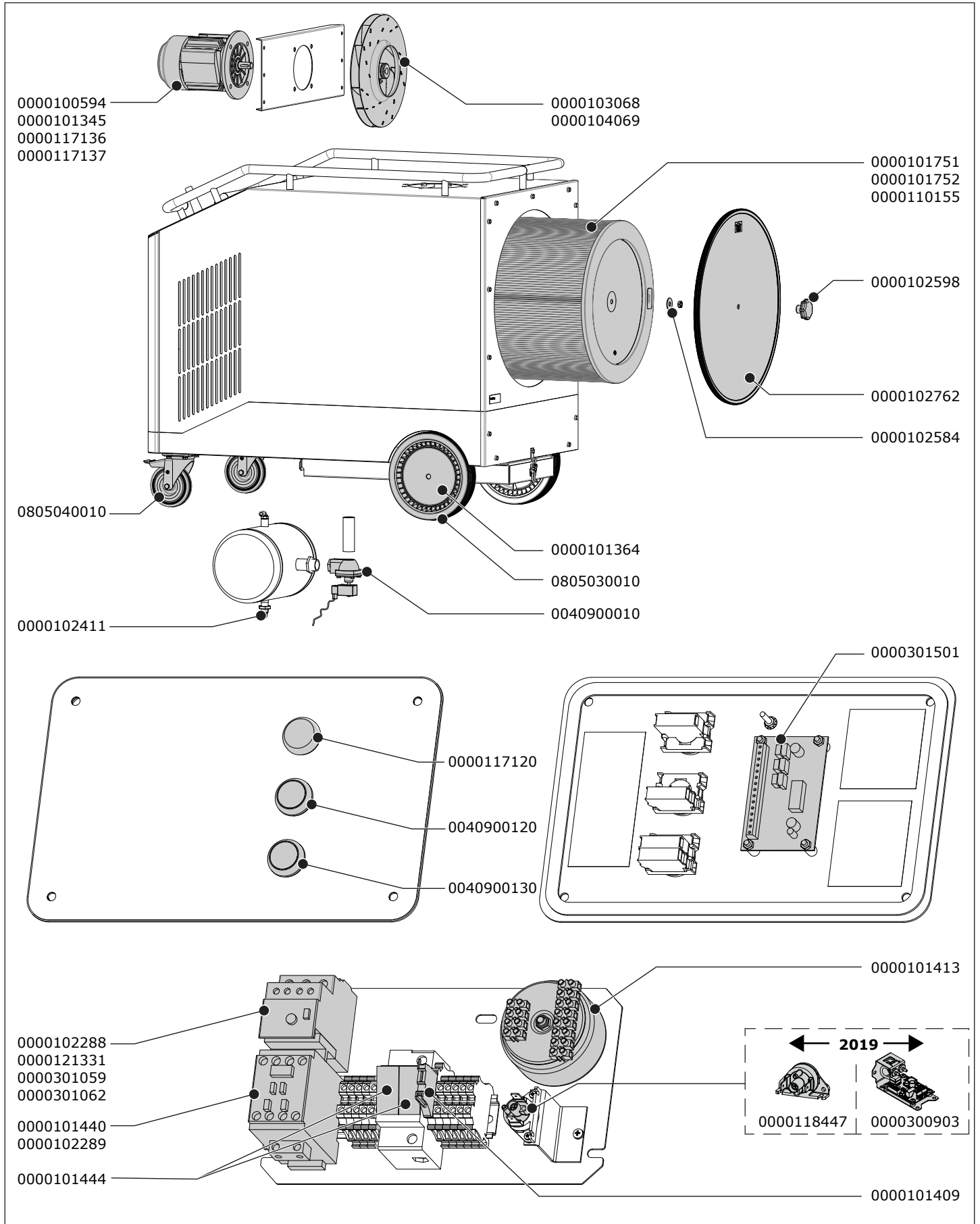

Fig. IV Spare parts

Article no.	Description
<b>General</b>	
0000101364	Wheel cover grey (2 pieces)
0000101409	Fuse 3.15A 5x20 mm UL
0000101413	Transformer 120-575V 24V 75VA
0000101444	Fuse class CC 0,5 A
0000102411	Drain valve ½ inch
0000102584	Lock kit for CART filter cartridge
0000102598	Star knob M12
0000102762	Cover plate for filter cartridge
0000117120	Service indicator (red LED)
0000117906	Coil 24V AC incl. connector
0000117908	Membrane (square) + spring for magnetic valve
0000118447	Pressure switch 1450 Pa
0000300903	Digital pressure switch 24 VAC
0000301501	PC board MobilePro, incl. software MP-v2.0
0040900010	Magnetic valve AC
0040900120	Push button black
0040900130	Push button green incl. LED
0805030010	Wheel Ø 250 mm black (excl. wheel cover)
0805040010	Swivel castor Ø 125 mm with brake
<b>MobilePro 230V/1ph/50Hz</b>	
0000101751	CART-O / Filter cartridge *
0000101752	CART-OA / Filter cartridge *
0000102289	Relay MC2A
0000104069	Fan wheel MobilePro (50Hz)
0000117136	Motor 1,1 kW; 230V/1ph/50Hz (IEC)
0000301062	NTR 5.7-7.6A / Thermal relay
<b>MobilePro 230V/1ph/60Hz</b>	
0000101751	CART-O / Filter cartridge *
0000101752	CART-OA / Filter cartridge *
0000103068	Fan wheel MobilePro (60Hz)
0000117137	Motor 1,1 kW; 115-230V/1ph/60Hz (IEC)
0000301062	NTR 5.7-7.6A / Thermal relay
<b>MobilePro 230V/3ph/60Hz</b>	
0000101345	Motor 1,1 kW; 208-220/460V/3ph/60Hz (IEC)
0000101751	CART-O / Filter cartridge *
0000101752	CART-OA / Filter cartridge *
0000102288	NTR 3.0-4.7A / Thermal relay
0000103068	Fan wheel MobilePro (60Hz)
<b>MobilePro 400V/3ph/50Hz+N</b>	
0000100594	Motor 1,1 kW; 230-400V/3ph/50Hz (IEC)
0000101751	CART-O / Filter cartridge *
0000101752	CART-OA / Filter cartridge *
0000102289	Relay MC2A
0000104069	Fan wheel MobilePro (50Hz)
0000301059	NTR 2.3-3.1A / Thermal relay
<b>MobilePro-W3 115V/1ph/50Hz</b>	
0000104069	Fan wheel MobilePro (50Hz)
0000110155	CART-O/PTFE/10 / Filter cartridge *
0000121331	NTR 13-18A / Thermal relay
<b>MobilePro-W3 115V/1ph/60Hz</b>	
0000101440	Relay 100-C23KJ10
0000103068	Fan wheel MobilePro (60Hz)
0000110155	CART-O/PTFE/10 / Filter cartridge *
0000117137	Motor 1,1 kW; 115-230V/1ph/60Hz (IEC)

Article no.	Description
0000121331	NTR 13-18A / Thermal relay
<b>MobilePro-W3 230V/1ph/50Hz</b>	
0000102289	Relay MC2A
0000104069	Fan wheel MobilePro (50Hz)
0000110155	CART-O/PTFE/10 / Filter cartridge *
0000117136	Motor 1,1 kW; 230V/1ph/50Hz (IEC)
0000301062	NTR 5.7-7.6A / Thermal relay
<b>MobilePro-W3 400V/3ph/50Hz+N</b>	
0000100594	Motor 1,1 kW; 230-400V/3ph/50Hz (IEC)
0000102289	Relay MC2A
0000104069	Fan wheel MobilePro (50Hz)
0000110155	CART-O/PTFE/10 / Filter cartridge *
0000301059	NTR 2.3-3.1A / Thermal relay

\* Filter cartridge, incl. face mask, disposable gloves and plastic sack with seal for collection and disposal of the used filter cartridge

