

Environmental diluter system

SCS-DILUTER PRO



EN

Installation and user manual

TABLE OF CONTENTS

PREFACE.....	2
1 INTRODUCTION.....	2
2 PRODUCT DESCRIPTION	3
3 SAFETY INSTRUCTIONS	5
4 INSTALLATION	6
5 COMMISSIONING	15
6 USE	16
7 MAINTENANCE	17
8 TROUBLESHOOTING	18
9 SPARE PARTS	19
10 ELECTRICAL DIAGRAM	19
11 DISPOSAL.....	19
CE DECLARATION.....	19

EN | ORIGINAL INSTRUCTION

All rights reserved. The information given in this document has been collected for the general convenience of our clients. It has been based on general data pertaining to construction material properties and working methods known to us at the time of issue of the document and is therefore subject at any time to change or amendment and the right to change or amend is hereby expressly reserved. The instructions in this publication only serve as a guideline for installation, use, maintenance and repair of the product mentioned on the cover page of this document. This publication is to be used for the standard model of the product of the type given on the cover page. Thus the manufacturer cannot be held responsible for any damage resulting from the application of this publication to the version actually delivered to you. This publication has been written with great care. However, the manufacturer cannot be held responsible, either for any errors occurring in this publication or for their consequences.

To improve comprehension for people whose first language is not English, we have written parts of this manual in Simplified Technical English (STE). STE is a controlled language originally developed for aerospace industry maintenance manuals. It offers a carefully limited and standardized subset of English, along with specific writing rules.









PREFACE

Using this manual

This manual is intended to be used as a work of reference for professional, well trained and authorised users to be able to safely install, use, maintain and repair the product mentioned on the cover of this document.

Pictograms and symbols

The following pictograms and symbols are used in this manual:

	TIP Suggestions and recommendations to simplify carrying out tasks and actions.
	ATTENTION A remark with additional information for the user. A remark brings possible problems to the user's attention.
	CAUTION Procedures, if not carried out with the necessary caution, could damage the product, the workshop or the environment.
	WARNING Procedures which, if not carried out with the necessary caution, may damage the product or cause serious personal injury.
	CAUTION Denotes risk of electric shock.
	WARNING! Fire hazard! Important warning to prevent fire.
	Personal protective equipment (PPE) Instruction to use respiratory protection when you do service, maintenance and repair jobs, as well as during functional testing. We recommend to use a half-face respirator according to EN 149:2001 + A1:2009, class FFP3 (Directive 89/686/EEC).
	Personal protective equipment (PPE) Instruction to use protective gloves when you do service, maintenance and repair jobs.

Text indicators

Listings indicated by "-" (hyphen) concern enumerations. Listings indicated by "•" (bullet point) describe steps to perform.

Product indications / Abbreviations

<u>Product type:</u>	<u>Equals to:</u>
- ControlPro/Panel	Panel
- ControlPro/HMI	HMI
- SCS-Diluter PRO	SCS-Diluter

1 INTRODUCTION

1.1 Identification of the product

The product consists of various components, the identification plates of which contain the following data:

- product name
- serial number
- supply voltage and frequency
- power consumption

1.2 General description

1.2.1 Filter system

The SCS-Diluter is a free-standing general filtration system that prevents accumulation of welding fume by continuous

filtration of polluted air. It consists of a central filter system, a fan in sound-absorbing case, an outlet unit with adjustable outlet nozzles, a silencer and control equipment.

1.2.2 Control equipment

The SCS-Diluter is supplied with the ControlPro, which is an intelligent control panel with an integrated frequency inverter and a separate HMI¹. This system controls the fan and the filter cleaning system based on compressed air.

1.3 System overview

Fig. 1.1

- A Junction box
- B Filter system (type SCS-Diluter)
- C HMI
- D Panel [control panel]
- E Extraction fan (type SIF-1200)

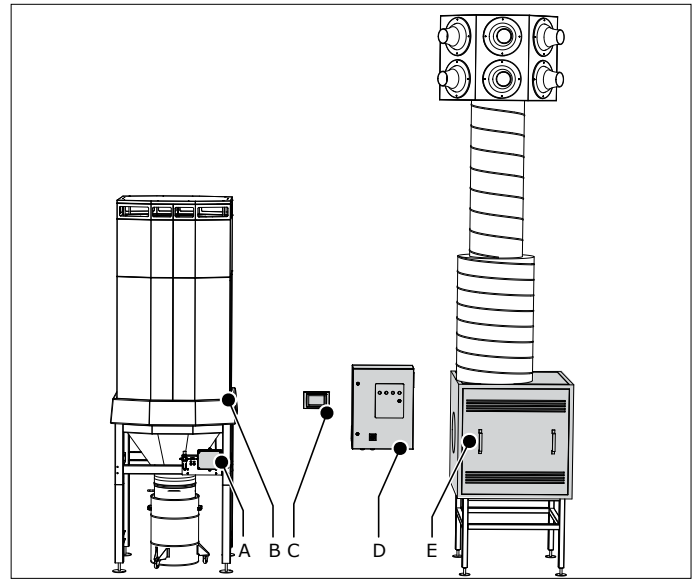

Fig. 1.1 SCS-Diluter PRO

1.4 Options and accessories

The following products are available as an option and/or accessory:

- Panel → HMI cable 30 or 60 m (98 or 197 ft), instead of standard length 15 m (49 ft)
- LightTower
- BoosterFan | Additional fan to increase the airflow

1.5 Technical specifications

1.5.1 SCS-Diluter (filter system)

Dimensions	refer to Fig. I on page 20
Required compressed air quality	dry and oil-free according to ISO 8573-3 class 6
Required pressure	6 bar (90 psi)
Compressed air connection	quick connect coupling Ø 9 mm (CEJN 320)
Compressed air consumption	max. 150 nl/min. (5.3 ft ³ /min.) (depending on the degree of saturation of the filter)
Unrestricted airflow	max. 12.000 m ³ /h (7063 CFM)
Power consumption fan	7,5 kW (10 HP)
Connection voltage	400V/3ph/50Hz 480V/3ph/60Hz 600V/3ph/60Hz
Insulation class fan	F with PTC
Protection class	IP 54
Weight (net)	800 kg (1764 lbs)

1. Human Machine Interface

1.5.2 Filter cartridges

The SCS-Diluter is available with two different types of filter cartridges:

Product type:	SCS-Diluter PRO	SCS-Diluter PRO W3
Filter cartridges	FCC-150 (standard)	FCC-150/HE (high efficiency)
Filter material	cellulose fibres provided with precoat	cellulose and polyester fibres
Filter surface area	2 x 75 m ² (2 x 807 ft ²)	2 x 75 m ² (2 x 807 ft ²)
Filter class (according to DIN EN 60335-2-69)	M	M
Operational airflow (max.)	9000 m ³ /h (5,297 CFM)	8000 m ³ /h (4,709 CFM)
W3 compliant	no	yes

1.5.3 ControlPro (control equipment)

Panel

Dimensions	refer to Fig. II on page 20
Weight	55 kg (121 lbs)
Material of housing	sheet metal
Protection class	IP 54
Input voltage	400V3ph/50Hz 480V/3ph/60Hz 600V/3ph/60Hz
Internal operating voltage	24 VDC (controls) 115V / 230V (cooling fan)
Power consumption	max. 7,5 kW
Internal pressure sensors	2x integrated pressure sensor (for filter pressure and fan pressure)
Approvals & certificates	400V: CE 480V / 600V: cULus (UL 508A)

HMI

Dimensions	255 x 165 x 125 mm (10.0 x 6.5 x 4.9 in.)
Weight	900 g (2 lbs.)
Material of housing	PC/ABS
- flammability standard	- UL94 V-0
Operating voltage	24 VDC (+/- 15%)
Power consumption	- display off: nom. 4 W - display on: max. 5 W
External connectors	- CAN + power (connection to Panel) [M12-5p shielded connector] - USB 2.0 (host only) [USB A receptacle, with dust cap] - ethernet 10/100 Mbit/s [RJ45, shielded, with dust cap]
Display:	
- size	- 7"
- type	- resistive touch screen
- brightness	- 300 cd/m ²
- colour	- 262K
- resolution	- 800 x 480 pixels
Approvals & certificates	CE

1.6 Ambient conditions

1.6.1 SCS-Diluter (filter system)

Operating temperature:	
- min.	+5°C (41°F)
- nom.	+20°C (68°F)
- max.	+45°C (113°F)
Max. relative humidity	80%
Suitable for outdoor use	no

1.6.2 ControlPro (control equipment)

Panel

Ambient temperature:	Pressure sensors:	
	internal	external (option)
	- min.	-20°C (-4°F)
	- nom.	+20°C (68°F)
- max.	+50°C (122°F)	+50°C (158°F)
Max. relative humidity	80%	
Suitable for outdoor use	no	

HMI

Ambient temperature:	0°C (32°F)
	- min.
	- nom.
	- max.
Max. relative humidity	80%
Suitable for outdoor use	no

2 PRODUCT DESCRIPTION

2.1 Components

The product consists of the following main components and elements:

2.1.1 SCS-Diluter

Fig. 2.1

- A Outlet unit with 6 adjustable outlet nozzles
- B Vertical duct 1,5 m (5 ft) / Ø 500 mm (19.7 in.)
- C Silencer
- D Extraction fan (SIF-1200) in sound absorbing case
- E HMI
- F Panel (control panel incl. frequency inverter)
- G Fan frame
- H Adjusting feet (8x)
- I Junction box
- J Dustbin
- K Filter base frame
- L Filter base
- M Air inlet module
- N Filter cartridge FCC-150 (2-piece)
- O RoboCleanPlus™ automatic filter cleaning system

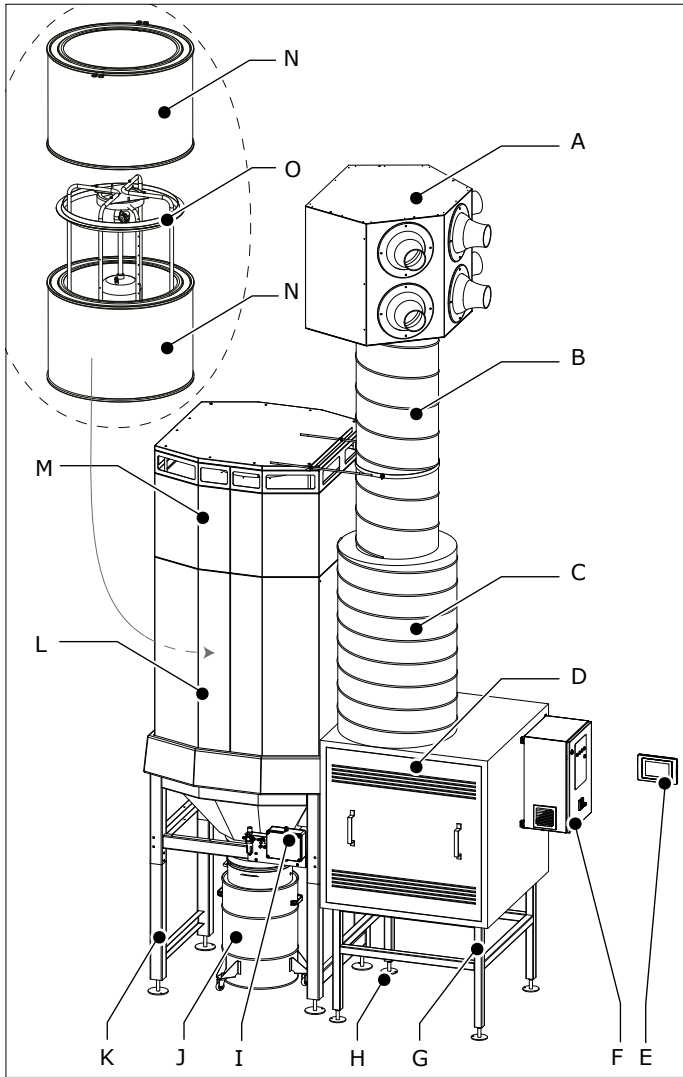

Fig. 2.1 Main components and elements

2.1.2 Control equipment

Panel

Fig. 2.1

High voltage compartment

- A VFD (frequency inverter)
- B Transformer
- C Cooling fan
- D Thermostat
- E Switch mode power supply
- F Circuit protectors²
- G Main switch (interior parts)

Low voltage compartment

- H PC board
- I Manual controls

Outside

- J Status panel
- K Main switch (exterior parts)

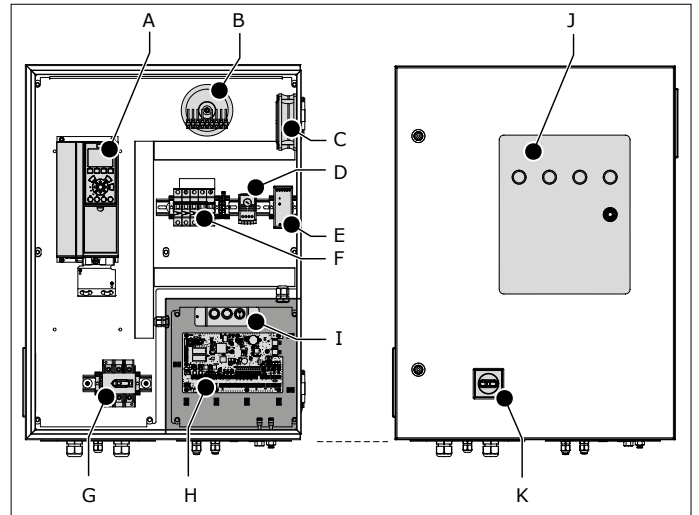

Fig. 2.1 Main components Panel

HMI

Fig. 2.2

- A Touch screen
- B Mounting bracket

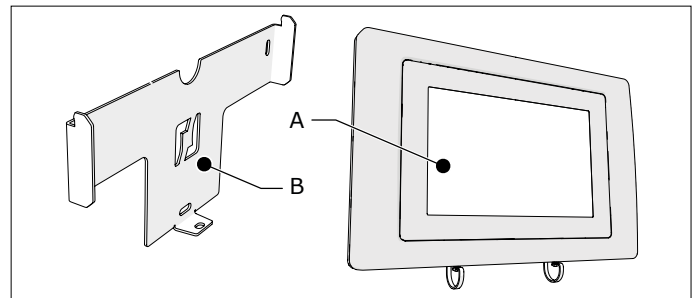

Fig. 2.2 Main components HMI

Connection cables

- Panel → HMI cable
- motor cable
- PTC cable
- control cable

2.2 Operation

2.2.1 SCS-Diluter

The air -that contains welding fume- is extracted through the air inlet module on top of the unit. The larger particles and any sparks are separated by a labyrinth-shaped spark arrester. Subsequently the air is cleaned by the main filter cartridges. The air then passes the extraction fan and a duct silencer. The clean air is blown back into the workshop by the outlet unit with adjustable nozzles.

The unit contains the RoboCleanPlus™ system for automatic sectionwise cleaning of the filter cartridges by compressed air. The dust and dirt particles end up in the dustbin underneath. The fan speed is pressure controlled.

Apart from air cleaning, the system optimises the present natural ventilation (draught) and/or forced ventilation (roof/wall fans) system and equally distributes the present welding fume to reduce the background concentration of welding fume in the workshop.

2.2.2 ControlPro

ControlPro is an intelligent platform that controls the filter system as well as the connected extraction fan. It contains an extensive feature package to monitor and arrange the RoboCleanPlus™ filter cleaning system, the required airflow

2. CE (400V): circuit breakers | UL (480/600V): fuses

and the corresponding fan speed. By means of the user-friendly HMI you can program all desired parameters. The HMI gives a clear insight into the system status and performance at all times.

ControlPro allows for remote access via a network connection.

3 SAFETY INSTRUCTIONS

General



The manufacturer does not accept any liability for damage to the product or personal injury caused by ignoring of the safety instructions in this manual, or by negligence during installation, use, maintenance, and repair of the product mentioned on the cover of this document and any corresponding accessories. Specific working conditions or used accessories may require additional safety instructions. Immediately contact your supplier if you detect a potential danger when using the product.

The user of the product is always fully responsible for observing the local safety instructions and regulations. Observe all applicable safety instructions and regulations.

User manual

- Everyone working on or with the product, must be familiar with the contents of this manual and must strictly observe the instructions therein. The management should instruct the personnel in accordance with the manual and observe all instructions and directions given.
- Never change the order of the steps to perform.
- Always keep the manual with the product.

Pictograms and instructions on the product (if present)

- The pictograms, warning and instructions attached to the product are part of the safety features. They must not be covered or removed and must be present and legible during the entire life of the product.
- Immediately replace or repair damaged or illegible pictograms, warnings and instructions.

Users

- The use of this product is exclusively reserved to authorised, trained and qualified users. Temporary personnel and personnel in training can only use the product under supervision and responsibility of skilled engineers.
- Use common sense. Stay alert and keep your attention to your work. Do not use the product when you are under the influence of drugs, alcohol or medicine.
- The product is not to be used by children or persons with reduced physical, sensory or mental capabilities, or lack of experience and knowledge, unless they have been given supervision or instruction.
- Children must be supervised not to play with the product.

Intended use³

The SCS-Diluter has been designed exclusively for extracting and filtering gases and particles which are released during the most common welding processes.

The ControlPro has been designed exclusively as control equipment for use with a filter system type SCS-Diluter of Plymovent including the connected extraction fan.

3. "Intended use" as explained in EN-ISO 12100-1 is the use for which the technical product is suited as specified by the manufacturer, inclusive of his directions in the sales brochure. In case of doubt it is the use which can be deduced from the construction, the model and the function of the technical product which is considered normal use. Operating the machine within the limits of its intended use also involves observing the instructions in the user manual.

Using the product for other purposes is considered contrary to its intended use. The manufacturer accepts no liability for any damage or injury resulting from such use. The product has been built in accordance with state-of-the-art standards and recognised safety regulations. Only use this product when in technically perfect condition in accordance with its intended use and the instructions explained in the user manual.

Technical specifications

The specifications given in this manual must not be altered.

Modifications

Modification of (parts of) the product is not allowed.

Product combinations

If the product is used in combination with other products or machines, the safety instructions in the documentation of these products also apply.

	<p>WARNING! Fire hazard! Do not use the product for:</p> <ul style="list-style-type: none"> - extracting and/or filtering flammable, glowing or burning particles or solids or liquids - extracting and/or filtering of aggressive fumes (such as hydrochloric acid) or sharp particles - extracting and/or filtering dust particles which are released when welding surfaces treated with primer - sucking cigarettes, cigars, oiled tissues, and other burning particles, objects, and acids
	<p>WARNING Do not use the product for:</p> <ul style="list-style-type: none"> - oil mist - paint mist - extraction of hot gases (more than 45°C/113°F continuously) - explosive environments or explosive substances/gases <p><i>Note: this list is not all-embracing.</i></p>

Installation



- The installation of this product is exclusively reserved to authorised, trained and qualified engineers.
- Electric connection to be executed in accordance with local requirements. Ensure compliance with the EMC regulatory arrangements.
- During installation, always use Personal Protective Equipment (PPE) to avoid injury. This also applies for persons who enter the work area during installation.
- Use sufficient climbing gear and safety guards when working on a higher level than 2 meter (6.5 ft) (local restrictions may apply).
- Do not install the product in front of entrances and exits which must be used for emergency services.
- Mind any gas and water pipes and electric cables.
- Make sure that the wall, ceiling or support system are strong enough to carry the product.
- Ensure the workspace is well illuminated.
- Use common sense. Stay alert and keep your attention to your work. Do not install the product when you are under the influence of drugs, alcohol or medicine.
- Make sure that the workshop, in the vicinity of the product, contains sufficient approved fire extinguishers (suitable for fire classes ABC).
- Air containing particles such as chromium, nickel, beryllium, cadmium, lead etc., which is a health hazard, should never be recycled. This air must always be brought outside the working area.

Use

- Inspect the product and check it for damage. Verify the functioning of the safety features.
- During use, always use Personal Protective Equipment (PPE) to avoid injury. This also applies for persons who enter the work area.
- Check the working environment. Do not allow unauthorised persons to enter the working environment.
- Protect the product against water and humidity.
- Make sure the room is always sufficiently ventilated; this applies especially to confined spaces.

Service, maintenance and repairs

- Obey the maintenance intervals given in this manual. Overdue maintenance can lead to high costs for repair and revisions and can render the guarantee null and void.
- During service, maintenance and repair jobs, always use Personal Protective Equipment (PPE) to avoid injury. This also applies for persons who enter the work area.
- Always use tools, materials, lubricants and service techniques which have been approved by the manufacturer. Never use worn tools and do not leave any tools in or on the product.
- Safety features which have been removed for service, maintenance or repairs, must be put back immediately after finishing these jobs and it must be checked that they still function properly.
- Use sufficient climbing gear and safety guards when working on a higher level than 2 meter (6.5 ft) (local restrictions may apply).

	ATTENTION Service, maintenance and repairs should only be performed in accordance with directive TRGS 560 by authorised, qualified and trained persons (skilled) using appropriate work practices.
	WARNING Before carrying out service, maintenance and/or repair jobs: <ul style="list-style-type: none">- fully disconnect the machine from the mains- disconnect compressed air supply
	WARNING Always wear face mask and gloves during filter exchange/cleaning. Industrial vacuum cleaner used during service and maintenance should meet dust class H according to EN 60335-2-69.

4 INSTALLATION

4.1 Tools and requirements

You need the following tools to install the system:

- lifting equipment (e.g. fork-lift truck, crane)
- climbing gear (e.g. scissor lift)
- cordless drill
- step drill
- wrench (metric sizes 10-13-17)
- screw driver
- level
- mains cable 4 mm² (AWG 12); 3 cores + mass
- self-tapping screws
- duct tape
- flowmeter
- basic tools
- tools for electrical connections⁴

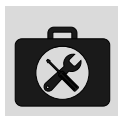

4.1.1 To be sourced locally

Mounting material⁵:

- to install the Panel to the fan housing or to the wall (hardware max. Ø 10 mm)
- to install the HMI to the wall (head height of screws max. 6 mm, Ø max. 4 mm)



Connection cables⁶:

- refer to Table I on page 26 for the cable specifications

If necessary:

- additional cable glands M16

Optional (for remote access to HMI via network):

- ethernet cable, min. CAT 5E shielded

4.2 Unpacking

Check that the product is complete. The package contains:



SCS-Diluter | Filter system

Filter system

- filter base; including filter cartridges, junction box and pressure reducing valve
- filter base frame (two-piece)
- dustbin + flange
- dustbin lid
- dustbin trolley

Inside the dustbin:

- bush
- adapter Ø 400 mm (15.7 in.)
- duct connector Ø 400 mm (15.7 in.) with KEN-LOK sealing
- mounting material for base frame

Air inlet module

- lid
- air inlet
- labyrinth spark arrester (upper part)
- labyrinth spark arrester (lower part)
- top-piece
- mounting material

Extraction fan

- fan
- fan mounting frame

Inside the fan housing:

- cable glands
- electric connection material

Outlet unit

- silencer
- duct connector Ø 500 mm (19.7 in.) with KEN-LOK sealing (2)
- duct 1,5 m Ø 500 mm (5 ft Ø 19.7 in.)
- outlet unit with nozzles
- support bracket (two-piece)
- angle iron
- screw stud M10 (2)
- mounting material

ControlPro | Control equipment

- Panel (control panel), incl. double-bit key, mounting brackets (4) and mounting material
- HMI, incl. bracket, locking screw and ethernet field connector (IP 67)

4. E.g. heat gun, cable stripping tool

5. The type of mounting material depends on the wall type

6. Number and type of cables depend on the selected options and control equipment

Connection cables

- motor cable: 4-cored shielded cable 4 mm² (AWG 12)
- PTC cable: 2-cored shielded cable 0,75 mm² (AWG 18)
- Panel to HMI cable, incl. heat shrinking tubes
- control cable (from Panel to junction box)
- pneumatic hoses, incl. mounting material:
 - 2x10 m (for filter pressure)
 - 10+1 m (for fan pressure)
- electrical diagram



If parts are missing or damaged, contact your supplier.

4.3 Positioning

You can install the SCS-Diluter on the floor or on a platform. Make sure that the outlet nozzles can be directed to the welding fume layer without obstruction.

Depending on the circumstances, it might be necessary to use a longer or shorter duct than the 1,5 m (5 ft) one which is standard supplied.



Make sure that there is sufficient space (min. 750 mm/2.5 ft) above the filter system in view of filter exchange.

- Refer to Fig. III on page 21 for positioning examples.

4.4 Mounting of the filter system

To install the filter system, do the following.

4.4.1 Air inlet to filter base

Fig. 4.1

- Put a locknut (E) onto the screw studs (D).
- Install the air inlet (F) to the top-piece (G) with a screw stud (D), a distance tube (C), 2 washers (B) and another locknut (A) at each corner. Fasten securely.

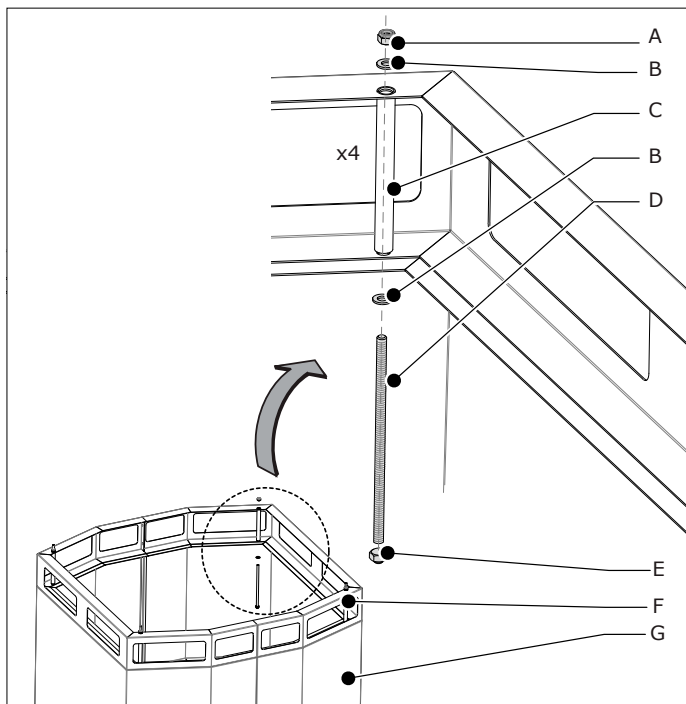

Fig. 4.1 Mounting of the air inlet

Fig. 4.2

- Put the top-piece (A) on the filter base (B).
- Install the top-piece with 4x bolt M8, 8x washer and 4x nut.



ATTENTION

During mounting, do **not** stand in the middle section of the filter cover plate. Only the rim is strong enough for standing (max. 100 kg/220 lbs).

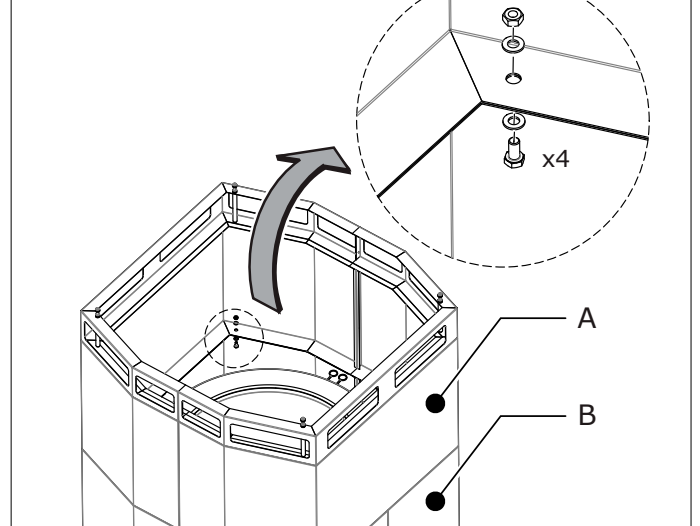

Fig. 4.2 Mounting of the top-piece on the filter base

Fig. 4.3

- Put the spark arrester (lower part) (C) on the filter cartridge.
- Put the spark arrester (upper part) (B) on top of the lower part.
- Put the lid (A) on the spark arrester. Insert the screw studs through the corner holes of the lid.
- Install the lid on the air inlet module (E) with the 4x washer + 4x nut (D).

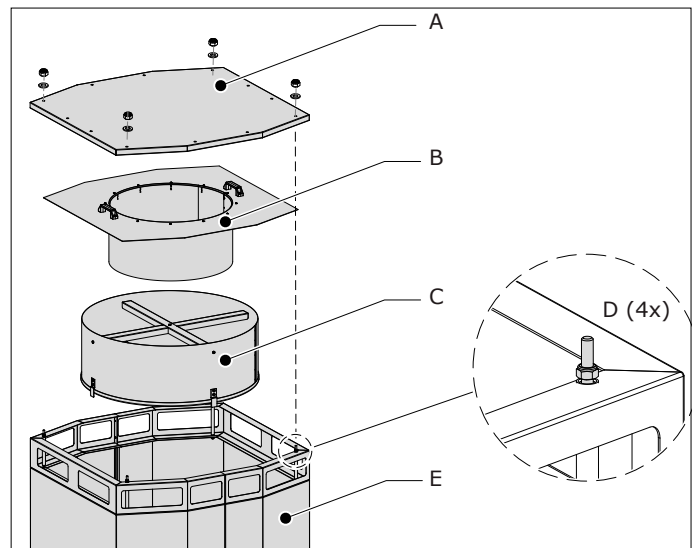

Fig. 4.3 Labyrinth spark arrester

4.4.2 Filter base on frame

The filter base frame consists of two parts.

- Extend the adjusting feet min. 70 mm (7.5 in.).

**ATTENTION**

If the adjusting feet are extended less than 70 mm (7.5 in.), the dustbin will not fit.

Fig. 4.4

- Insert the connectors (B) halfway in the frame legs (C).
- Insert bolts + washers in the lower holes. Tighten the bolts loosely.
- Put the filter base (A) on the legs.
- Insert bolts + washers in the upper holes. Tighten all bolts firmly.

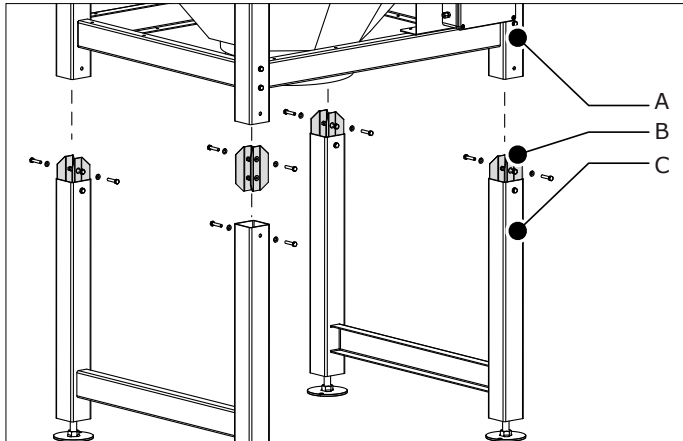

Fig. 4.4 Mounting of the filter base frame

4.4.3 Junction box

The junction box is pre-mounted on the filter base frame. It is possible to change the position of the junction box to any other side of the frame. For this purpose each side of the frame contains pre-drilled holes.

- If desired/necessary, change the position of the junction box.
- Put the filter system on its final position.

4.4.4 Extraction fan

Fig. 4.5

- Put the extraction fan (A) on the fan frame (B).

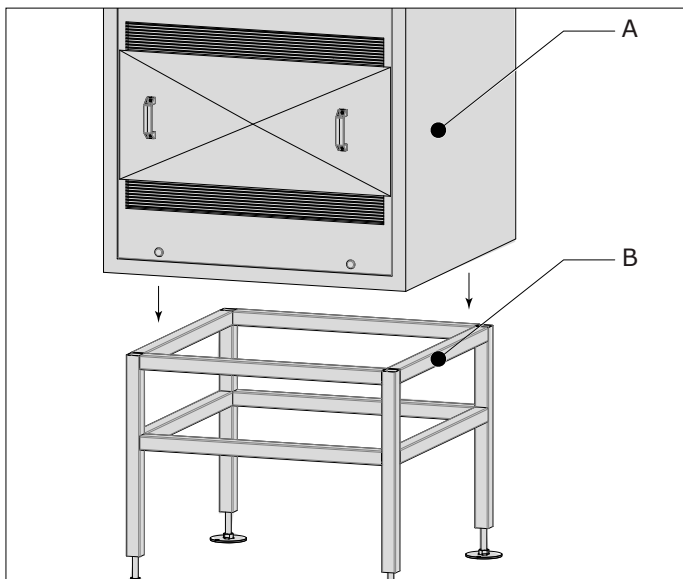

Fig. 4.5 Fan on frame

In the standard configuration, the inspection cover is located on the front side. It is possible to change the inspection cover to the rear.

- If desired/necessary, change the position of the inspection cover.

4.4.5 Connection of the filter system to the fan

The outlet of the filter system is fitted with a connection ring. Other necessary parts:

- adapter Ø 400 mm (15.7 in.)
- duct connector Ø 400 mm (15.7 in.) with KEN-LOK sealing

Fig. 4.6

- Put the adapter (B) on the connection ring (A). Do not slide the adapter all the way over the ring, but leave approx. 20 mm (1 in.).



Disassemble the connection ring from the filter base to facilitate assembly. Use a cordless drill with a long pin to reinstall.

- Attach the adapter to the connection ring with 4 self-tapping screws.
- Make this assembly airtight with duct tape (preferably two laps).
- Install the duct connector (C) to the adapter (B). Attach it with 4 self-tapping screws.
- Install the fan (D).
- Make sure that the fan inlet and the filter outlet are on the same level. If necessary, adjust the adjusting feet.
- Slide the duct connector all the way inside the inlet opening of the fan.

**ATTENTION**

Make sure that both the filter system and the extraction fan are level. To check this, put the level in vertical position on the filter base (so not on the frame).

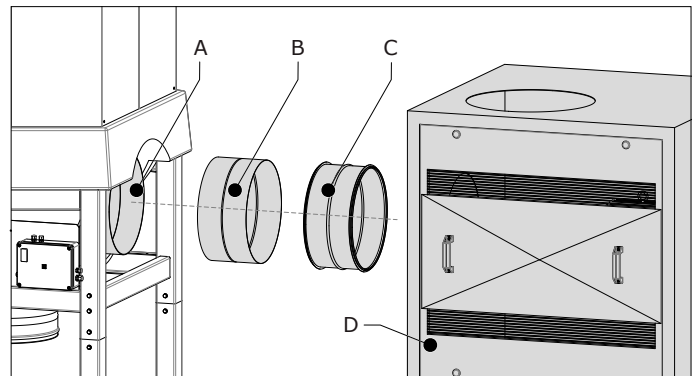

Fig. 4.6 Connection of the filter system to the fan

4.4.6 Silencer

Fig. 4.7

- Put a duct connector (C) in the outlet opening (D) of the fan. Attach it with 8 self-tapping screws.
- Put the other duct connector (A) on top of the silencer (B). Attach it with 8 self-tapping screws.
- Put the silencer on the lower duct connector (C). Attach it with 8 self-tapping screws.

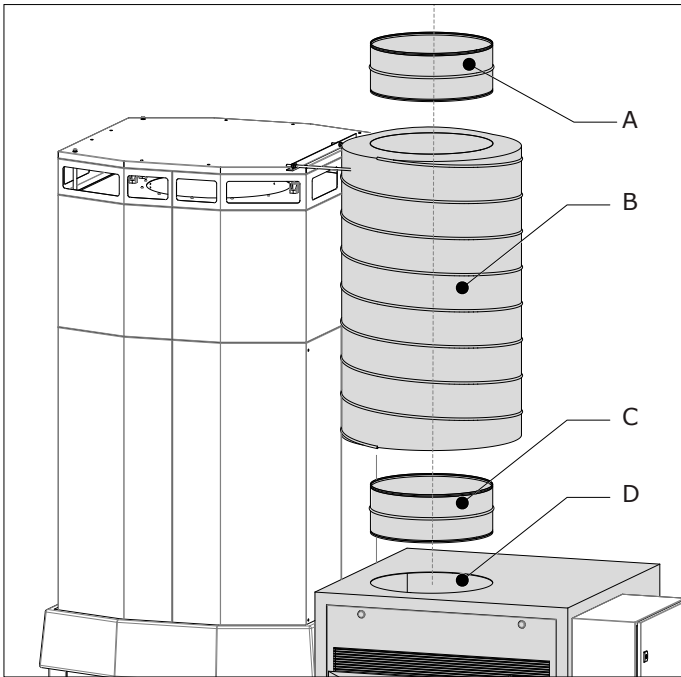

Fig. 4.7 Mounting of the silencer

4.4.7 Outlet unit with adjustable nozzles

- Determine the direction of the outlet unit and the airflow direction of the individual nozzles.



Depending on the specific circumstances, it might be necessary to partly or fully close one or more nozzles.

Fig. 4.8

- Put the outlet unit (A) on the duct (B). Attach it with 4 self-tapping screws.
- Put the duct on the silencer. Attach it with 8 self-tapping screws.

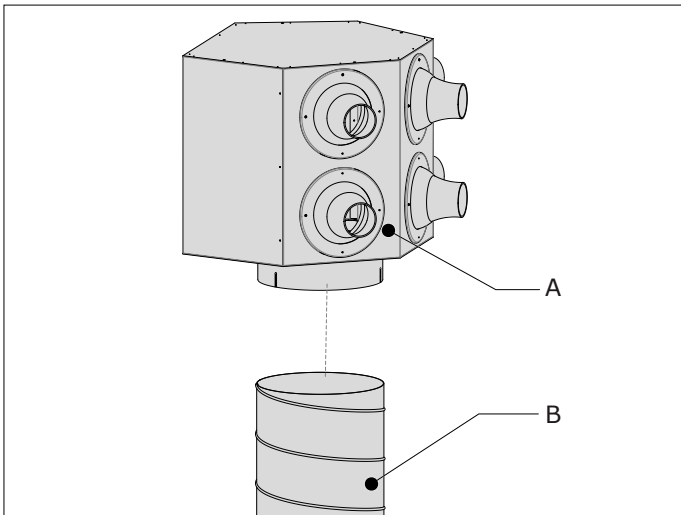

Fig. 4.8 Outlet unit on duct

You must attach the duct to the filter system to strengthen the configuration. Instead of fastening to the filter system, you can attach the duct to the wall as well.

To attach the duct to the filter system, do the following.

Fig. 4.9

- Install the angle iron (B) on top of the air inlet module with the supplied mounting material.

- Attach the duct to the air inlet module with the support brackets and screw studs (A).
- Make sure that the duct and the filter base are parallel to each other.

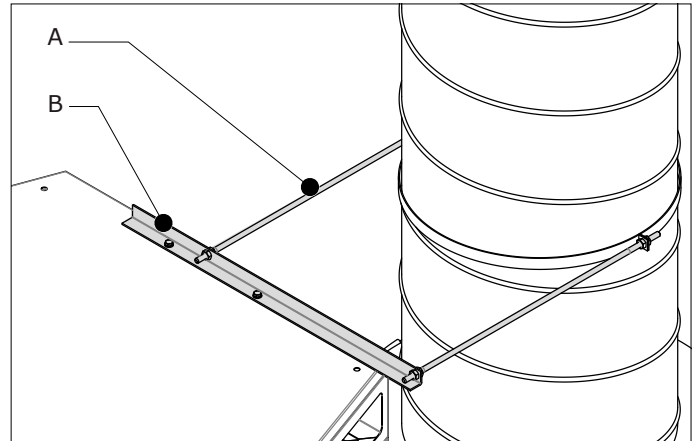

Fig. 4.9 Fastening of the duct

4.5 Pneumatic connection



Fig. 4.10

- Connect a compressed-air line to the pressure reducing valve (A) next to junction box CB-SCS. Attach the line securely.



WARNING

Prevent damage to the cleaning mechanism. Make sure that the compressed air is free from oil and moisture (ref. ISO 8573-3 class 6).

4.5.1 Filter pressure sensor

Fig. 4.10

- Connect two pneumatic hoses to the + and - (B+C).

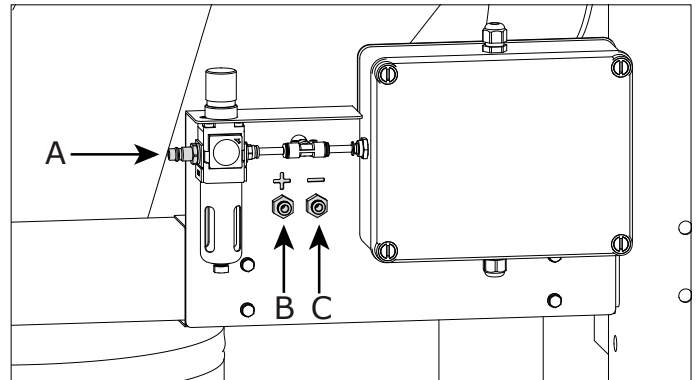

Fig. 4.10 Compressed air connection

Fig. 4.12

- Connect the other side of the pneumatic hoses to the corresponding push-in fittings (A) in the bottom plate of the Panel.

4.5.2 Fan pressure sensor

Fig. 4.11

- Determine the position of the pressure sensor in the vertical duct. Best position: approx. 500 mm (20 in.) below the outlet unit.
- Drill two holes \varnothing 10 mm (0.4 in.) in the vertical duct at the indicated positions (A+B).
- Connect the pneumatic hose (D) with T-connector (C) to the duct with the supplied connection material.

Fig. 4.12

- Connect the other side of the pneumatic hose to the corresponding push-in fitting (B)⁷ in the bottom plate of the Panel.

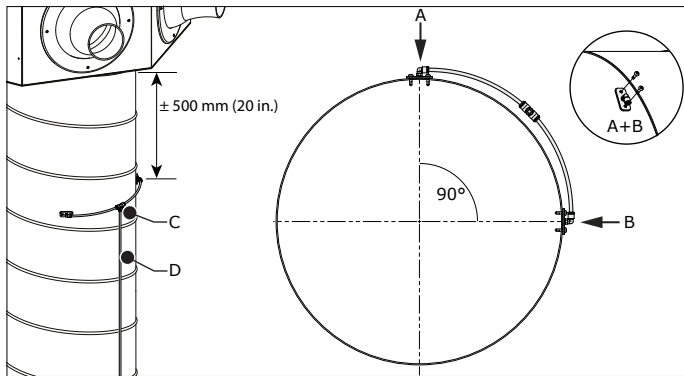

Fig. 4.11 Mounting of the pressure sensor

4.5.3 Connection of pneumatic hoses to the Panel

Refer to paragraph 4.5.1 and 4.5.2.

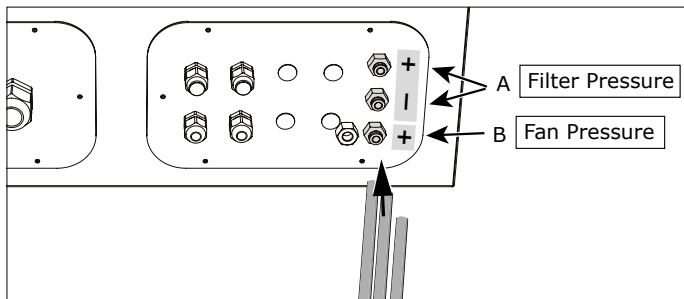

Fig. 4.12 Connection of pneumatic hoses to the Panel

4.6 Mounting of the control equipment

You must install the Panel and HMI at a clearly visible and accessible position.



	ATTENTION Do not expose any component of ControlPro to vibrations or heat radiation.
	We recommend to install the Panel on the side of the fan housing.

4.6.1 Panel

Fig. 4.13

- Attach the mounting brackets (A) to the Panel with the supplied mounting material (B).

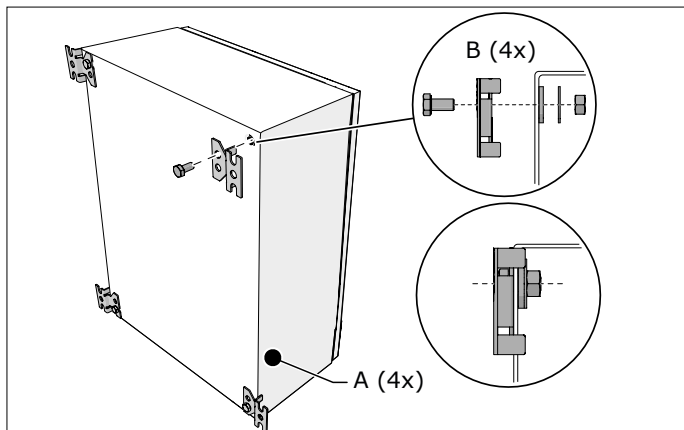

Fig. 4.13 Mounting brackets

7. Push-in fitting - (minus) remains unused

Fig. 4.14

- Install the Panel to the fan housing or to the wall. Make sure that it is level.

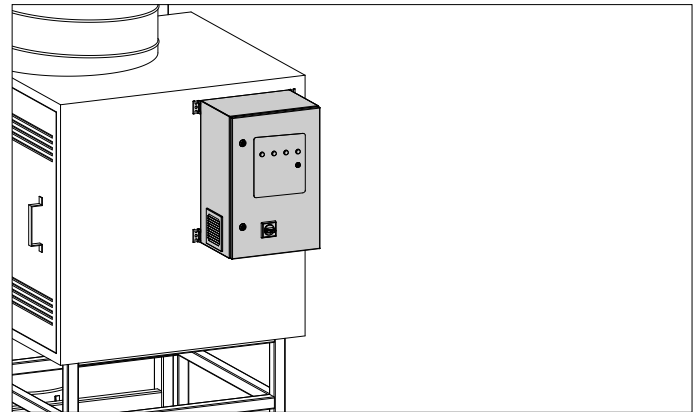

Fig. 4.14 Mounting of the Panel to the fan housing

The housing contains two removable bottom plates, that contain the following cable glands and connectors:

Fig. 4.15

High voltage compartment (left bottom plate)

- A Cable gland M25 for the motor cable
- B Cable gland M16 for the PTC cable
- C Cable gland M25 for the mains cord

Low voltage compartment (right bottom plate)

- D Universal cable glands M16 (4)
- E Push-in fittings (3) for the pressure tubes⁸

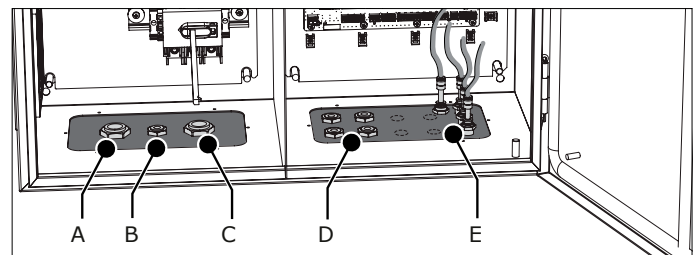

Fig. 4.15 Bottom plates

Table I on page 26 gives an overview of the necessary and optional cables that you need to install the system.

- Depending on the selected options, determine the number and type of cables that you need.

If the number exceeds 4 cables (excluding the mains cord), you must install additional cable glands in the right bottom plate. In that case, do the following.

Fig. 4.16

- (1) Loosen the pneumatic hoses from the push-in fittings on the inside of the Panel.
- (2) Loosen and (3) remove the right bottom plate.
- Open the necessary number of knock-out holes⁹.
- (4) Put additional cable glands M16 (E) in the bottom plate and tighten them.
- Install the bottom plate.
- Fasten the pneumatic hoses to the push-in fittings.

	WARNING You must remove the bottom plate to put additional cable glands to avoid damage to the interior parts of the Panel.
--	---

8. Fan pressure + | Filter pressure + and -

9. Max. 4

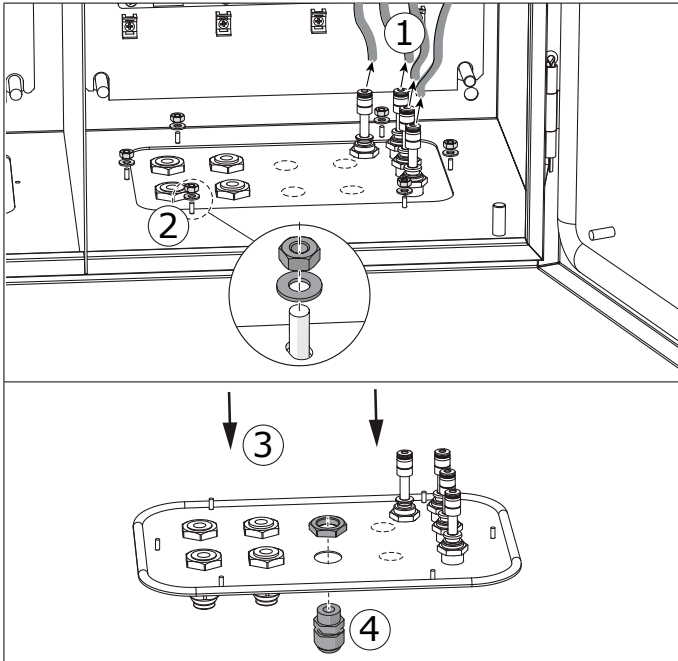

Fig. 4.16 Additional cable glands (optional)

4.6.2 HMI

Fig. 4.17

- Loosen the locking screw (C) and the HMI (B) from the bracket (A).
- Install the bracket to the wall. Use all 3 mounting points and make sure that it is level.
- Put the HMI on the bracket.

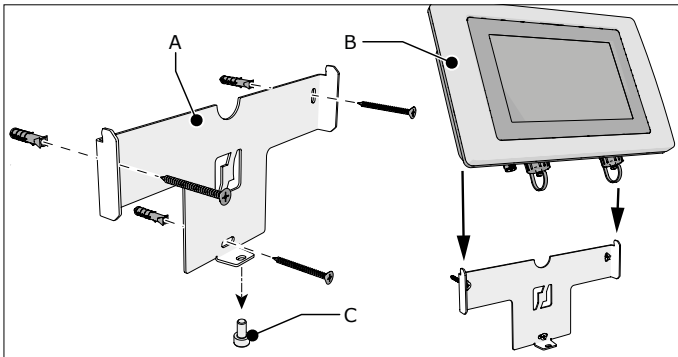

Fig. 4.17 Mounting of the HMI

Fig. 4.18

- Attach the HMI with the locking screw (A).
- Connect the HMI cable (C) to the CAN connector (B) and tighten it.

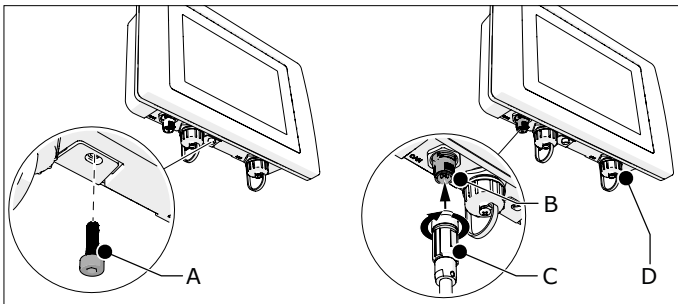

Fig. 4.18 Locking screw and HMI cable

Optional:

Fig. 4.19

- Connect the supplied ethernet field connector (B) to the ethernet cable (A).
- Remove the dust cap (refer to Fig. 4.18D) and put the ethernet cable in the corresponding LAN port.

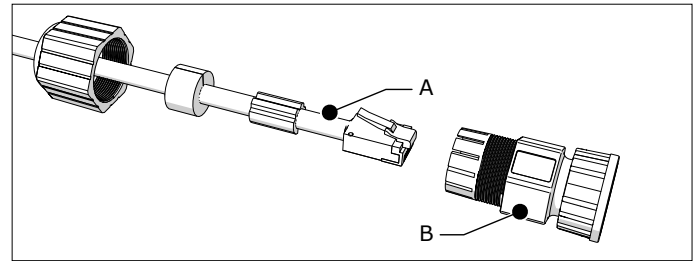

Fig. 4.19 Ethernet field connector

4.7 Electric connection

This chapter describes the electric connection of all necessary and optional components to the Panel.



Depending on the specific configuration of the filter system, some of the connections on the PC board inside the Panel remain unused. The PC board contains detachable screw terminal blocks ("connectors").

Table I on page 26 gives an overview of the necessary and optional cables¹⁰ that you need to install the system.



WARNING

- Shorten excessive cable lengths. A coil or bundle of cables can cause electromagnetic interference.
- Make sure that you connect the wiring in the correct way. Wrong wiring may cause permanent damage to the PC board.
- Use cable glands to insert cables into the Panel.
- Keep the blanking plugs on the cable glands that are not in use to avoid pollution of the Panel.



- For all connections, also refer to the separately supplied electrical diagram.
- Refer to Table II on page 26 for a specification of the digital inputs (high/low).



General instructions to connect a cable to a certain connector (unless otherwise stated)

Wire stripping:

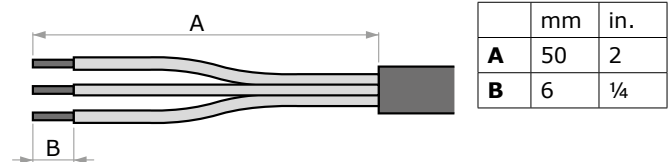

10. Recommended cable specifications; use cables with a max. wire diameter 1,5 mm² (AWG 16)

- (1) Put the cable through a cable gland M16 into the Panel.
- (2) Carefully remove the connector from the PC board. Pull the connector in a *horizontal* direction.
- Cut the cable to the correct length and strip the wires.

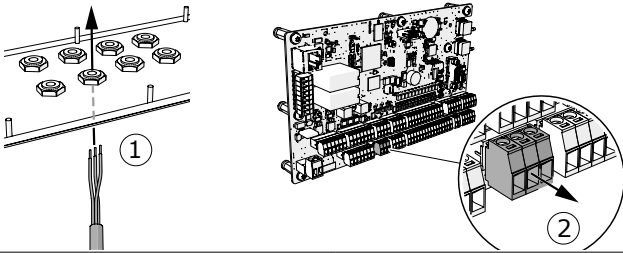

Shielded cables only:

- Put a shrink tube on the drain wire (A) and the cable jacket (B).
- Use a heat gun (C) to tighten the shrink tube.

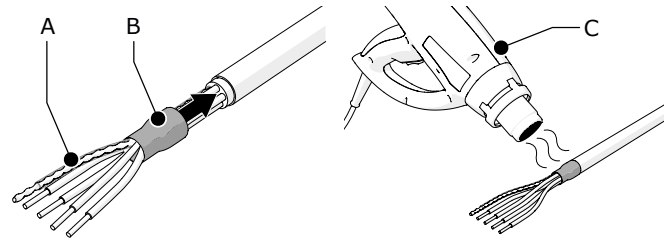

All cables:

- (3) Put the wires into the connector.
- (4) Tighten the screws.
- (5) Put the connector back on the PC board.
- Tighten the cable gland.

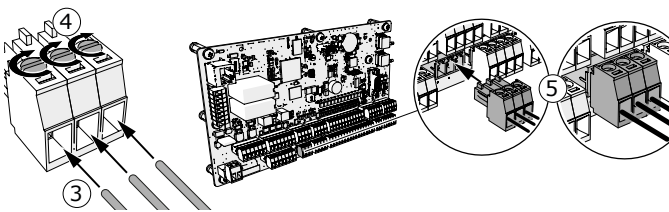

Detachable screw terminal block ("connector")

Overview of connections:

Ref. / Cable #	E = Electric P = Pneumatic	For connection of:	To:
1	Panel → HMI	Panel	HMI
5	Mains cord	Panel	Mains
20	Control cable	CB-SCS	Panel
23	Motor cable	Fan motor	Panel (frequency inverter)
24	PTC cable		
A	Pneumatic hose	CB-SCS	Compressed air supply
B	Filter pressure tube (+)	CB-SCS	Panel (push-in fittings)
C	Filter pressure tube (-)		
D	Fan pressure tube (+)	Panel	Vertical duct

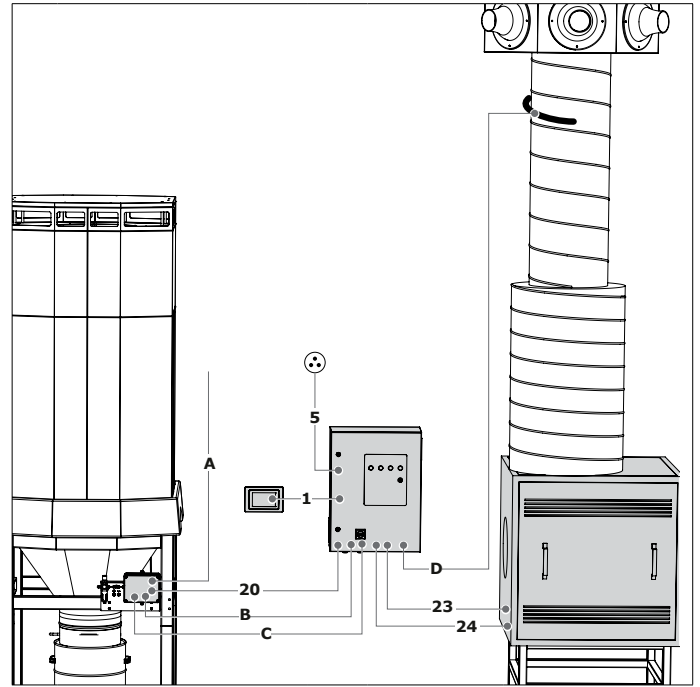

4.7.1 Mains cord (cable #5)

To install the mains cord to the Panel, do the following.



CAUTION

High voltage connection

Fig. 4.20

- Put the mains cord (B) through the right cable gland.
- Connect it to connectors L1, L2 and L3 on the terminals of the main switch (A) and to PE¹¹ on the left connector.
- Fasten the cable gland.

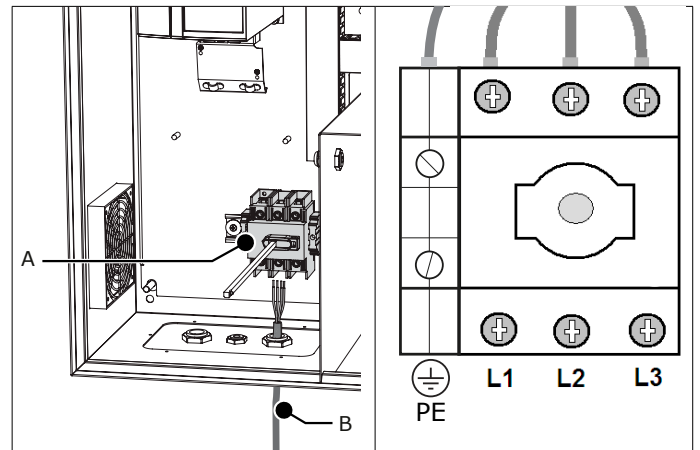

Fig. 4.20 Mains cord

4.7.2 Motor cable + PTC cable



The motor cable and the PTC cable are supplied in the SCS-Diluter PRO package;
 - motor cable: 4-cored shielded cable 4 mm²
 - PTC cable: 2-cored shielded cable 0,75 mm²

To install the motor cable and PTC cable to the Panel, do the following.

11. PE = Protective Earth

Fig. 4.21

- Put the motor cable (A) through the left cable gland.
- Put the PTC cable (B) through the middle cable gland.

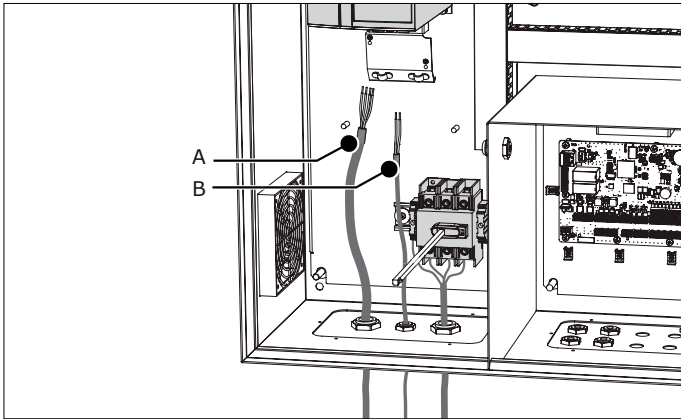

Fig. 4.21 Motor cable and PTC cable

To connect the motor cable and the PTC cable to the VFD (frequency inverter), do the following.

Fig. 4.21 + Fig. 4.24 (electrical diagram)

Connection of the motor cable to the VFD

- Remove the front cover (lower part) of the VFD inside the Panel.
- Remove the outer insulation from the motor cable at the position of the EMC clamp (A).
- Connect the motor cable in accordance with the electrical diagram.
- Fasten the EMC clamp.

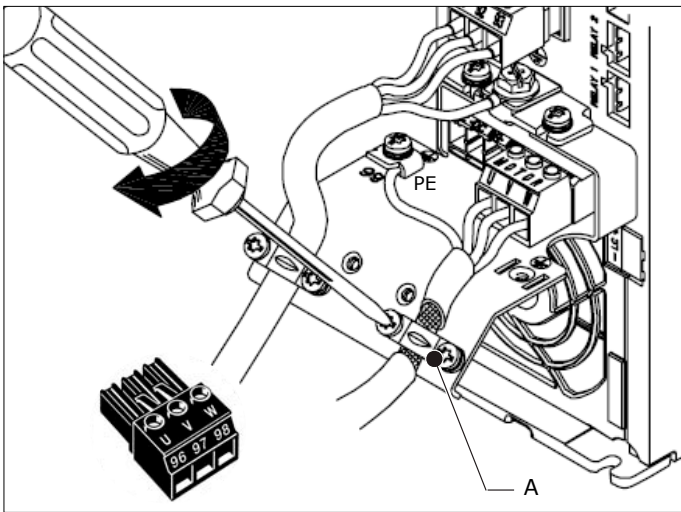

Fig. 4.22 Motor cable to VFD

Fig. 4.23 + Fig. 4.24 (electrical diagram)

Connection of the PTC cable to the VFD

- Connect the PTC cable in accordance with the electrical diagram.
 - A: screwdriver
 - B: wires 13+33

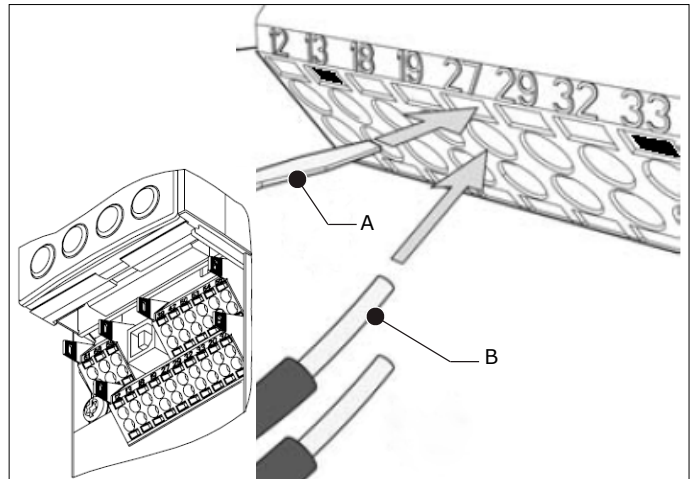

Fig. 4.23 PTC cable to VFD

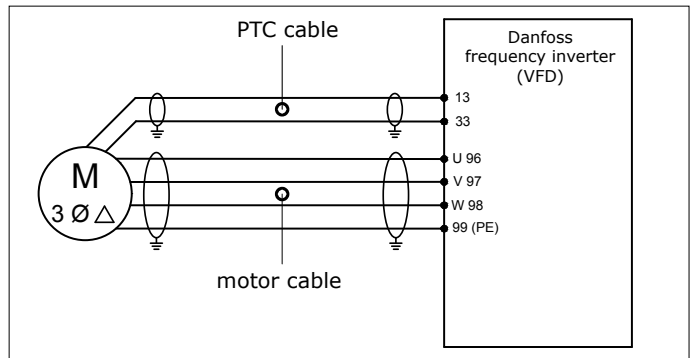

Fig. 4.24 Electrical diagram

- Fasten the cable glands of the motor cable and the PTC cable.

Connection of the motor cable and the PTC cable to the fan motor

Fig. 4.25

- Connect the wires of the motor cable to the connectors U1, V1, W1 (C) and PE (A) in the junction box of the fan.
- Connect the metal plates (supplied in a plastic bag within the junction box) to obtain a "delta" connection. Make sure that the connection is in accordance with the motor plate.
- Connect the wires of the PTC cable (incl. shield to PE) to the PTC connection (B) in the junction box. This connection is *not* phase sensitive.

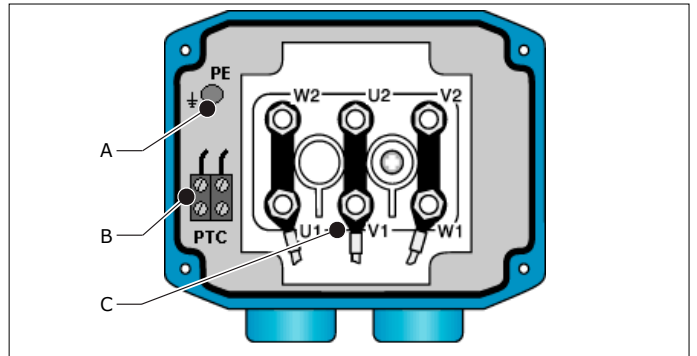

Fig. 4.25 "Delta" connection of the motor cable to the fan motor

4.7.3 Panel → HMI

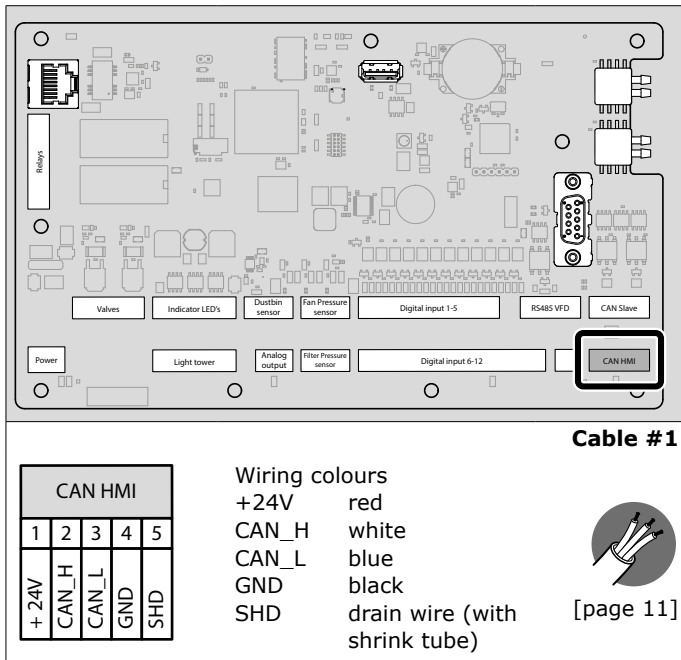

Fig. 4.26 Connection Panel → HMI

4.7.4 Control cable

Besides the compressed air switch, cable #20 connects the compressed air valve of the SCS-Diluter as well.

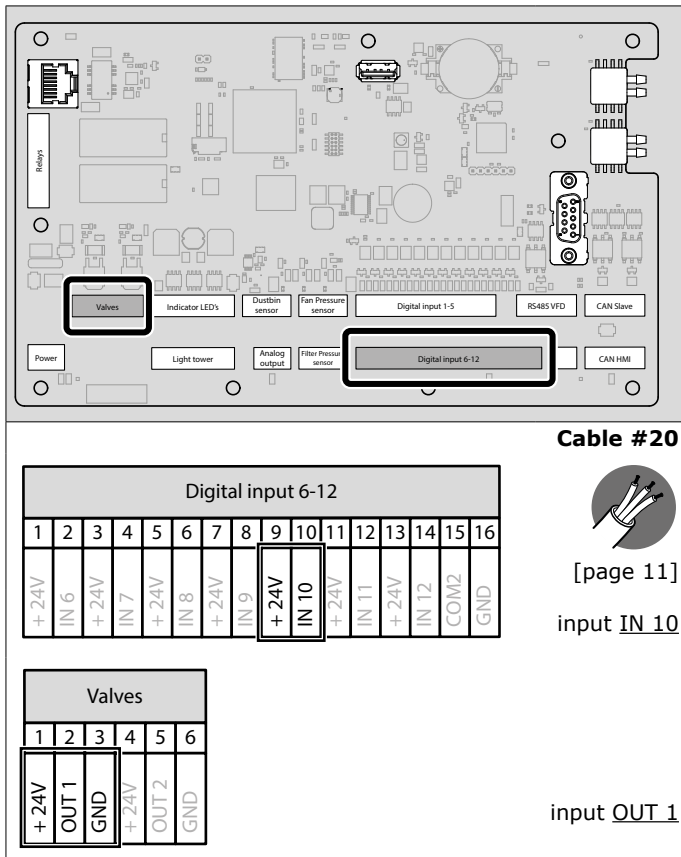
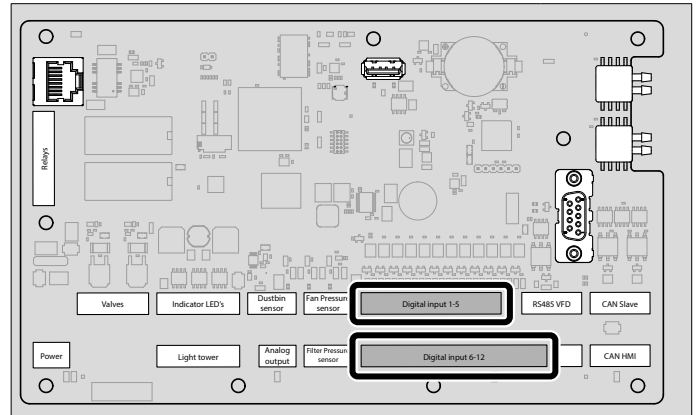

Fig. 4.27 Connection of the control cable

4.7.5 Input signals (options)

If desired, you can connect the ControlPro to a start/stop signal and/or an alarm signal from an external device;

- start/stop signal: cable #6
- alarm signal: cable #7



Digital input 1-5											
1	2	3	4	5	6	7	8	9	10	11	12
+24V	IN 1	+24V	IN 2	+24V	IN 3	+24V	IN 4	+24V	IN 5	COM1	GND

Cable #6



[page 11]

input IN 5

Digital input 6-12															
1	2	3	4	5	6	7	8	9	10	11	12	13	14	15	16
+24V	IN 6	+24V	IN 7	+24V	IN 8	+24V	IN 9	+24V	IN 10	+24V	IN 11	+24V	IN 12	COM2	GND

Cable #7



[page 11]

input IN 11

Fig. 4.28 Connection of external input signals

4.7.6 Output relays (cable #8 and #9) (options)

Both output relays are available for connection to an external device. Possible events to activate the relays are:

- Start/stop fan¹²
- Filter cleaning active
- System mode: Automatic
- Warning active
- Warning signals: no compressed air / dustbin full
- Alarm active
- Alarm signals: no compressed air
- Sliding valve output signal



ATTENTION

- You can choose to connect the cables as NO (normally open) or NC (normally closed).
- Max. connection: 30 VDC / 2,5 A per relay.

- If desired, connect Relay 1 and/or Relay 2 to an external device.



You must select the specific event that you want to activate the relay(s) on the HMI (refer to screen no. 1.4).

12. E.g. a BoosterFan

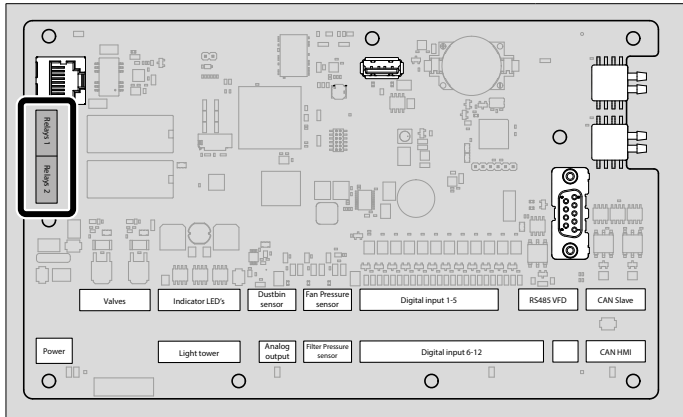

Cable #8

NO 1	1	Relay 1
NC 1	2	
COM 1	3	
	4	



[page 11]

NO 2	5	Relay 2
NC 2	6	
COM 2	7	
	8	



[page 11]

Fig. 4.29 Connection of relay outputs

4.7.7 LightTower (option)

The LightTower contains the same pilot lights as the Panel, including the buzzer.

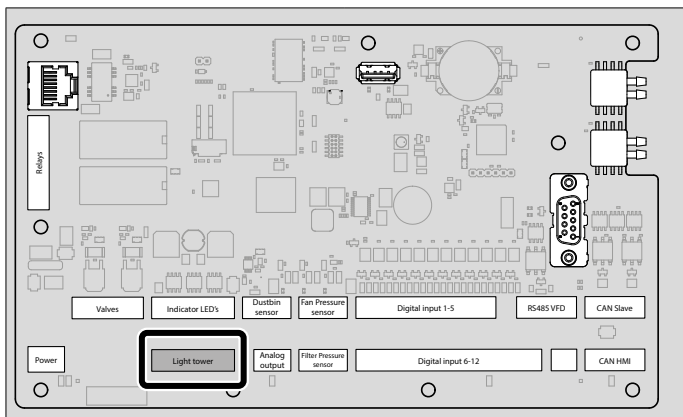

Cable #22

Light tower						
1	2	3	4	5	6	7
+ 24V	PWR	RUN	ALA	WRN	+ 24V	BUZ



[page 11]

Fig. 4.30 Connection of LightTower

- The HMI starts the installation wizard.
- Complete the installation wizard.

Refer to paragraph 5.3 and 5.3.1 for more information about the VFD (frequency inverter) and the PID setpoint.

Select the question mark on the touch screen for extensive explanation on all settings.

5.2 Extraction fan

- Turn the main switch (refer to Fig. 6.1F) to "OFF" and open the Panel.
- Turn the bar that is connected to the main switch to energize the Panel manually.
- Push the START/STOP FAN button (refer to Fig. 6.1F) to start the fan.
- Make sure that the direction of rotation of the motor is correct.

If the direction of rotation of the motor is not correct:

- Invert any two connections (96/97/98) on the VFD to change the motor direction.
- Push the button again to stop the fan.

5.3 VFD (frequency inverter)

The VFD is integrated in the Panel. The fan speed is controlled by the system pressure. To operate the system, you must know or determine the airflow in the duct that is necessary to get the correct throw and air circulation.

The required system pressure must be programmed in the HMI to keep the airflow at a constant level, independently from the (increasing) pressure drop caused by the filter cartridges. This system pressure is called the 'PID setpoint', which arranges the necessary fan speed (Hz) accordingly.

The table below indicates the throw related to the airflow and fan speed¹⁴.

Throw	Airflow/ nozzle	Total airflow	Frequency
20 m (65 ft)	1000 m ³ /h (590 CFM)	6000 m ³ /h (3530 CFM)	30 Hz
40 m (130 ft)	1500 m ³ /h (885 CFM)	9000 m ³ /h (5300 CFM)	50 Hz

For more detailed information, refer to Fig. VIII on page 25. Fig. IX shows the horizontal throw per nozzle.

5.3.1 PID setpoint of the fan pressure

To determine and set the PID setpoint, do the following.

- Go to the Settings menu on the HMI.
- Enter PIN.



Fig. 5.1

- Select menu **PID setpoint of the fan pressure** (or enter **2.2.1** on the numeric keypad).
- Select the button **Start fan**.

13. Indication: the white LED on the Panel is blinking

14. All nozzles 100% open

- Measure the actual airflow with a flowmeter. Best measuring position: approx. 500 mm (20 in.) below the outlet unit of the SCS-Diluter.
- Use the buttons + or – to determine the setpoint to reach the desired airflow. At this setpoint, the frequency must not exceed 45Hz.
- Select **Stop fan** when the desired airflow is reached.
- Select **Finish** to exit the screen. The new values will be saved.

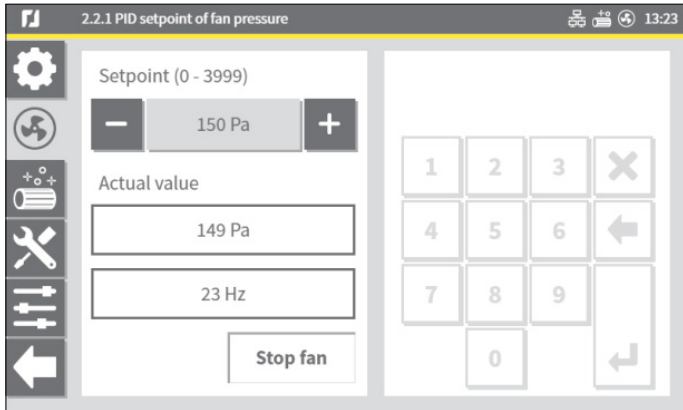

Fig. 5.1 PID setpoint

6 USE



WARNING

During use, always use Personal Protective Equipment (PPE) to avoid injury. This also applies for persons who enter the work area.

6.1 Control equipment

6.1.1 Panel

The control panel contains the following controls and indicators:

Outside

Fig. 6.1 (also refer to Fig. III on page 22)

- A White LED | POWER ON
 - LED off: system is off
 - LED blinking: system is starting up
 - LED on: system is ready
- B Green LED | FAN RUNNING
 - LED off: fan is off
 - LED blinking: fan is ramping down¹⁵
 - LED on: fan is running
- C Yellow LED | WARNING
 - LED off: no problem
 - LED on¹⁶: refer to the HMI for the cause of the warning
- D Red LED | ALARM
 - LED off: no problem
 - LED on¹⁷: refer to the HMI for the cause of the alarm
- E Buzzer | acoustic signal
 - together with the ALARM signal (D)
 - in some cases: together with the WARNING signal (C)
- F Main switch

Inside



ATTENTION

The buttons inside the Panel are for service purposes only. You can control the entire system via the HMI, therefore, the buttons inside the Panel are not necessary for daily use.

G Button | START/STOP FAN

H Button | FILTER CLEANING

- to activate an additional filter cleaning cycle
- to suppress the buzzer (push and hold for 5 seconds)

I Switch 0-1 | SERVICE MODE

- 0: normal mode
- I: to lock the touch screen of the HMI for service purposes

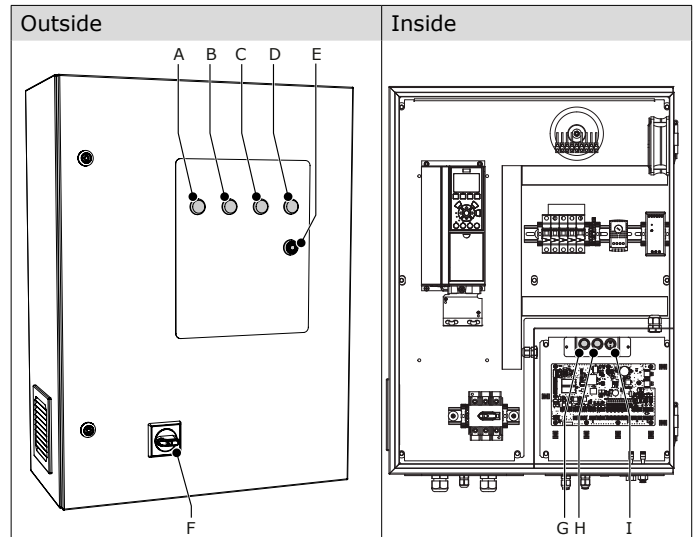

Fig. 6.1 Control panel

6.1.2 HMI



Refer to the online user manual ControlPro for extensive explanation about the HMI:
www.plymovent.com/manuals/controlpro

PLYMOVENT[®]
clean air at work

ControlPro/HMI

- EN User manual
- NL Gebruikershandleiding
- DE Betriebsanleitung
- FR Manuel opérateur
- ES Instrucciones para el uso

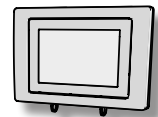

www.plymovent.com/manuals/controlpro

0000112733/0



The online user manual is available in English language only. Short user manuals (PDF format) in other languages are in process. Contact your supplier about the availability of the short user manual in your own language.

15. Ramp down time: 60 seconds

16. The system continues to run

17. The system stops running

6.2 Use

Depending on the specific configuration and system settings on the HMI, you can activate the fan and cleaning system manually or have the entire system run fully automatically.

6.2.1 HMI

The HMI shows the actual system status at all times. To control the entire system via the HMI is self-explanatory.

6.2.2 Panel

Manually activated functions for service purposes only:
Fig. 6.1

- Button START/STOP FAN (G)
- Button FILTER CLEANING (H)^{18 19}

7 MAINTENANCE



7.1 Periodic maintenance

The system has been designed to function without problems for a long time with a minimum of maintenance. In order to guarantee this some simple, regular maintenance and cleaning activities are required which are described in this chapter. If you observe the necessary caution and carry out the maintenance at regular intervals, any problems occurring will be detected and corrected before they lead to a total breakdown.

The indicated maintenance intervals can vary depending on the specific working and ambient conditions. Therefore, we recommend to thoroughly inspect the complete system once every year beside the indicated periodic maintenance. For this purpose contact your supplier.

The maintenance activities in the tables below indicated by [*] can be carried out by the user; other activities are strictly reserved for well trained and authorized service personnel.

7.1.1 SCS-Diluter

	WARNING! Overdue maintenance can cause fire.
	WARNING Always fully disconnect the system from the mains before carrying out maintenance jobs as mentioned below. First read the maintenance regulations at the beginning of this manual.
	WARNING Always disconnect the compressed air supply before carrying out maintenance jobs.

Component	Action	Frequency: every X months		
		X=1	X=3	X=6
Cleaning mechanism	Make sure (by manual operation) that it can turn freely			X
Dustbin	Check level of dust and dirt particles. Empty if necessary (ref. par. 7.2)	X ¹	X ¹	X ¹

¹ Frequency depends on welding process

18. You cannot stop/interrupt the filter cleaning cycle

19. You cannot activate this button during the first 40 running hours of the system and within 40 running hours after filter replacement, to maintain the protective layer of precoat material on the filter cartridges

7.1.2 Control equipment

Panel

	WARNING If applicable, put the Panel in the Service Mode before you do the activities as stated below; refer to Fig. 6.1H.
---	--



Action	Frequency: every X months		
	X=1	X=3	X=12
Clean the outside with a non-aggressive detergent		X [*]	
Make sure that the cable glands are correctly tightened		X	
Check the aluminium inlet grid for pollution. Take it out and clean it with compressed air	X [*]		
Clean the inside with an industrial vacuum cleaner		X [*]	
Make sure that all detachable screw terminal blocks on the PC board are connected		X	

HMI

Action	Frequency: every X months		
	X=1	X=3	X=12
Clean with a non-aggressive detergent		X	
Make sure that the HMI cable is connected		X	
Check for firmware updates; refer to the online user manual			X

7.2 Emptying the dustbin

You must empty the dustbin regularly.

		Personal protective equipment (PPE) Always wear face mask and gloves during emptying the dustbin. Use the supplied dustbin lid during transport.
---	--	--

- Turn off the main switch on the Panel to de-energize the entire system.
- Disconnect the dustbin by loosening the clip.
- Empty the dustbin.
- Place the empty dustbin and fasten the clip.
- Dispose of the contents of the dustbin in accordance with state or local regulations.

7.3 Filter replacement

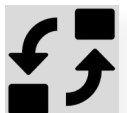

		Personal protective equipment (PPE) Always wear face mask and gloves during filter replacement.
---	--	---

The lifespan of the filter cartridges strongly depends on the welding process, the composition of the welding fumes, the intensity of use and the humidity.

The Panel and/or HMI indicates when filter replacement is necessary.

To replace the filter cartridges, do the following.

- Turn off the main switch on the Panel to de-energize the entire system.
- Loosen the lid (ref. Fig. 4.3A) and remove it.
- Remove the labyrinth spark arrester (upper and lower part; ref. Fig. 4.3B+C).
- Remove the filter cover plate.
- Remove the upper filter cartridge. It can be lifted by the plastic handles.
- Pack the used filter cartridge in the plastic bag in which the new filter is supplied. Seal the bag firmly.
- Remove the intermediate ring.
- Remove the lower filter cartridge and pack it the same way as the upper filter.
- Position the new filter cartridges and mount all parts in reverse order.
- Dispose of the used filter cartridges in accordance with state or local regulations.

	<p>ATTENTION</p> <ul style="list-style-type: none"> • Verify the correct position of the intermediate ring. • Make sure (by manual operation) that the cleaning mechanism can turn freely.
--	---

Finally:

- Follow the instructions on the HMI.

8 TROUBLESHOOTING

If the system does not function (correctly), consult the checklist below to see if you can remedy the error yourself. Should this not be possible, contact your supplier.



	<p>WARNING</p> <p>If applicable, put the Panel in the Service Mode before you do the activities as stated below; refer to Fig. 6.1H.</p>
--	---

8.1 SCS-Diluter

Symptom	Problem	Possible cause	Solution
Dust or fume from outlet nozzles	Pollution of the facility	Filter cartridge(s) damaged or installed incorrectly	Change filter cartridge(s) or install them correctly
Dust from dustbin	System is leaking	Hose clamp(s) installed incorrectly	Install hose clamp(s) correctly
		Bush damaged	Replace the bush
Low airflow or noisy fan	System not working properly	Fan rotation is wrong	Follow the arrow on the fan housing and check if impeller direction matches the indicator. If not, change motor direction by inverting motor phases between frequency inverter and motor (ref. par. 5.2)

Symptom	Problem	Possible cause	Solution
After installation, fan runs at full speed only (50Hz)	The system ignores the PID setpoint	The fan pressure sensor is not correctly installed	Install the fan pressure sensor correctly (ref. par. 4.5.2)
Motor error ("motor failure")	System not working	Fan wheel blocked	Unblock the fan wheel
		The PTC cable is not (correctly) installed	Repair the connection of the PTC cable (ref. par. 4.7.2)
System vibrates at certain frequencies	Noise nuisance	Depending on the length of the duct the unit might have the same frequency as the imposed fan frequency	Contact your supplier
Malfunction of the system	System not working properly	Wrong parameter settings in the frequency inverter	Contact your supplier

8.2 Panel

Symptom	Problem	Possible cause	Solution
Panel			
Yellow WARNING LED is on (with or without buzzer)	<i>Refer to HMI</i>	<i>Refer to HMI; for more info, refer to the online user manual</i>	<i>Refer to HMI</i>
Red ALARM LED is on + buzzer	Fan stops		
	Filter cleaning stops		
USB stick is not recognized	Firmware update not possible	USB-stick does not comply with USB 2.0 standard (too slow)	Use a USB 2.0 or USB 3.0 stick

8.3 HMI

Symptom	Problem	Possible cause	Solution
HMI screen is locked	No control on HMI possible	Panel is in service mode	Put the switch inside the Panel to 0 (refer to Fig. 6.1 I)
		HMI is in lock mode	Enter PIN and unlock the Homescreen
Black screen	HMI does not function	Loose connection	Tighten the HMI cable to the CAN connector (refer to Fig. 4.18B+C)
		Loose or incorrectly connected cable	Connect the HMI cable to the CAN HMI connector (refer to Fig. 4.26)
No installation wizard at start up	Configuration of the system not possible	System configured in an earlier stage	Direct to screen 5.8 to restart the wizard manually If necessary: reset PIN (refer to online user manual)
System does not start (white LED is off)	System does not function	No mains voltage	Connect the mains voltage
		Main switch is off	Turn the main switch to on (refer to Fig. 6.1F)

Symptom	Problem	Possible cause	Solution
White LED remains off	No indication	LED is defective	Replace the LED
Filter and/or fan pressure value = 0 when system is on	No pressure indication	Loose pneumatic hose(s)	Connect the hose(s)
Filter and/or fan pressure value \neq 0 when system is off	Wrong pressure indication	Wrong pressure setting	Do a zero point calibration of the internal sensors (refer to screen 1.2)
Filter pressure value is negative or illogical	Wrong pressure indication	One pneumatic hose is loose	Connect the hose
		Inverted connection of the pneumatic hoses (+ vs. -)	Correct the connection (refer to par. 4.5)
		Wrong type of external pressure sensor configured (PT-1000 vs. PT-2500)	Set the correct type of pressure sensor (refer to screen 1.2)
Malfunction of frequency inverter	Fan pressure value is negative	Wrong connection of the pneumatic hose (+ vs. -)	Correct the connection (refer to par. 4.5)
USB stick is not recognized	Firmware update not possible	USB-stick does not comply with USB 2.0 standard (too slow)	Use a USB 2.0 or USB 3.0 stick

 For more troubleshooting refer to the HMI.

9 SPARE PARTS

The following spare parts are available for the product.



9.1 SCS-Diluter

Refer to exploded view Fig. V on page 23.

9.2 Panel

Refer to exploded view Fig. VI on page 24.

9.3 HMI

Refer to exploded view Fig. VII on page 24.

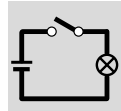

10 ELECTRICAL DIAGRAM

Refer to the separately supplied electrical diagram.



11 DISPOSAL



  **Personal protective equipment (PPE)**
Wear respiratory protection and protective gloves when you dismantle and dispose of the unit.

11.1 Dismantling

To safely dismantle the filter system, obey the safety instructions that follow.

Before dismantling of the system:

- disconnect it from the mains
- disconnect it from the compressed air
- clean the outside

During dismantling of the system:

- make sure that the area is sufficiently ventilated, e.g. by a mobile ventilation unit

After dismantling of the system:

- clean the dismantling area

11.2 Disposal

Dispose of the pollutants and dust, together with the used filter cartridges, in a professional manner in accordance with federal, state or local regulations.

CE DECLARATION

CE Declaration of Conformity for machinery



We, Plymovent Manufacturing B.V., Koraalstraat 9, 1812 RK Alkmaar, the Netherlands, herewith declare, on our own responsibility, that the product:
- SCS-Diluter PRO (incl. Panel and HMI)

which this declaration refers to, is in accordance with the conditions of the following:

Directives:

- Machine Directive 2006/42 EC
- LVD 2014/35 EU | Low Voltage Directive

Harmonised Standards:

- EN-IEC 60204-1:2006 | Safety of machinery - Electrical equipment of machines - Part 1: General requirements
- EN-IEC 61439-1:2011 | Low-voltage switchgear and controlgear assemblies - Part 1: General rules
- EN-IEC 61131-2:2007 | Programmable controllers - Part 2: Equipment requirements and tests
- EN-IEC 61000-6-2:2005 | Electromagnetic compatibility (EMC) - Part 6-2: Generic standards - Immunity for industrial environments
- EN-IEC 61000-6-4:2007 | Electromagnetic compatibility (EMC) - Part 6-4: Generic standards - Emission standard for industrial environments

Alkmaar, Netherlands, 1 March 2019

Jeroen Crezee
Manager R&D

An **installation** is defined as a combination of several finished products or components that are assembled by an installer at a given place. The various parts of the installation are intended to operate together in a particular environment and to perform a specific task. The entire installation must comply with the relevant directives and standards. The assembly instructions given by the manufacturer, as well as the whole method of installation, must be in accordance with good engineering practices within the context of installations, as well as installation rules. Considering the above, the installer will be responsible for completing the installation and issuing the final CE Declaration of Conformity.

Fig. I Dimensions SCS-Diluter

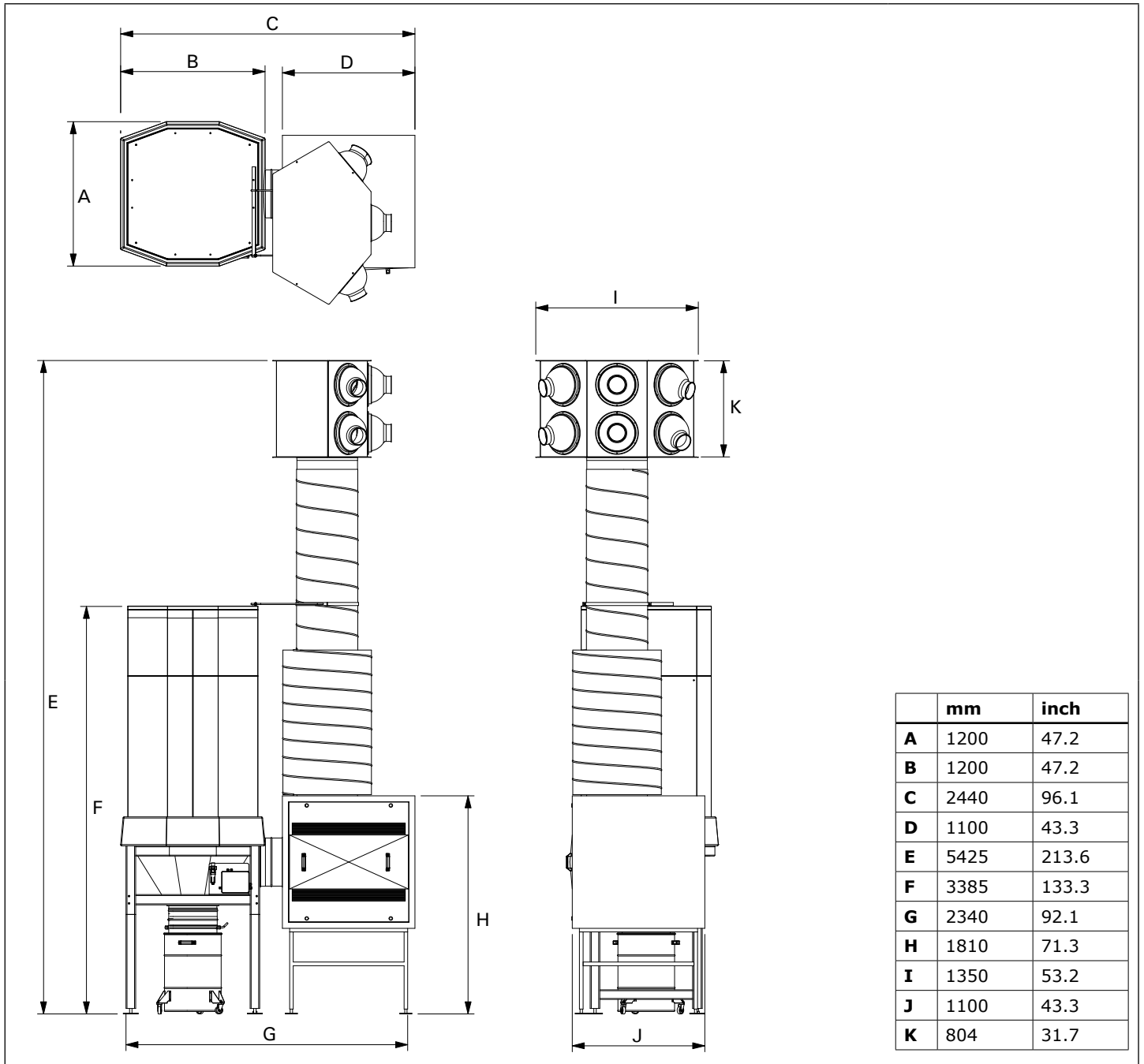

Fig. II Dimensions Panel

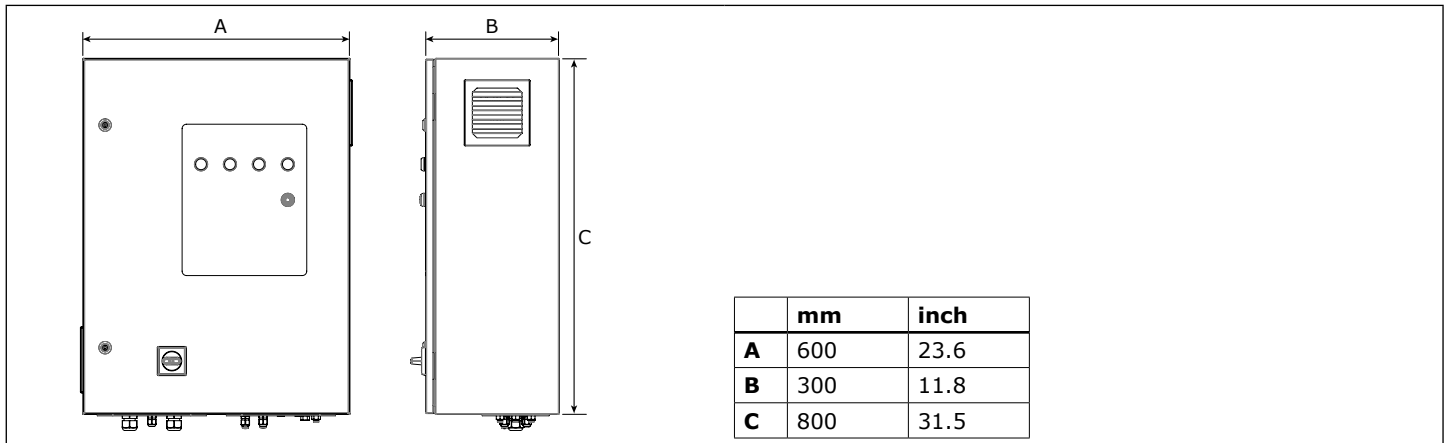

Fig. III Air circulation

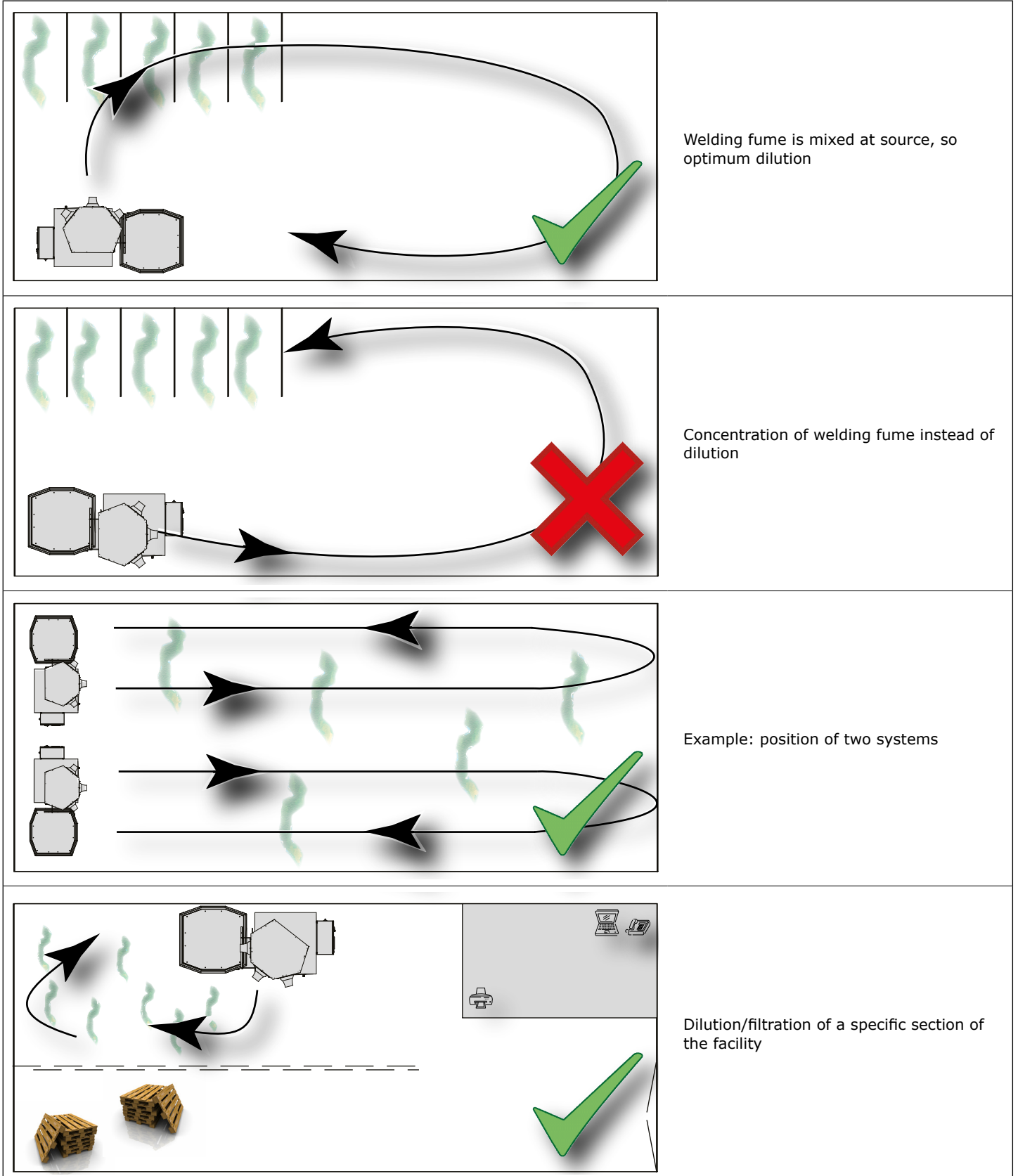
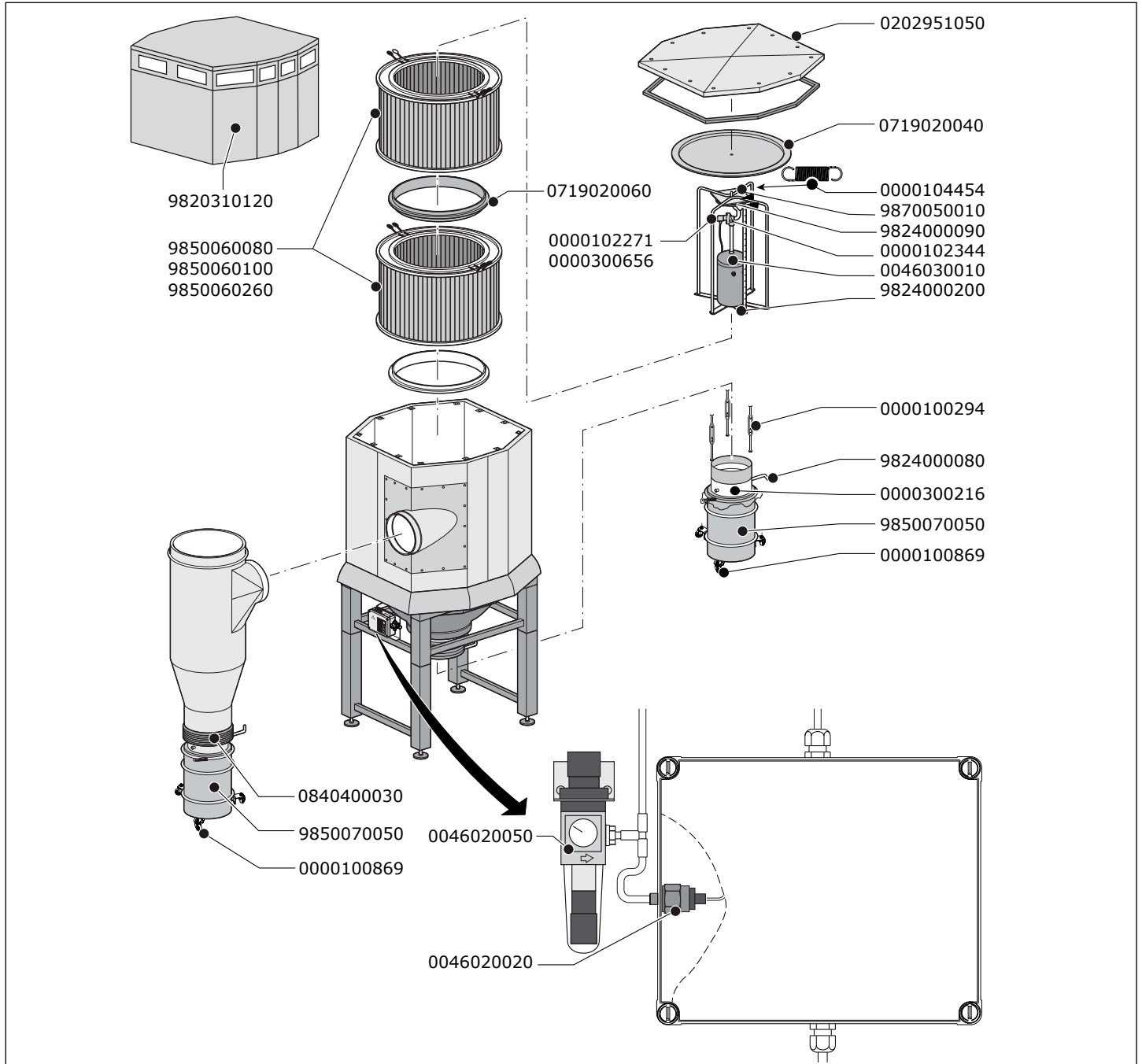

Fig. IV Control panel



Fig. V SCS-Diluter



Art. no.	Description
Filter system SCS-D	
0000100294	Distance holder
0000100869	DB-TROLLEY / Trolley for dustbin DB-100
0000102271	Magnetic valve 3/4 inch 24VAC
0000102344	Membrane + spring of magnetic valve
0000104454	Tension spring
0000300216	Flange for dustbin DB-100
0000300656	Magnetic valve 3/4 inch 24VDC
0046030010	Pressure relief valve 6-10 bar
0202951050	Lid housing
0719020040	Filter cover plate
0719020060	Intermediate ring
0840400030	Bush for dustbin DB-100
9820310120	Air inlet module

Art. no.	Description
9824000080	Closing valve for dustbin DB-100
9824000090	Piston mechanism
9824000200	Revision set bottom cleaning mechanism
9850060080	Filter FCC-150 (2-piece)
9850060260	Filter FCC-150/HE (2-piece)
9850070050	DB-100 / Dustbin 100 litres incl. lid and handles
9870050010	Modification kit cleaning mechanism (top)

Fan SIF-1200	
0000102363	Fan wheel SIF-1200
0321300140	Motor SIF-1200; 400-690V/3ph/50Hz

Junction box	
0046020020	Pressure switch
0046020050	Pressure reducing valve with oil/water separator

Fig. VI Panel

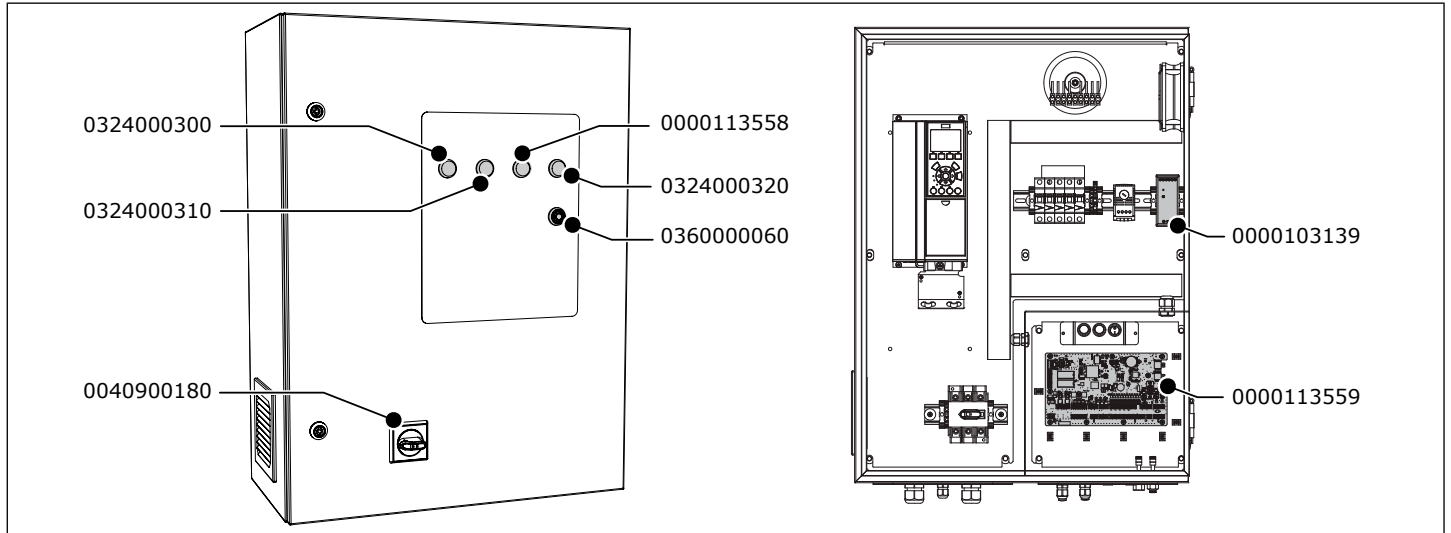

Art. no.	Description
Panel	
0000103139	Switch mode power supply 24V DC 2.5A
0000113558	Indicator light yellow 24V
0000113559	PCB main board ControlPro
0324000300	Indicator light white 24V
0324000310	Indicator light green 24V
0324000320	Indicator light red 24V
0360000060	Buzzer

Fig. VII HMI

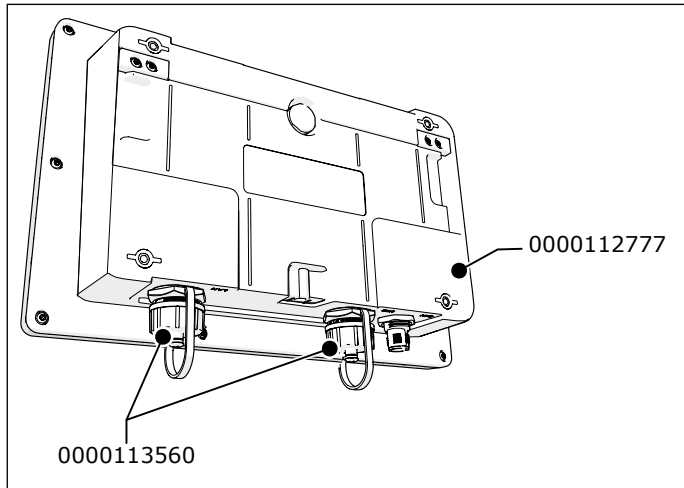

Art. no.	Description
HMI	
0000112777	ControlPro/HMI (complete)
0000113560	Dust cap for ControlPro/HMI

Fig. VIII Velocity, throw and air volume

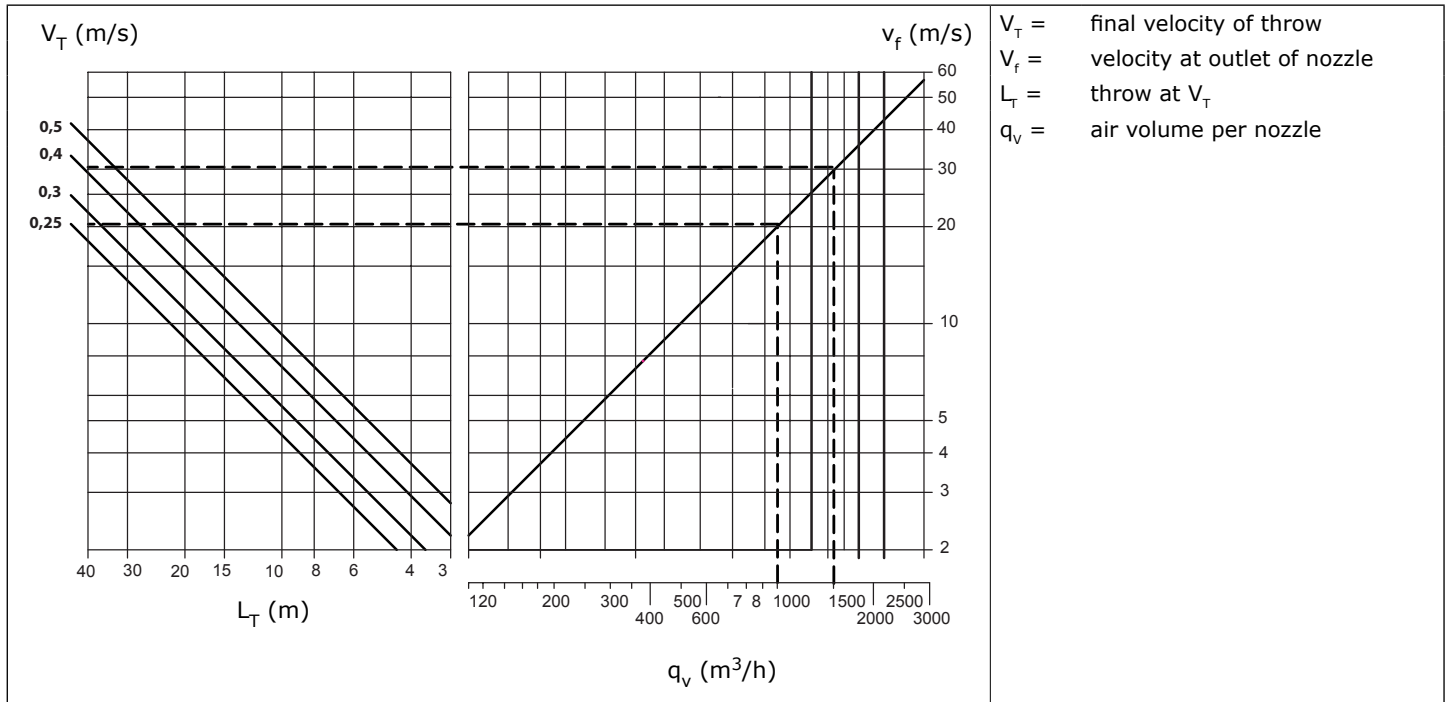

Fig. IX Horizontal throw per nozzle

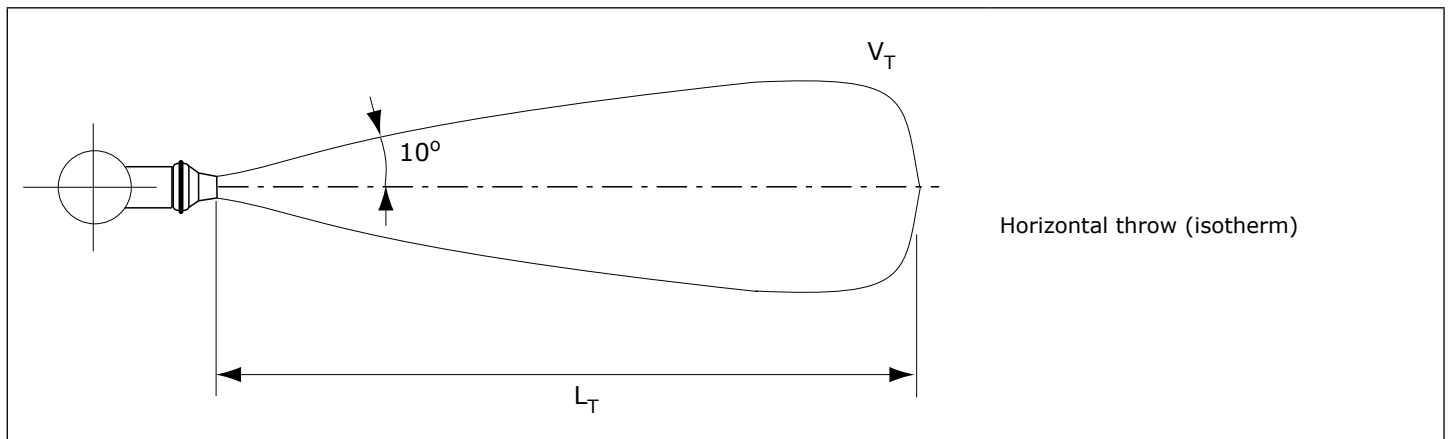

Table I Cable specifications

	Connection	Recommended cable type	Included	Source locally	For use with	Option
#					SCS-Diluter	
1	Panel → HMI (shielded)		✓		✓	
5	Mains cord	H05VV-F 4G4		✓	✓	
6	External start/stop	H05VV-F 2X0.75		✓	✓	✓
7	External alert input			✓	✓	✓
8	Relay output 1			✓	✓	✓
9	Relay output 2			✓	✓	✓
20	Control cable (SCS valve + compressed air switch)	H05VV-F 5G0.75	✓		✓	
22	Light tower	H05VV-F 7X0.5		✓	✓	✓
23	Motor cable	190 CY 4X4 (shielded)	✓			
24	PTC cable	190 CY 2X0.75 (shielded)	✓			

Table II Digital inputs

Input	Input	
	High	Low
IN 5	External signal fan start/stop	
	start	stop
IN 6	Fire alarm	
	normal	alarm
IN 7	Sliding valve 1	
	closed	open
IN 8	Sliding valve 2	
	closed	open
IN 9	Fan alarm	
	alarm	normal
IN 10	Compressed air switch	
	normal	alert
IN 11	External alarm signal	
	normal	alert
IN 12	Dustbin level switch	
	full	not full

