

UK PLYMOTH™

EXTRACTOR CRANE WITH HOSE

Rigid extractor crane with additional telescopic hose tube arm for covering large working areas.

The crane consists of two horizontal parts with metal tubes with a maximum reach of 8 m. The wall and middle hinges provide utmost flexibility. The hose at the end of the crane drops vertically down. The hood is 110° movable in four directions.

The crane is provided with hooks for the suspension of e.g. a wire feeder, cables and tools.



APPLICATIONS

The UK "Plymoth" is intended to be used for the following applications:

- MIG-MAG/GMAW welding
- TIG welding
- FCAW welding
- stick/MMAW welding



SPECIFICATIONS

Physical dimensions and properties	
Diameter:	<ul style="list-style-type: none"> • tubes • hoses • hood opening
	<ul style="list-style-type: none"> • Ø 160 mm (6.3 in.) • Ø 160 mm (6.3 in.) • Ø 300 mm (11.8 in.)
Material of hose	flame-retardant PVC, reinforced with spring steel wire
Colour	black
Weight capacity for suspension of tools etc.:	
<ul style="list-style-type: none"> • inner crane (wall side) • outer crane (hose tube side) 	<ul style="list-style-type: none"> • max. 50 kg (110 lbs.) • max. 10 kg (22 lbs.)
Performance	
Recommended airflow	800-1200 m ³ /h (470-710 cfm)
Ambient and process conditions	
Process temperature:	
<ul style="list-style-type: none"> • min. • nom. • max. 	<ul style="list-style-type: none"> • 5°C (41°F) • 20°C (68°F) • 70°C (158°F)
Max. relative humidity	90%
Outdoor use allowed	no
Storage conditions	<ul style="list-style-type: none"> • 5-45°C (41-113°F) • relative humidity max. 90%
Options and accessories	
SK-100	manual on/off switch for hood mounting
LL-5.5/24-160/SK	manual on/off switch, incl. LED working light
LongHood	long extraction hood
SLE-30	extension hose with nozzle

Product combinations	
FUA-1800 FUA-2100	extraction fan
SLE-30	extension hose
Scope of supply	
Crane and wall bracket Telescopic hose tube (vertical part) Hose and duct set	
Order information	
Number/package	1
Shipping data	
Harmonized Tariff Code	84219990

DIMENSIONS

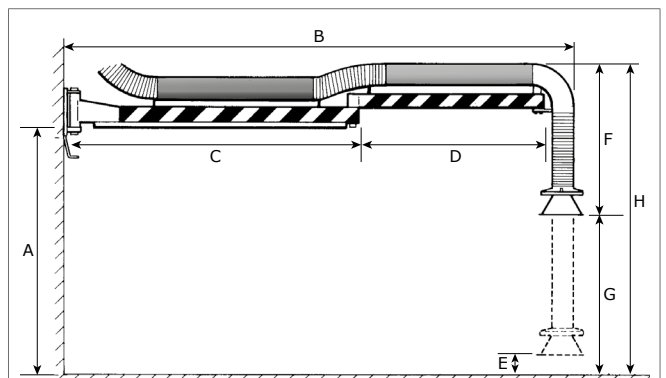

	UK-3.0/160		UK-4.5/160		UK-6.0/160		UK-8.0/160	
	mm	ft.	mm	ft.	mm	ft.	mm	ft.
A	3200	10.5	3200	10.5	3150	10.3	3150	10.3
B	3000	9.8	4550	14.9	6200	20.3	8200	26.9
C	1550	5.1	2550	8.4	3550	11.6	4550	14.9
D	1200	3.9	1750	5.7	2400	7.9	3400	11.2
E	550	1.8	550	1.8	550	1.8	550	1.8
F	1400	4.6	1400	4.6	1400	4.6	1400	4.6
G	1600	5.2	1600	5.2	1600	5.2	1600	5.2
H	3550	11.6	3550	11.6	3550	11.6	3550	11.6

Remaining specifications

	UK-3.0/160		UK-4.5/160		UK-6.0/160		UK-8.0/160	
Physical dimensions and properties								
Working reach (refer to image below):	mm	in.	mm	in.	mm	in.	mm	in.
• inner crane (A)	1550	61	2550	100	3550	140	4550	179
• outer crane (B)	1200	47	1750	69	2400	94	3400	134
Weight (net)	41 kg (90 lbs.)		48 kg (106 lbs.)		73 kg (161 lbs.)		94 kg (207 lbs.)	
Order information								
Art. no.	0000101225		0000101226		0000101227		0000101228	
Shipping data								
Gross weight	49 kg (108 lbs.)		61 kg (134 lbs.)		90 kg (198 lbs.)		118 kg (260 lbs.)	
Packing dimensions								

WORKING REACH

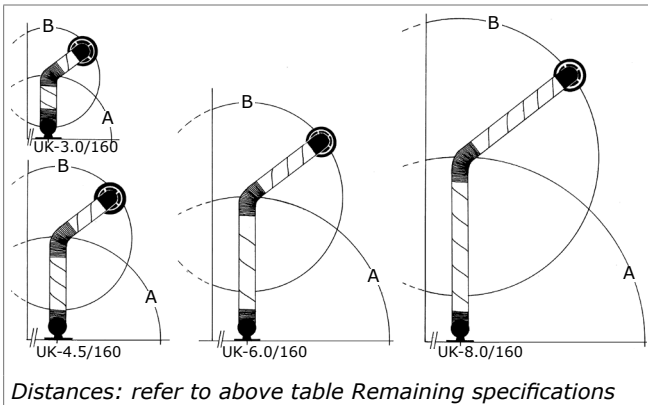

PRESSURE DROP

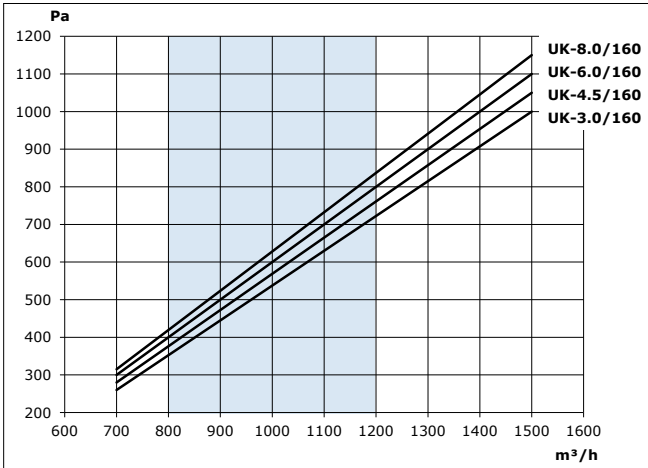

FEATURES & BENEFITS

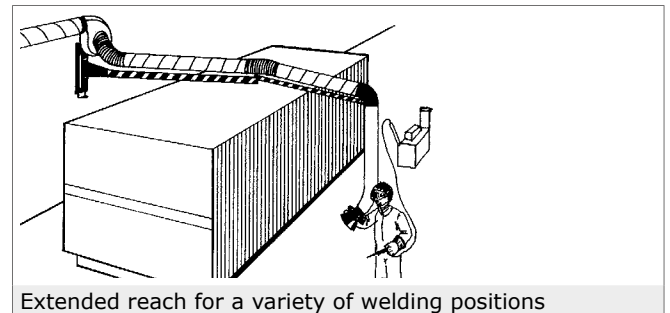
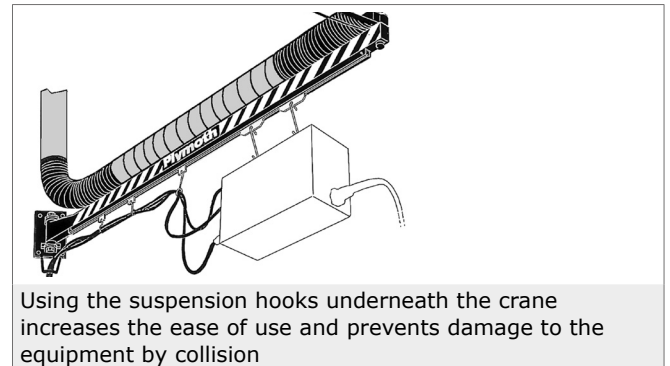
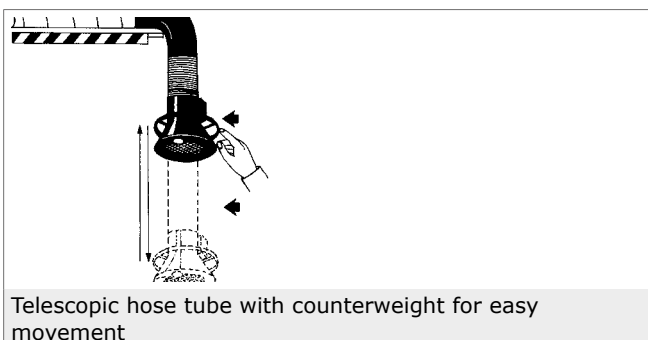

Application restrictions

Do **not** use the product for the following applications or in the following circumstances: polishing applications in combination with grinding, welding or any other application that generate sparks (fibres from polishing or abrasive flap disks are highly flammable and pose a high risk of filter fires when exposed to sparks) | aluminium laser cutting | oil mist | heavy oil mist in welding fume | arc-air gouging | extraction of aggressive fumes and gases (e.g. from acids, from alkaline, from soldering paste containing lithium) | extraction of hot gases (more than 70°C/158°F continuously) | grinding aluminum and magnesium | flame spraying | extraction of cement, saw dust, wood dust etc. | sucking cigarettes, cigars, oiled tissues and other burning particles, objects and acids | explosive environments or explosive substances/gases

Product type

UK "Plymoth"

Article no.

refer to Order information

Product category

extraction arms

Version

091118/B

Always check the latest version on www.plymovent.com