

SER HOSE REEL

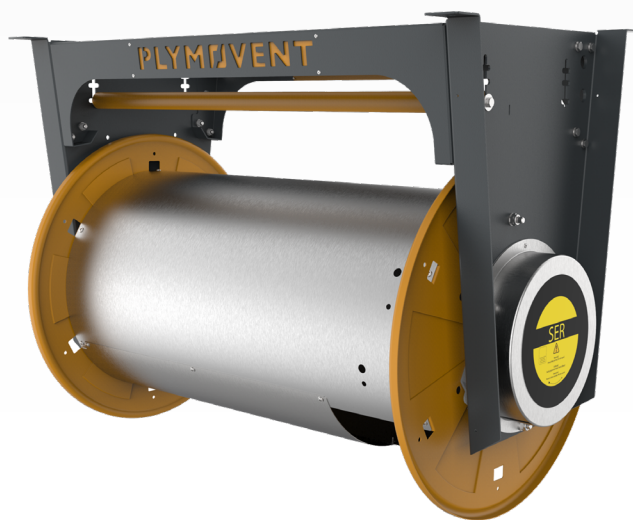

EN Installation manual

EN – ORIGINAL INSTRUCTION

All rights reserved. The information given in this document has been collected for the general convenience of our clients. It has been based on general data pertaining to construction material properties and working methods known to us at the time of issue of the document and is therefore subject at any time to change or amendment and the right to change or amend is hereby expressly reserved. The instructions in this publication only serve as a guideline for installation, use, maintenance and repair of the product mentioned on the cover page of this document. This publication is to be used for the standard model of the product of the type given on the cover page. Thus the manufacturer cannot be held responsible for any damage resulting from the application of this publication to the version actually delivered to you. This publication has been written with great care. However, the manufacturer cannot be held responsible, either for any errors occurring in this publication or for their consequences.

To improve comprehension for people whose first language is not English, we have written parts of this manual in Simplified Technical English (STE). STE is a controlled language originally developed for aerospace industry maintenance manuals. It offers a carefully limited and standardized subset of English, along with specific writing rules.

TABLE OF CONTENTS









ENGLISH	Page
Preface	3
1. Introduction	3
2. Product description	4
3. Safety instructions	4
4. Installation	5
5. Use	7
6. Maintenance	7
7. Troubleshooting	8
8. Spare parts	8
9. Disposal	8
CE declaration	8

PREFACE

Using this manual

Pictograms and symbols

The following pictograms and symbols are used in this manual:

	TIP Suggestions and recommendations to simplify carrying out tasks and actions
	ATTENTION A remark with additional information for the user. A remark brings possible problems to the user's attention.
	CAUTION! Procedures, if not carried out with the necessary caution, could damage the product, the workshop or the environment.
	CAUTION Denotes risk of electric shock.
	WARNING! Fire hazard! Important warning to prevent fire.
	WARNING! Explosion hazard! Important warning to prevent explosions.
	Personal protective equipment (PPE) Instruction to use respiratory protection when you do service, maintenance and repair jobs, as well as during functional testing. We recommend to use a half-face respirator according to DIN EN 141/143, protection class P3.
	Personal protective equipment (PPE) Instruction to use protective gloves when you do service, maintenance and repair jobs.

Text indicators

Listings indicated by "-" (hyphen) concern enumerations. Listings indicated by "•" (bullet point) describe steps to perform.

Service and technical support

For information about specific adjustments, maintenance or repair jobs which are not dealt with in this manual, please contact the supplier of the product. He will always be willing to help you. Make sure you have the following specifications at hand:

- product name
- serial number

You can find these data on the identification plate.

Product indications

Unless specifically stated, the contents of this manual applies to the SER.

1 INTRODUCTION

1.1 Identification of the product

The identification plate contains, among other things, the following data:

- product name
- serial number

1.2 General description

The Spring Exhaust Hose Reel (SER) uses an enclosed spring cassette to recoil the exhaust hose. An operator can pull down the hose to the desired position and pull down again to retract the hose.

SER is recommended for small to medium-sized working areas in which the hose needs to be stored when not in use - limiting potential damage to personnel and vehicles.

1.3 Technical specifications

■ Physical dimensions and properties	
Material <ul style="list-style-type: none">• frame• drum	<ul style="list-style-type: none">• textured powder coat galvanized steel• textured powder coat galvanized steel and galvanized steel
Colour <ul style="list-style-type: none">• frame• drum	<ul style="list-style-type: none">• iron grey (RAL 7011)• yellow (RAL 1004) or basalt grey (RAL 7012)
■ Performance	
Lifting capacity (at hose diameter 150 mm (6 in.))	18 kg (40 lbs) single spring, 34 kg (75 lbs) double spring
■ Ambient conditions	
Operating temperature: <ul style="list-style-type: none">• min.• nom.• max.	<ul style="list-style-type: none">• 0°C (32°F)• 20°C (68°F)• 40°C (104°F)
Max. relative humidity	80%
Outdoor use allowed	no
Storage conditions	<ul style="list-style-type: none">• 0 - 40°C (32 - 68°F)• relative humidity max. 80%
■ Options and accessories	
Automatic damper MSR-24/2 switch for automatic fan start and/or damper control	

2 PRODUCT DESCRIPTION

2.1 Product components

The product consists of the following main components and elements (fig. 2.1):

- A Mounting beams
- B A-frame spring side
- C A-frame air side
- D Drum lid

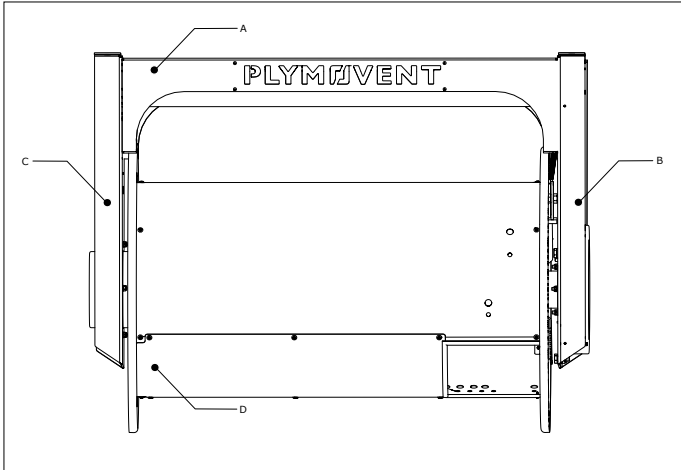

Fig. 2.1 Product components

3 SAFETY INSTRUCTIONS

General

The manufacturer does not accept any liability for damage to the product or personal injury caused by ignoring of the safety instructions in this manual, or by negligence during installation, use, maintenance, and repair of the product mentioned on the cover of this document and any corresponding accessories. Specific working conditions or used accessories may require additional safety instructions. Immediately contact your supplier if you detect a potential danger when using the product.

The user of the product is always fully responsible for observing the local safety instructions and regulations. Observe all applicable safety instructions and regulations.

User manual

- Everyone working on or with the product, must be familiar with the contents of this manual and must strictly observe the instructions therein. The management should instruct the personnel in accordance with the manual and observe all instructions and directions given.
- Do not change the order of the steps to perform.
- Keep the manual with the product.

Users

- The use of this product is exclusively reserved to authorised, trained and qualified users. Temporary personnel and personnel in training can only use the product under supervision and responsibility of skilled engineers.
- Stay alert and keep your attention to your work. Do not use the product when you are under the influence of drugs, alcohol or medicine.
- The product is not to be used by children or persons with reduced physical, sensory or mental capabilities, or lack of experience and knowledge, unless they have been given supervision or instruction.
- Children must be supervised not to play with the product.

Technical specifications

Do not change the specifications given in this manual.

Modifications

Modification of (parts of) the product is not allowed.

Installation

- The installation of this product is exclusively reserved to authorised, trained and qualified engineers.
- The electric connection must be executed in accordance with the local codes and requirements. Ensure compliance with the EMC regulatory arrangements.
- During installation, always use Personal Protective Equipment (PPE) to avoid injury. This also applies to persons who enter the work area during installation.
- Use sufficient climbing gear and safety guards when working on a higher level than 2 metres (local restrictions may apply).
- Do not install the product in front of entrances and exits which must be used for emergency services.
- Mind any gas and water pipes and electric cables.
- Make sure that the workspace is well illuminated.
- Stay alert and keep your attention to your work. Do not install the product when you are under the influence of drugs, alcohol or medicine.
- Air containing particles such as chromium, nickel, beryllium, cadmium, lead etc., should never be recycled. This air must always be brought outside the working area.

Use

- Inspect the product and check it for damage. Verify the functioning of the safety features.
- Check the working environment. Do not allow unauthorised persons to enter the working environment.
- Protect the product against water and humidity.
- Make sure the room is always sufficiently ventilated; this applies especially to confined spaces.
- Make sure that the workshop, in the vicinity of the product, contains sufficient approved fire extinguishers (suitable for fire classes ABC).

Service, maintenance and repairs

- Obey the maintenance intervals given in this manual. Overdue maintenance can lead to high costs for repair and revisions and can render the guarantee null and void.
- Always use Personal Protective Equipment (PPE) to avoid injury. This also applies for persons who enter the work area.
- Make sure the room is sufficiently ventilated.
- Use tools, materials, lubricants and service techniques which have been approved by the manufacturer. Never use worn tools and do not leave any tools in or on the product.
- Use sufficient climbing gear and safety guards when working on a higher level than 2 metres (local restrictions may apply).
- Clean the area afterwards.

4 INSTALLATION

4.1 Tools and requirements

You need the following tools and requirements to install the unit:



- philips screwdriver

4.2 Unpacking

The package contains:



- SER
- U-bolts and nuts
- manual

4.3 Installing the hose

For the SER-650, SER-850, and SER-1050, follow the instructions in chapters 4.3.1 and 4.3.2.

For the SER-1050-200, follow the instructions of section 4.3.3.

	ATTENTION Before rotating the drum, please note the correct rotation direction as specified on the spring cassette. Refer to fig. 4.6.
	TIP Install nozzle and hose stop after winding the hose up onto the drum. This will create maximum ease of install.
	ATTENTION Do not use long tack screws when installing ductwork to the optional HR-AD. Protruding screws could prevent the automatic damper from opening properly

4.3.1 Mounting the hose

For SER-1050-200, skip to chapter 4.3.3.

- Dismantle drum lid by removing the philips screws (fig 2.1, D).
- Rotate the drum to the default position, where the hose stop meets the stop bar. Lock in position.
- Mount the hose connection (C) and the o-ring (B) to the bearing (A) (fig. 4.2).
- Mount hose to the duct adapter using hose clamp (D) together with the hose support bracket (fig. 4.2).
- Bend hose into a natural soft curve and fasten it using clamp (E) (fig. 4.3).
- Re-mount the drum lid.
- Mount the edge protection (F) at the opening of the drum where the hose protrudes (fig. 4.3).
- Wrap remaining hose around the drum.

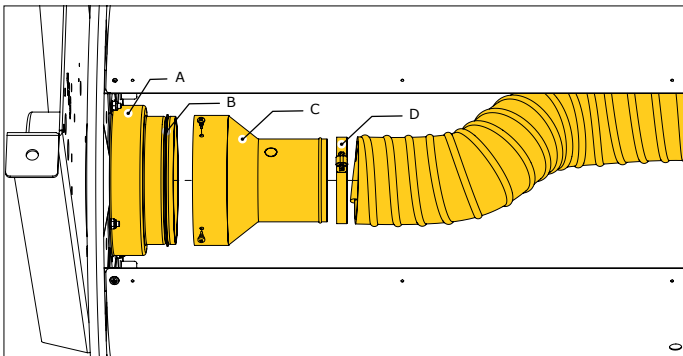

Fig. 4.2 Mounting the hose

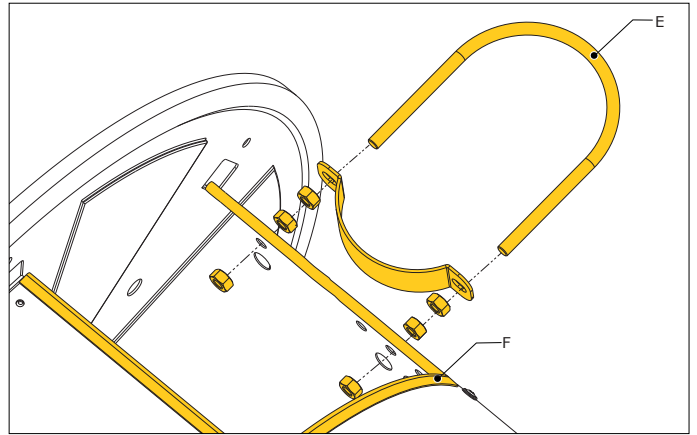

Fig. 4.3 Straining the hose

4.3.2 Adjusting hose stop bar

For SER-1050-200, skip to chapter 4.3.3.

The height of the hose stop bar in the frame can be adjusted to accommodate the different hose diameters. For a system with a 75 mm (3 in.) hose, place the bar at the bottom position, with a 100 mm (4 in.) at the middle position, with a 125 mm (5 in.) at the top position and for a system with a 150 mm (6 in.) hose remove the bar completely. Refer to fig. 4.4 below.

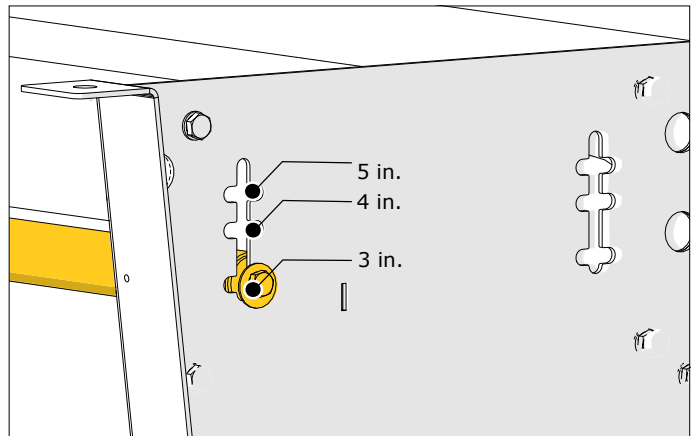

Fig. 4.4 Adjusting the height of the hose stop bar

4.3.3 Mounting the hose (200 series)

For SER-650, -850, and -1050, refer to chapter 4.3.1 and 4.3.2.

- Dismantle drum lid by removing the philips screws (fig 2.1, D).
- Bend hose into a natural soft curve and fasten it to the inside duct (B) by using a hose clamp (A) (fig. 4.5).

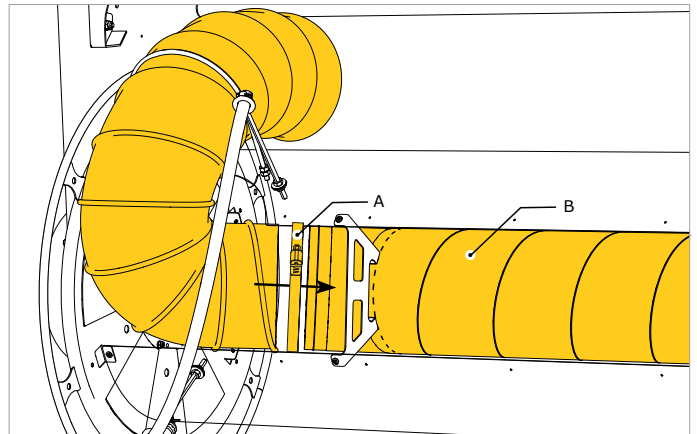

Fig. 4.5 Mounting the hose

4.4 Mounting on wall or ceiling

ATTENTION
Please consult the table heights and dimensions in paragraph 4.6 before to determine the mounting height of the hose reel before installation.

4.4.1 Wall mounting

The package contains no mounting hardware for mounting the frame, since the required mounting hardware depends on the wall type. The hose reel can be mounted on e.g.:

- a thin brick or concrete wall (min. thickness 120 mm (4 in.), using four threaded rods M12;
- a thick brick or concrete wall, using four cotter bolts M12x120x60;
- a steel profile (e.g. H-profile), using four threaded rods M12. For this purpose two square tubes (30x30x3 mm (1.2x1.2x0.1 in.)) need to be mounted to prevent bending.

Refer to fig. 4.6 below.

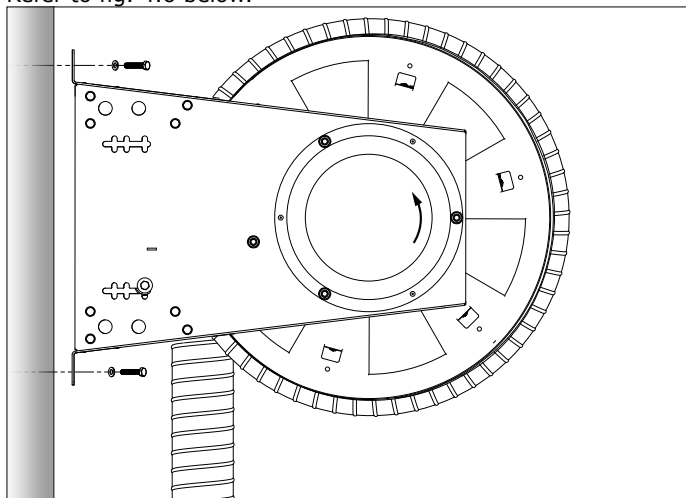

Fig. 4.6 SER mounting on wall

4.4.2 Ceiling mounting

The package contains no mounting hardware for mounting the frame, since the required mounting hardware depends on the ceiling type.

Refer to fig. 4.7 below.

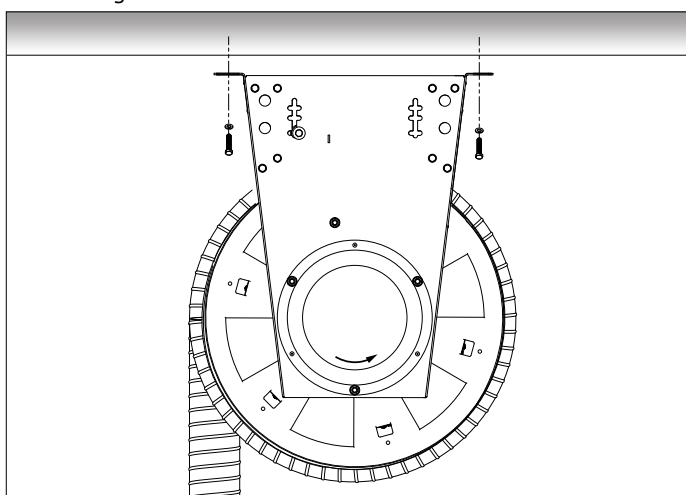

Fig. 4.7 SER mounting on ceiling

4.5 Heights and dimensions

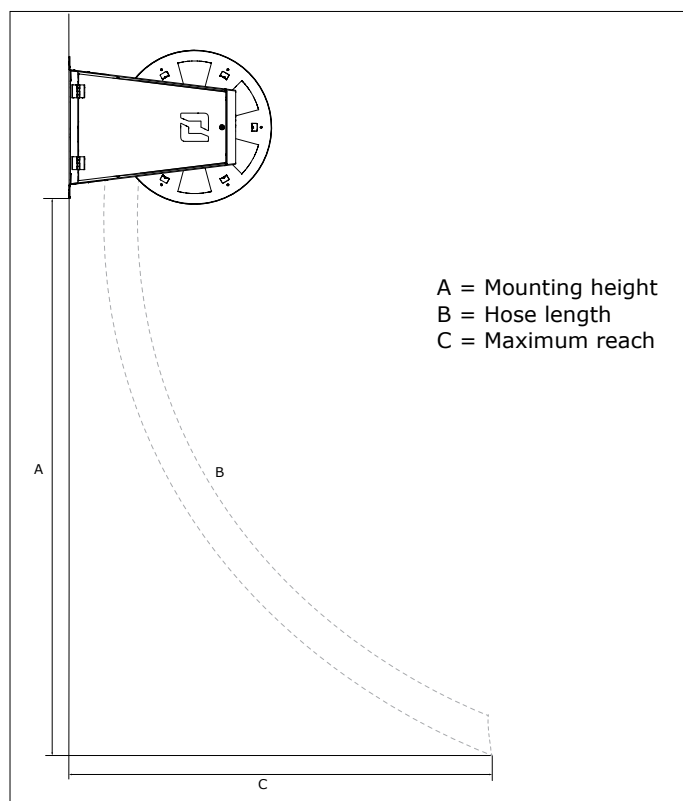

Fig. 4.8 Heights and dimensions chart

Hose length	Mounting height	Maximum reach
7,5 m (25 ft)	3 m (9.8 ft)	6,2 m (20.4 ft)
	3,5 m (11.5 ft)	5,9 m (19.4 ft)
	4 m (13.1 ft)	5,5 m (18 ft)
	4,5 m (15 ft)	5,2 m (17.1 ft)
	5 m (16.4 ft)	4,7 m (15.5 ft)
10 m (33 ft)	3,5 m (11.5 ft)	8,5 m (28 ft)
	4 m (13.1 ft)	8,3 m (27.3 ft)
	4,5 m (15 ft)	8 m (26.3 ft)
	5 m (16.4 ft)	7,7 m (25.3 ft)
	5,5 m (18 ft)	7,4 m (24.3 ft)
12,5 m (41 ft)	5 m (16.4 ft)	10,6 m (35 ft)
	5,5 m (18 ft)	10,3 m (34 ft)
	6 m (19.7 ft)	10 m (33 ft)
	6,5 m (21.4 ft)	9,7 m (32 ft)
	7 m (23 ft)	9,4 m (31 ft)

4.5.1 Dimensions

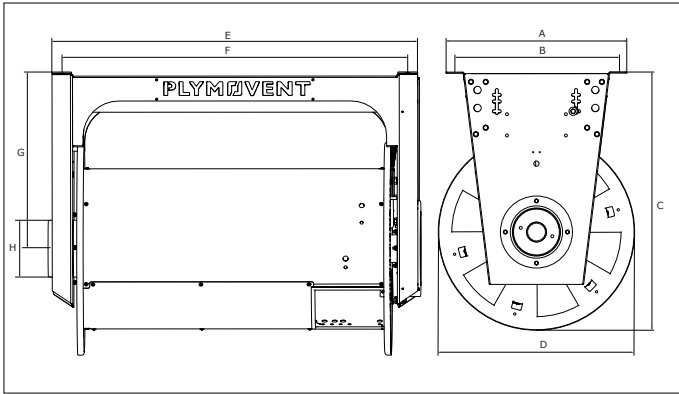

Fig. 4.9 SER dimensions

	SER-450	SER-650
A	552 mm (21.7 in.)	552 mm (21.7 in.)
B	500 mm (19.7 in.)	500 mm (19.7 in.)
C	789 mm (31.1 in.)	789 mm (31.1 in.)
D	600 mm (23.6 in.)	600 mm (23.6 in.)
E	628 mm (24.7 in.)	828 mm (32.6 in.)
F	573 mm (22.6 in.)	773 mm (30.4 in.)
G	489 mm (19.3 in.)	489 mm (19.3 in.)
H	∅ 160 mm (6.3 in.)	∅ 160 mm (6.3 in.)

	SER-850	SER-1050	SER-1050-200
A	552 mm (21.7 in.)	552 mm (21.7 in.)	552 mm (21.7 in.)
B	500 mm (19.7 in.)	500 mm (19.7 in.)	500 mm (19.7 in.)
C	789 mm (31.1 in.)	789 mm (31.1 in.)	789 mm (31.1 in.)
D	600 mm (23.6 in.)	600 mm (23.6 in.)	600 mm (23.6 in.)
E	1028 mm (40.5 in.)	1228 mm (48.3 in.)	1228 mm (48.3 in.)
F	973 mm (38.3 in.)	1173 mm (46.2 in.)	1173 mm (46.2 in.)
G	489 mm (19.3 in.)	489 mm (19.3 in.)	489 mm (19.3 in.)
H	∅ 160 mm (6.3 in.)	∅ 160 mm (6.3 in.)	∅ 200 mm (8 in.)

4.6 Options and accessories

4.6.1 Micro switch MSR-24/2

For installation of the MSR-24/2, refer to MSR-24/2 manual.

4.6.2 Automatic damper

When a SER with automatic damper has been ordered the damper will be preinstalled on the unit.

5 USE

The SER hose reel includes either one or two heavy-duty springs that are factory installed to the outside of the reel assembly. An operator pulls the hose down to a convenient position, which locks the hose in place. When the SER is no longer needed, the operator recoils the hose by pulling down on the hose, allowing the hose to recoil in a controlled manner.

6 MAINTENANCE

6.1 Periodic maintenance



The product has been designed to function without problems for a long time. In order to guarantee this, some simple, regular maintenance activities are required which are described in this chapter.

The maintenance activities in the table below can be carried out by the user.

Component	Action	Frequency: every X months	
		X=6	X=12
Hose	Check if the hose is securely fastened inside the drum		X
	Check the hose for wear and tear		X

6.2 Replacing the hose

Replace the hose when damaged beyond repair.

- Rotate the drum to the default position, where the hose stop meets the stop bar. Lock in position.
- Remove the old hose.
- Follow the installation instructions in chapter 4 to install the new hose.

6.3 Replacing the bearings

Only for SER-650, -850, and -1050.

Refer to fig. 6.3 and 6.4 below.

- Unwind the hose all the way down.
- Remove edge trim (C), drum lid (A) and clamp (B).
- Remove the duct adapter (E), the hose (F) and the bearings (D).
- Mount new bearings to the reel and fasten.
- Attach duct adapter and hose, bend it into a natural soft curve and fasten it using clamp (B).
- Re-mount the drum lid (A).
- Re-mount the edge protection (C) at the opening of the drum where the hose protrudes.
- The reel is now ready for use.

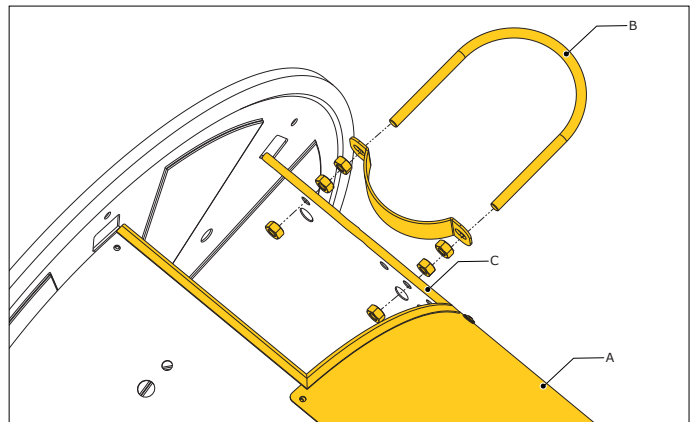

Fig. 6.10 Removing clamp, edge trim and drum

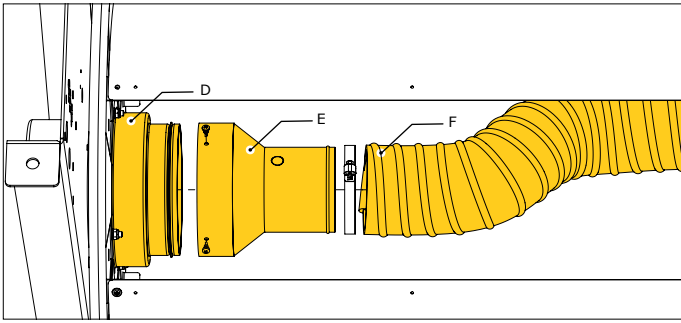

Fig. 6.11 Replacing the bearings

6.4 Replacing the spring cassette

For instructions on replacing the spring cassette, refer to its instruction sheet.

7 TROUBLESHOOTING

If the system does not function (correctly), consult the checklist below to see if you can remedy the error yourself. Should this not be possible, contact your supplier.



Problem	Possible cause	Solution
There is no air flow	Fan is running, but obstacles may block the airflow	Inspect airflow path for obstacles
Reduced airflow	Fan runs in the wrong direction (3 ph only)	Switch two out of three wires (any two will do)
	Hose reel is not wound down completely	Make sure the hose reel is completely wound down
	Hose might be disconnected inside the drum	Reconnect the hose
The hose does not move up	Too much weight on the hose reel	Adjust the spring tension so the hose will just roll up automatically. (do not exceed the max hose and nozzle weight of 18 kg (40 lbs) for single spring and 34 kg (75 lbs) for double spring)

8 SPARE PARTS

Refer to fig. 8.1 and 8.2 below.

Position	Article number	Description
1	0000116955	Edge cover
2	0000112492	Spring cassette
3	0000116975	Bearing hose and drive side 160 mm
-	0000116977	Ratchet lock and spring

For more spare parts, please consult the spare part price list.

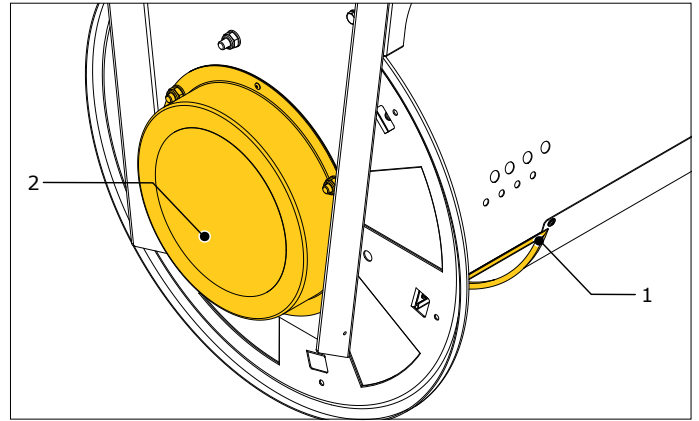

Fig. 8.1 Spare parts part 1

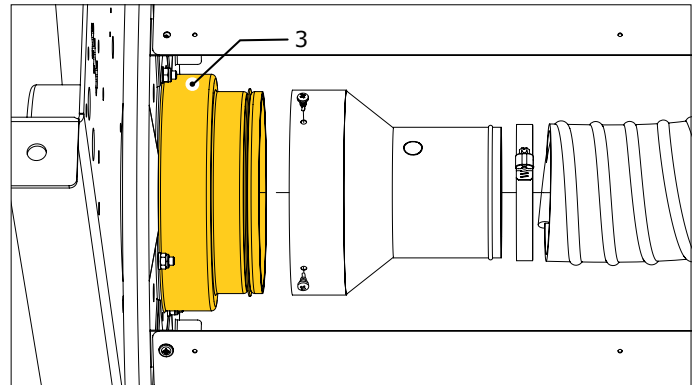

Fig. 8.2 Spare parts part 2

9 DISPOSAL

After life of the product, dispose it of in accordance with federal, state or local regulations.

DECLARATIONS

CE & UKCA declaration of conformity for machinery

We, Plymovent, Koraalstraat 9, 1812 RK Alkmaar, the Netherlands, herewith declare, on our own responsibility, that the product(s):

- Spring operated hose reel (SER)

which this declaration refers to, is/are in accordance with the conditions of the following Directive:

- CE Machine Directive 2006/42/EC
- UKCA Supply of Machinery (Safety) Regulations 2008

and is/are in conformity with the following harmonized standard(s) and/or other such normative documents + amendments, if any:

EN 12100:2010
EN 61000-6-1:2007

Alkmaar, the Netherlands, December 19th, 2022

Kees Janssen
Product Manager EE

NOTES

NOTES

